

**Product Advantages:**

- All stainless steel construction with radiuses inside for easy cleaning.
- The offset ventilation at the top allows for positioning up against a wall in optimum safety. Thermal insulation of muffle by glass wool. Removable protective plate for fan and heating element.
- Thermal and electric protection (IP 25) of the different internal components.
- Fan and heating cut out on opening of door. Time ranges from 0 to 90 minutes.
- Automatic start of reheating after selection via the timer knob.
- Buzzer at end of reheating cycle.
- Multi-program oven: Possibility of setting 2 to 3 different reheating times with buzzer between each program.
- Oven automatically switches to holding mode at the end of the reheating cycle(s).
- Stop of timer countdown on opening of door. Condensate drip tray, 40 mm deep on support GN1/1 (ref. 507 655).

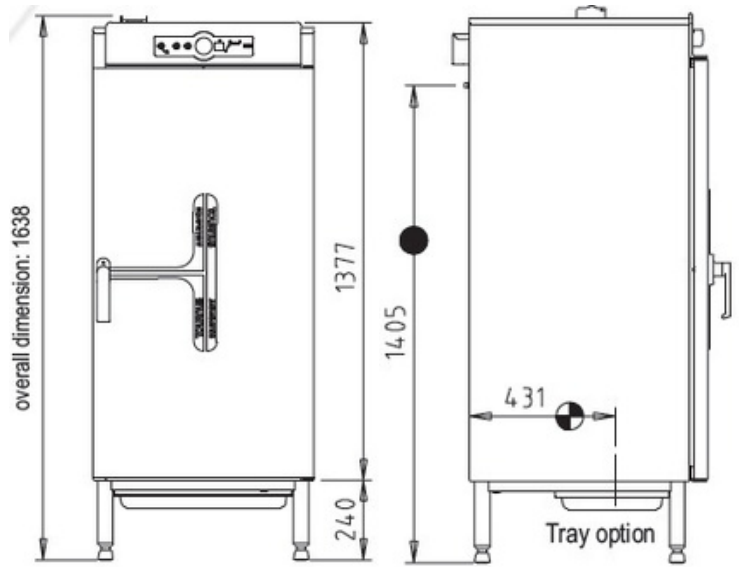

TOURNAUS EQUIPEMENT



**Technical Data:**

Reference	507 640
Overall dim. (L x D x H)	665 x 815 x 1638 mm
Connected load (kW)	13.25
Voltage (V)	415 3 phase AC
Recommended fuses (A)	3 x 20
Net weight (kg)	107
Number of portions	300 portions

