

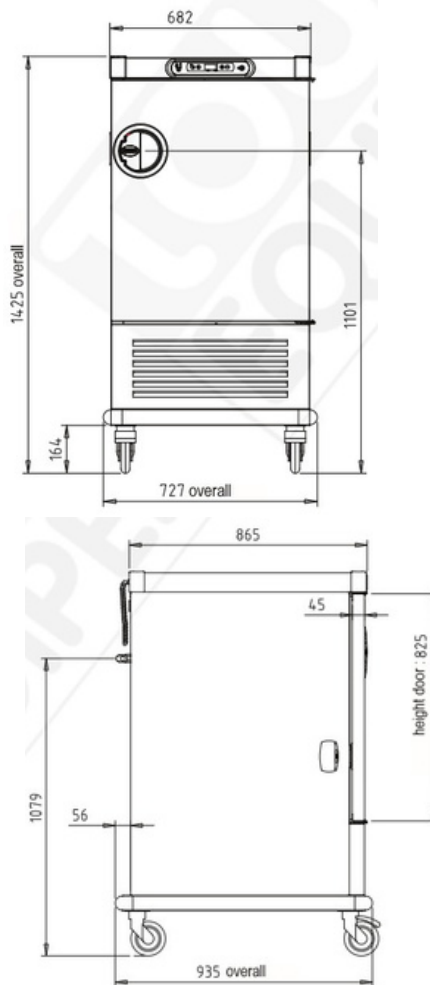

Product Advantages:

- Made of food quality stainless steel.
- Insulation of walls 45 mm rock wool + 20 mm melamine foam.
- Insulation of door 45 mm thick with rock wool. Inside entirely radiused, with press-drawn sliders and base.
- Door with removable seal opens 270°.
- Carrying handles on sides and back.
- Wheels Ø 125 mm with polyamide cover, 2 with brakes.
- Circumferential bumper.
- Fan-assisted refrigeration controlled by an electronic thermostat with digital readout and the following functions:
- Adjustment range of set value from 0 to 10 °C.
- Possibility of deferred start.
- Dysfunction alarms for cabinet and refrigerated unit maintenance.

Spiral power cable 3G1.5 with moulded plug + plug support.



Technical Data:

Reference	507 295
Loading	20 GN 1/1 ht. 65 mm 10 GN 2/1 ht. 65 mm
Space between sliders	71 mm
Overall dim. (L x D x H)	727 x 935 x 1425 mm
Internal dim (L x D x H)	535 x 710 x 755 mm
Weight when empty	122 kg
Max	240 kg
Loading	240 1 phase AC
Voltage (V)	225
Power input (W)	330
Power refrigerating (W)	2.2 A
Max current	25
Protection Index	R134A - 200 gr.
Type of refrigerant	NF EN 60335-1
Standards	NF EN 60335-2-89

