

Roll-in blast chiller



Models : CT40150PRORE & CT40200PRORE

400V 3N 50Hz





CAPACITY

CT40150PRORE

 **150 kg**  **135 kg**
+90°C → **+3°C** **+90°C** → **-18°C** TROLLEY/S **1 - 2**

CT40200PRORE

 **200 kg**  **175 kg**
+90°C → **+3°C** **+90°C** → **-18°C**
1 Trolley
600x1000 mm
GN 2/1
2 Trolleys
600x400 mm

FEATURES

- Touch 7" control panel
- Functions: **blast chilling**, **shock freezing**, manual cycle
- Storable recipes
- USB Drive included
- Stainless steel AISI 304 construction
- 70 mm panel thickness (HFC free)
- Core probe
- Hot gas defrosting
- HACCP data report
- Remote condensing unit
- Floor and ramp included
- Ozone Sanitisation
- Maximum Ambient Temperature 32 Degrees C

OPTIONAL

- Version without condensing unit
- Water cooled condensing unit
- Sound-absorbing condensing unit case
- Second core probe
- Pass-through door (tunnel)
- Tropical rated remote condenser

TECHNICAL FEATURES

	CT40150PRORE	CT40200PRORE
Product Code		
Power Supply (no lead or plug supplied)	400V/3N/50HZ	400V/3N/50HZ
Outside width	1580 mm	1580 mm
Outside height	2350 mm	2350 mm
Outside depth	1390 mm	1390 mm
Maximum Trolley Dimensions	940W x 1090D x 2000H mm	940W x 1090D x 2000H mm
Cable size	5 x 4,0 mm ²	5 x 4,0 mm ²
Absorbed power	7400 W - 22A	9600 W - 27A
Shipment data (WxDxH - kg)	250 x 165 x 144cm-580 kg	250 x 165 x 144cm-580 kg
CONDENSING UNIT FEATURES - 10 mt max distance		
Voltage (no lead or plug supplied)	400V/3N/50HZ	400V/3N/50HZ
Refrigeration power (-20°C / + 40°C)	10970W - 5,5HP	14270W - 7,5HP
Defrost	Hot gas	Hot gas
Discharge pipe diameter mm of included kit	12	12
Suction pipe diameter of included kit	28	28
Hot gas pipe diameter mm of included kit	10	10
Gas charge - type	R452A (GWP2141)/ R404	R452A (GWP2141)/ R404
Shipment data (WxDxH - kg)	95 x 160 x 85cm-310 Kg	96 x 158 x 85mm-320 Kg
Floor Height	70mm	70mm

our technology,
your taste

Roll-in blast chiller

Models : CT40150PRORE & CT40200PRORE

400V 3N 50Hz

DIMENSIONS

FRONT VIEW

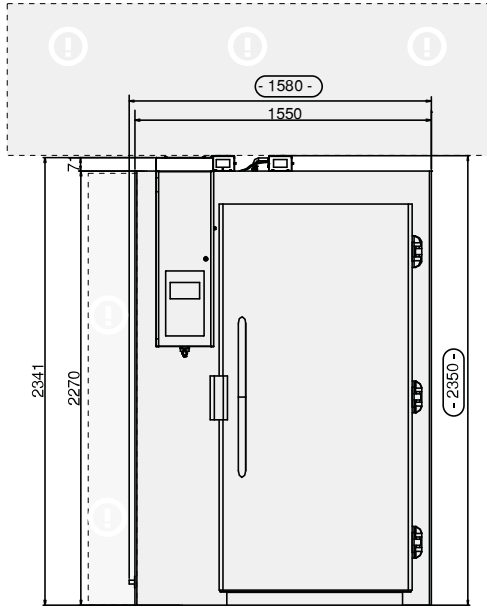

Useful area for water drain connection

LATERAL VIEW

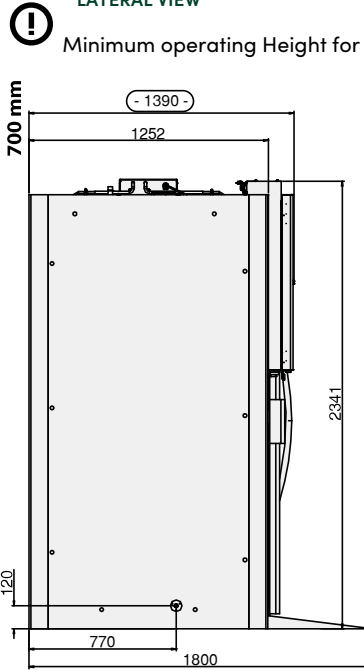

Minimum operating Height for installation

TOP VIEW

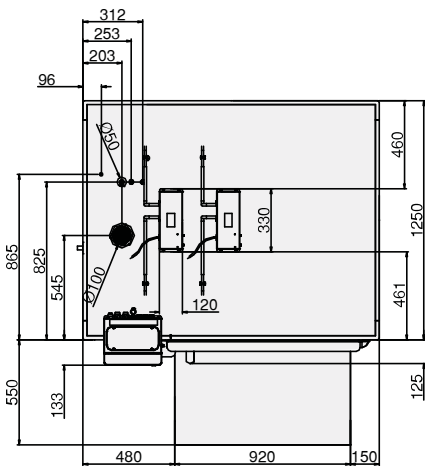
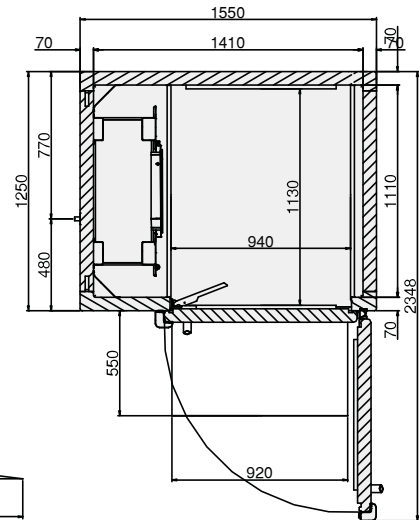

Predisposed WI-FI connection
Connessione WI-FI predisposta

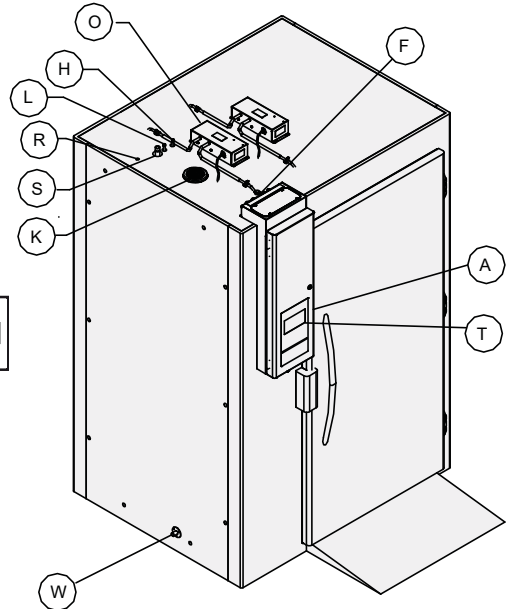

Second Door Optional

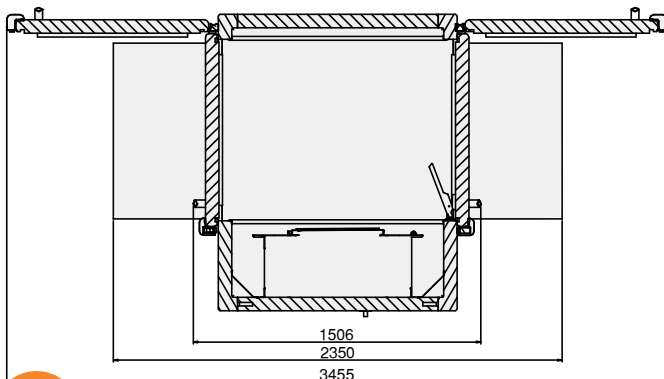

- O Ozone Box
- K Compensation valve
- R Cables outlet
- H Hot gas line
- S Suction line
- L Liquid line
- W Water discharge Ø 20 mm
- T Touch Panel 7"
- A Electric box
- F WiFi Connection

CONDENSING UNIT

5.5 HP

10 mt Kit remote distance
INCLUDED

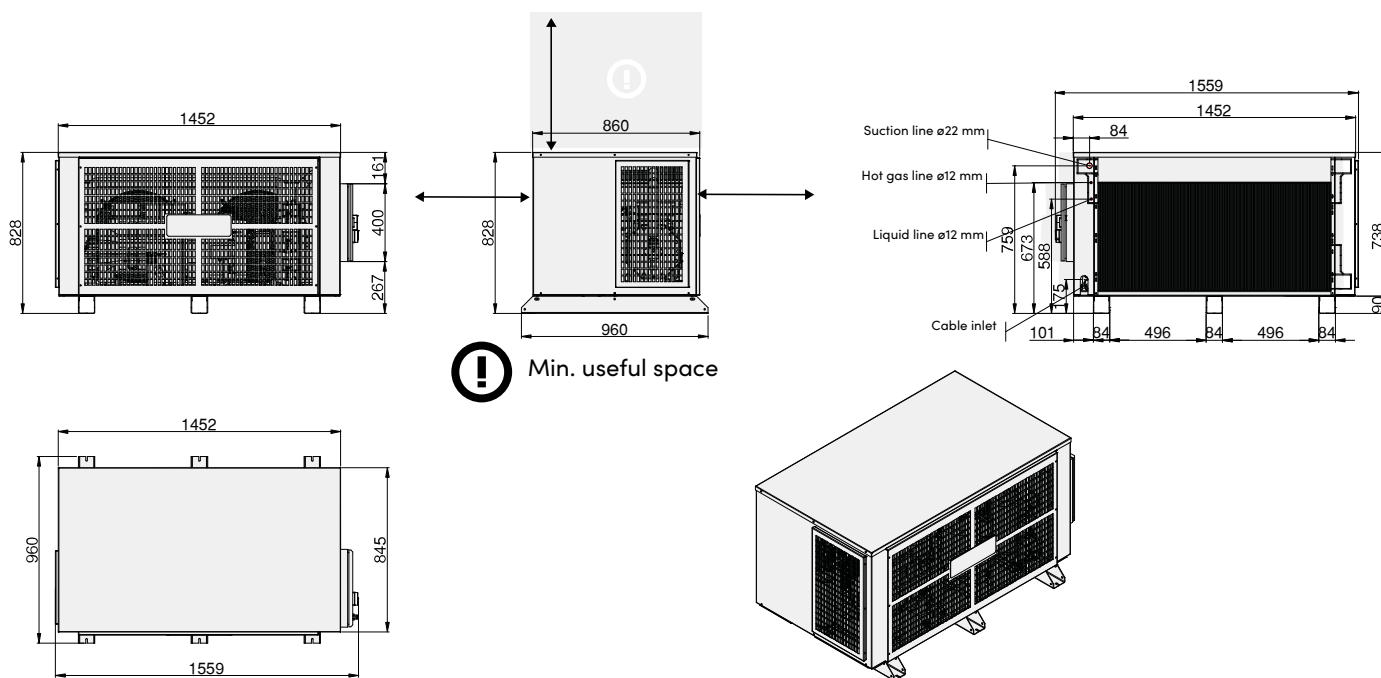

7.5 HP

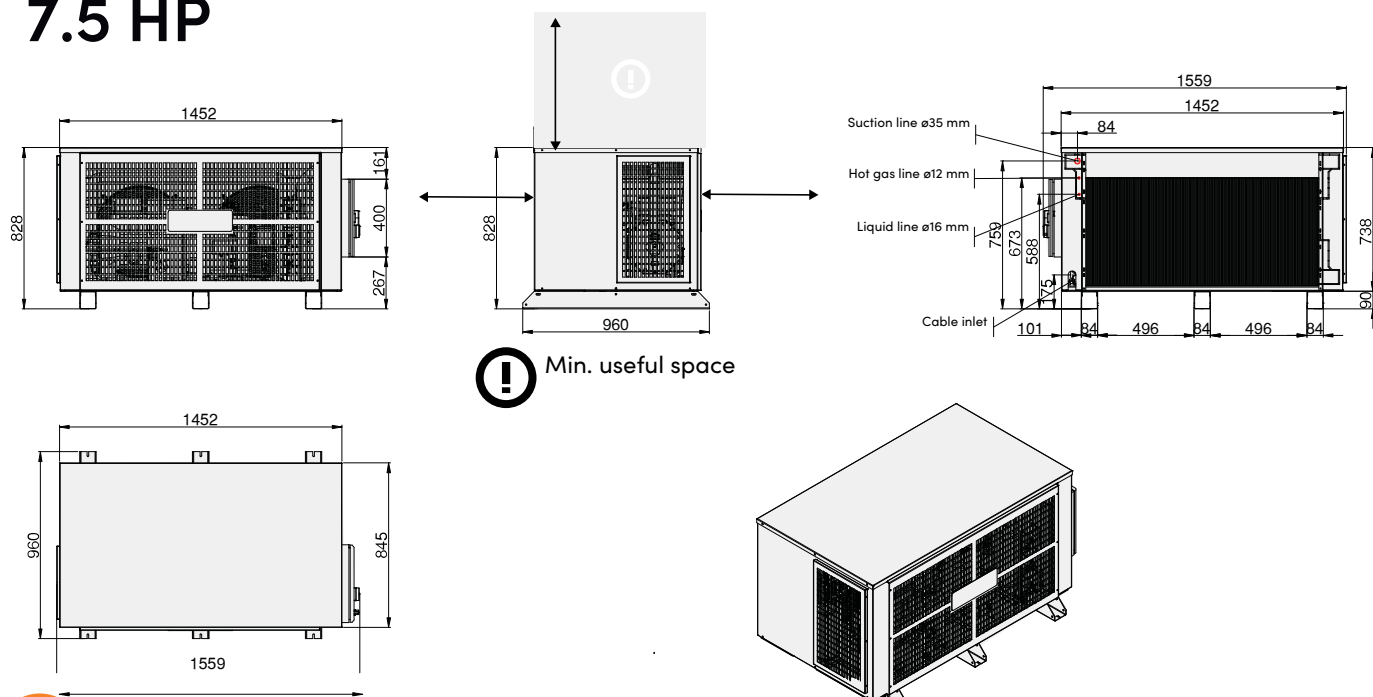

our technology,
your taste

Roll-in blast chiller

Models : CT40150PRORE & CT40200PRORE

400V 3N 50Hz

FUNCTIONS

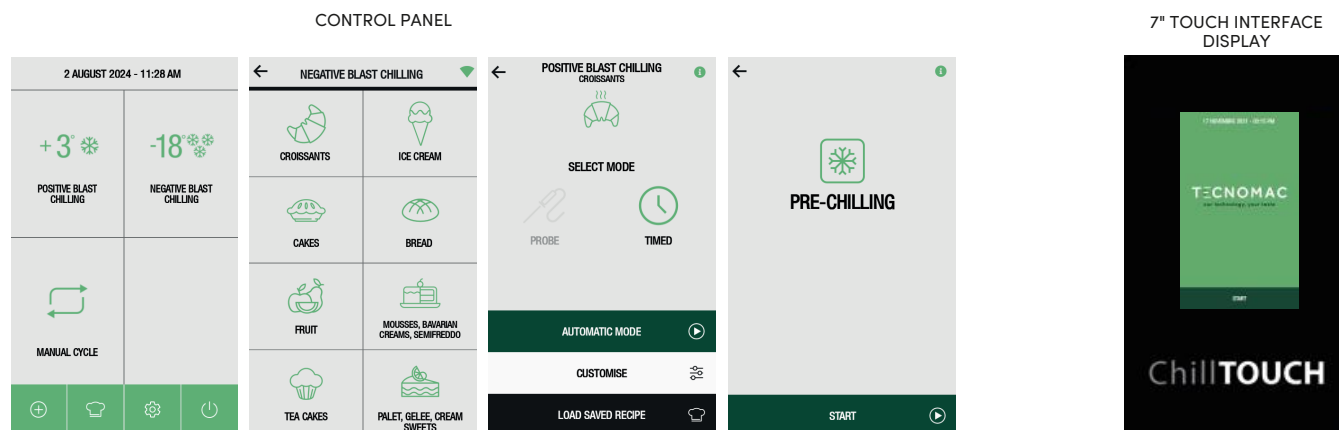

ELECTRICAL CONNECTIONS

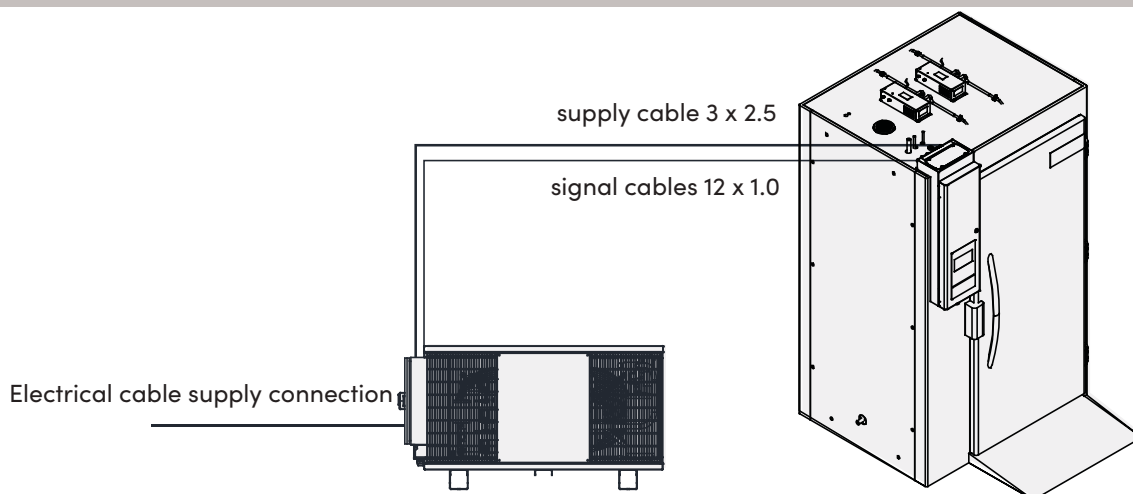

Connection to condensing unit NOT supplied by Tecnomac

- Tecnomac guarantees only the good functioning of the cabinet only. This option is not advised.
- Output signal supplied for switch on hot gas valve (if present)
- Input signal available for alarm coming from the condensing unit, which stops the machine.

our technology,
your taste

Roll-in blast chiller

Models : CT40150PRORE & CT40200PRORE

400V 3N 50Hz

EXCAVATION

Solution for less than 16h per day use

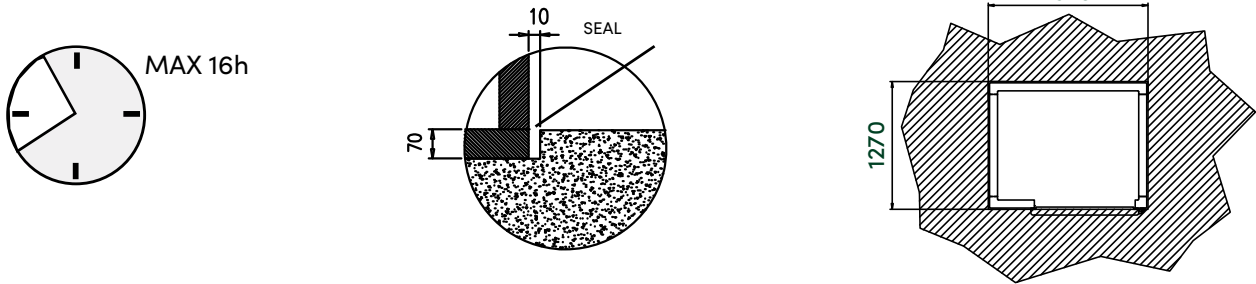

Solution for 24h per day use with removable grate

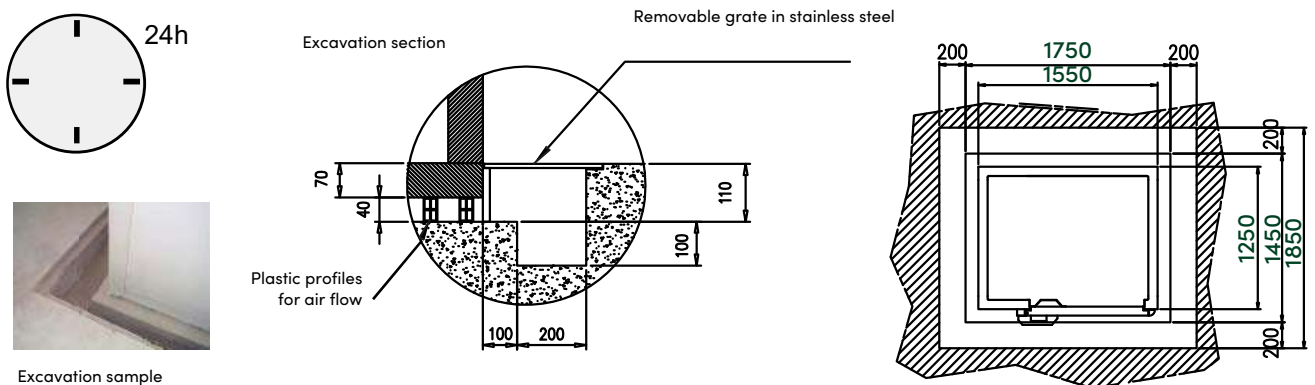

Solution for 24h per day use with ventilation chimneys

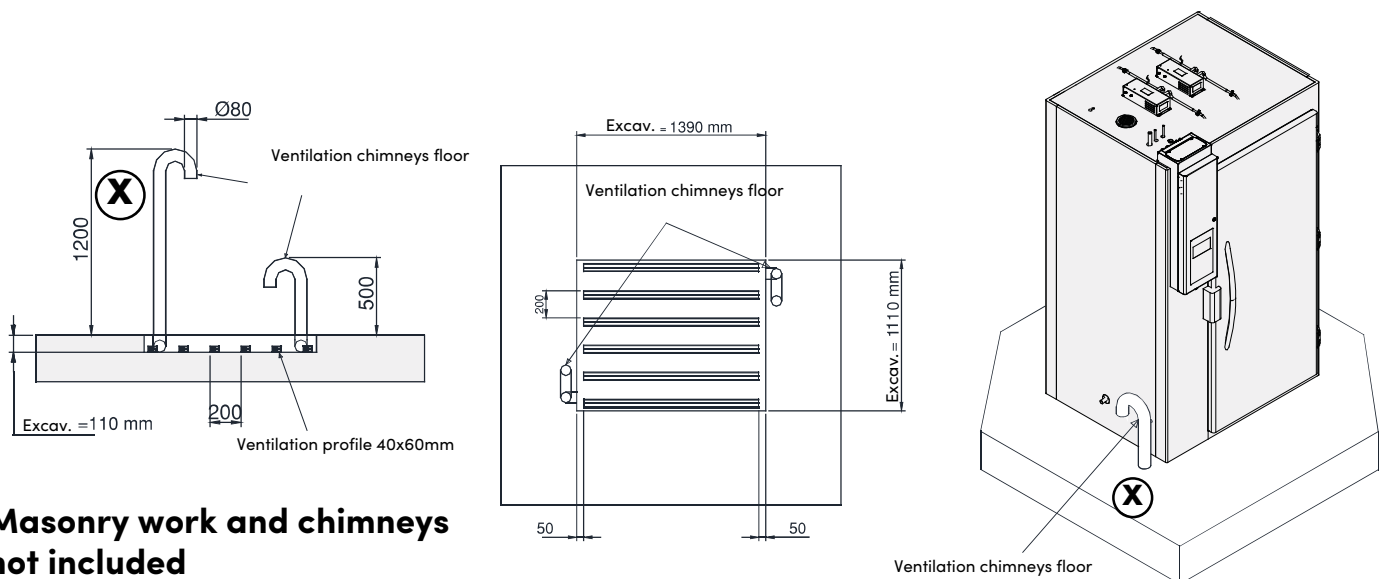

Masonry work and chimneys not included

