



TAYLOR®
CROWN®
SERIES

TOTALLY DIFFERENT.



Shown with Slushosity® Merchandising Materials
Consult Taylor distributor for merchandising options.

Shown with optional syrup storage cart



Rockton, Illinois 61072
800-255-0626
Phone 815-624-8333 Fax 815-624-8000
www.taylor-company.com
e-mail: info@taylor-company.com

International Office
Taylor Company S.r.l.
Roma, Italy
Tel: **+39-06-420-12002** Fax: +39-06-420-12034
e-mail: romeoff@taylor-company.com

Item No. _____

C300

Frozen Carbonated Beverage Freezer

Two Flavor

Features

Dispense a light, fluffy, high overrun slush product in a pressurized system from this modular, counter-top freezer. Optional non-pressurized system produces a wetter, lower overrun slush. Air is discharged out the top of the unit to accommodate tight counter space. Optional cart converts the unit to a self-contained floor model, and provides storage for the syrup.

Freezing Cylinder

Two, 7 quart (6.6 liter).

Dispensing Door

Clear plastic dispensing doors allow customers to see slush being made. Self closing draw handles are standard. Round dispensing nozzle conveniently fits the hole in domed lids.

Indicator Lights/Audible Alarm

Lights illuminate and audible alarm sounds to indicate loss of CO₂, water or syrup on the affected side. The opposite side will continue to operate when one side loses syrup. A snooze feature may be activated to silence the alarm for 30 minutes.

Automatic Defrost

Programmable defrost cycles allow the operator to select the time and frequency for defrosting each freezing cylinder independently. The defrost light flashes to warn customers not to draw product from the side that is being defrosted. At the end of the defrost cycle, the freezing cylinder automatically returns to the freeze-down mode.

Power Saver

During extended no-use periods, the Power Saver feature may be programmed for either Standby or Rest Mode. Standby Mode maintains product in freezing cylinder between 35 & 40°F (1.6 & 4.4°C) for quickest return to serving product. Rest Mode shuts down the refrigeration system for the most energy savings. Start and end times may be programmed independently for seven cycles.

Sure Set™ Flow Control

Automatically maintains brix settings by compensating for fluctuations in water, CO₂, and syrup pressures. Water flow is preset at the factory.

Electronic Viscosity Control

Slushtech™ is standard with our exclusive microprocessor based universal control which regulates refrigeration by measuring product viscosity.

Air Filter

Removable, cleanable air filter helps keep condenser clean for optimal refrigeration system performance.

Merchandising

LED display backlights translight and illuminates clear dispensing doors to draw customer attention. This display provides energy efficient, even, consistent lighting.

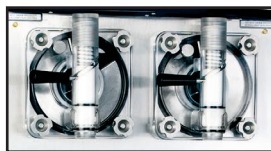

Optional
Non-pressurized doors

C300 Frozen Carbonated Beverage Freezer

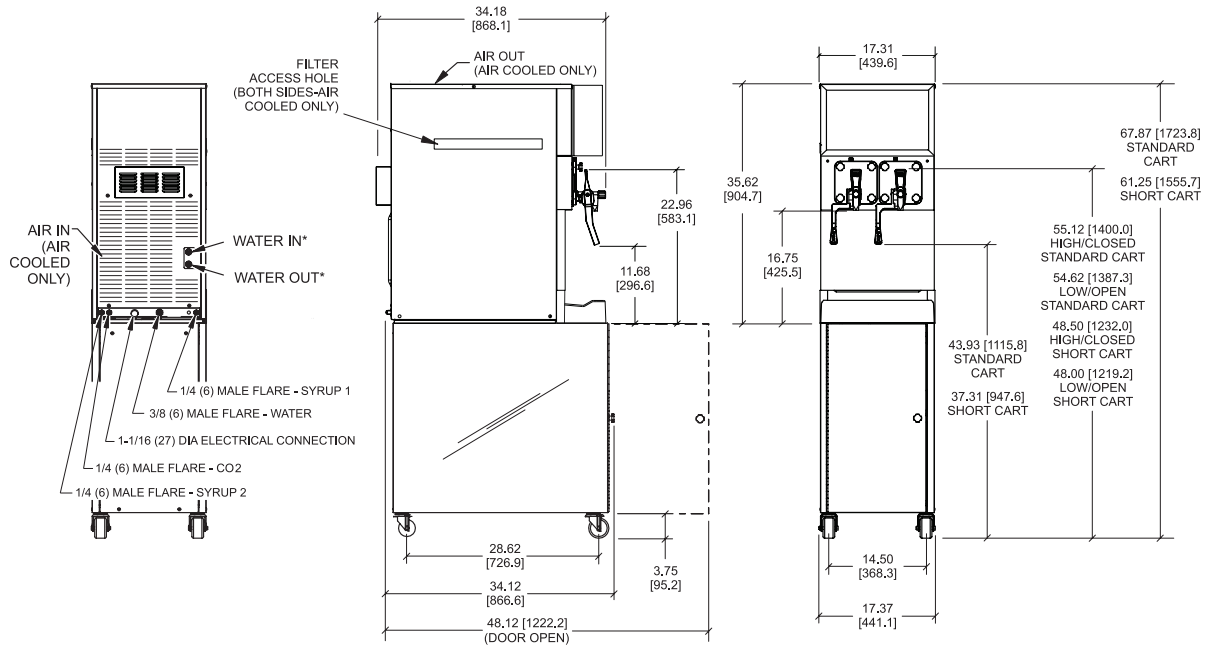

FIGURES IN BRACKETS INDICATE MILLIMETERS / DECIMAL AND FRACTIONAL DIMENSIONS EQUAL TO (PLUS OR MINUS 1/16 INCH [1.5mm] / *WATER COOLED ONLY).

| Weights | lbs. | kgs. |
|---------|---------|--------|
| Net | 335 | 152.0 |
| Crated | 383 | 173.7 |
| Volume | cu. ft. | cu. m. |
| | 23.9 | 0.68 |

| Dimensions | in. | mm. |
|-------------------|---------|-----|
| Width | 17-5/16 | 439 |
| Depth | 34-3/16 | 868 |
| Height | 35-5/8 | 905 |
| Counter Clearance | --- | --- |

*Designed to rest on a plastic pad directly on counter top or optional cart.

| Electrical | Maximum Fuse Size | Minimum Circuit Ampacity | Poles (P) Wires (W) |
|--------------------|-------------------|--------------------------|---------------------|
| 208-230/60/1 Air | 30 | 19 | 2P 3W |
| 208-230/60/1 Water | 30 | 18 | 2P 3W |
| 208-230/60/3 Air | 15 | 13 | 3P 4W |
| 208-230/60/3 Water | 15 | 12 | 3P 4W |
| 220-240/50/1 Air | 20 | 15 | 2P 3W |
| 380-415/50/3N- Air | 9 | 7 | 4P 5W |

This unit may be manufactured in other electrical characteristics. Refer to the local Taylor Distributor for availability.

(For exact electrical information, always refer to the data label of the unit.)
Continuing research results in steady improvements; therefore, these specifications are subject to change without notice.

Bidding Specs

Electrical: Volt _____ Hz _____ ph _____

Neutral: Yes No **Cooling:** Air Water NA

Options: _____

Specifications

Electrical

One dedicated electrical connection is required. See the Electrical chart for the proper electrical requirements. Manufactured to be permanently connected. Consult your local Taylor distributor for cord & receptacle specifications as local codes allow.

Beater Motor

One, 1/4 HP.

Refrigeration System

One, 18,000 BTU/hr compressor (nominal rating). R404A. (Actual BTUs will vary based on application.)

Carbonation System

Self-contained carbonation system. Syrup, water and CO₂ fittings connect at the rear of the machine.

Potable Water Pressure

Minimum 25 PSI for proper operation of carbonation system.

Air Cooled

Minimum Clearance: 3" (76 mm) on one side, 3" (76 mm) at the rear, and 12" (305 mm) on the top of the unit. Minimum air clearances must be met to assure adequate air flow for optimum performance.

Options

- Non-pressurized
- Syrup Tank Fittings
- Syrup Storage Cart Model C202: Includes shelves for storing BIB FCB syrups and mounting BIB pumps (not included).

Cart Dimensions

Width: 17-3/8" (441 mm)
 Depth: 33-1/8" (841 mm)
 Two Heights Available: 32-1/8" (816 mm) or 25-1/2" (648 mm)

Cart Weights

Net: 180 lbs. (81.6 kg)
 Crated: 204 lbs. (92.5 kg)



Taylor Company,
 Rockton, Illinois 61072
 815-624-8333 **800-255-0626** Fax 815-624-8000
www.taylor-company.com