

# STENXA Commercial Washer/Dryer



## 10 KG FRONT LOAD WASHER AND ELECTRIC DRYER

### Features and Benefits

- Payment options available - Coin, Token, Credit card and Payment App.
- Low water consumption of only 44.3 litres per wash, with full wash completed in 30 minutes.
- Energy saving 'High Speed Extract' spin cycle of 1,200 rpm producing 'G' forces in excess of 440 for greater water removal, resulting in reduced drying times and associated energy savings.
- 100% front service dryer.
- Touch push button controls robust and easy to use controls suitable for high volume multiple operator applications.

### SPECIFICATIONS

DIMENSIONS	
CAPACITY	10 kg washer, 10 kg dryer
WIDTH	683 mm
DEPTH	796 mm
HEIGHT	1,986 mm
NET WEIGHT	177 kg
OPERATION	
CYCLES	9 cycles, 3 soil levels
CYCLE LIGHTS	Yes
CYCLE TIME	26 - 30 minutes
CONTROLS	Touch push button controls
ACTIVATION	Coin, Token, Card or Payment App
WATER TEMPERATURE	Cold, Warm or Hot
MOTOR WASHER SPIN	1 hp, variable speed
SPEED WASHER	500 - 1,200 rpm, variable
WATER USE WASHER	speed 44.3 litres / wash
HEAT INPUT DRYER	4,000 w
CONSTRUCTION	
INNER BOWL WASHER	Stainless steel
OUTER BOWL WASHER	Stainless steel
OUTER CABINET	Steel
DRUM DRYER	Galvanised

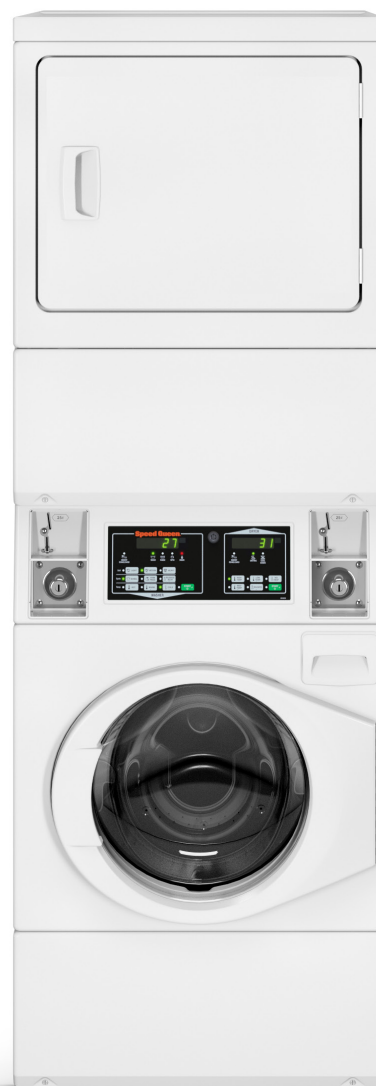

# STENXA Commercial Washer/Dryer



## TECHNICAL SPECIFICATIONS

### UTILITIES WASHER

10 AMP SINGLE PHASE 240 V 50 HZ
10 AMP CIRCUIT-BREAKER REQUIRED
1.8 M POWER CORD
HOT AND COLD WATER CONNECTIONS REQUIRED
1.2 M HOT AND COLD WATER HOSES SUPPLIED
WATER SUPPLY HOSE TAP ENDS 3/4 BSP THREADS
MAX HOT WATER CONSUMPTION 18.7 LITRE / CYCLE
MAX WATER CONSUMPTION 44.3 LITRE / CYCLE
MAX POWER DRAW 750 W / HR
DRAIN: 610 - 914 MM UPSTAND, 50 MM DIAMETER
WATER SUPPLY PRESSURE BETWEEN 140 - 820 KPA

### UTILITIES DRYER

20 AMP SINGLE PHASE	240 V 50 Hz
20 AMP	Circuit breaker required
1.8 M	Power Cord
FLUE DIAMETER	102 mm (4 in)
AIR FLOW	85 litres / second
MAX POWER DRAW	4,000 w / hour
OPTIONAL	Right or left side venting

### SHIPPING DIMENSIONS

WEIGHT	189 kg
HEIGHT	2,032 mm
WIDTH	762 mm
DEPTH	864 mm
	1.33 m <sup>3</sup>

A: 1,678* mm	B: 1,447* mm	C: 597 mm	D: 213 mm
E: 610 mm	F: 203 mm	G: 391 mm	H: 938* mm
I: 368* mm	J: 813* mm	K: 683 mm	L: 1,986* mm
M: 1,148* mm)	N: 52 mm	O: 704 mm	

\* With Leveling Legs Turned Into Base.

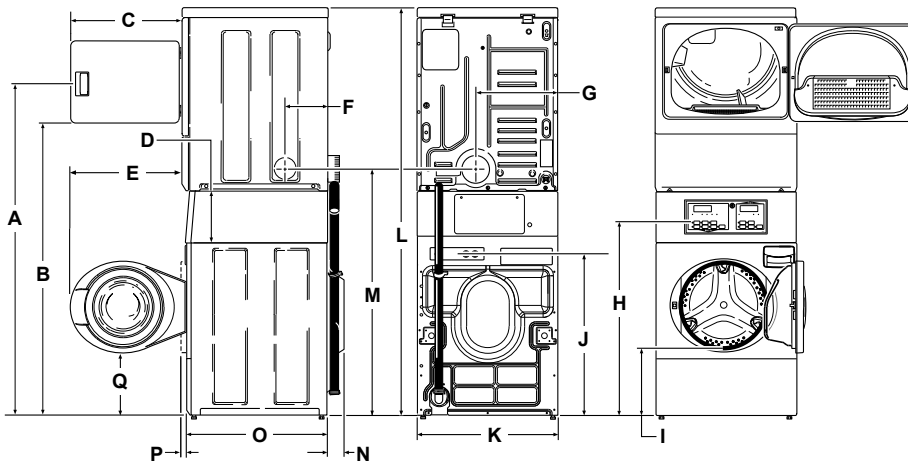

Speed Queen Equipment Sales  
 26 Theobald Street, Thornbury, VIC 3071  
 Ph: (03) 9495 1300  
 Ph: 1300 945 414  
 W: [www.speedqueensales.com.au](http://www.speedqueensales.com.au)  
 E: [info@speedqueensales.com.au](mailto:info@speedqueensales.com.au)  
 Servicing Victoria & Tasmania.