

SDESXR Commercial Dryer



10 KG MANUAL COIN OPERATED ELECTRIC DRYER

Features and Benefits

- Super strength, high security, double wrapped steel front money vault discourages and prevents vandalism.
- 100% front service dryer reduces maintenance time and costs ensuring maximum availability.
- Rear controls matching the SWNSX2 top load coin operated washer for perfect pairing of both capacity and style.
- 4,000 w heater element for fast, efficient drying.

SPECIFICATIONS

DIMENSIONS	
CAPACITY	10 kg
WIDTH	683 mm
DEPTH	711 mm
HEIGHT	1,114 mm
DRUM VOLUME	198 litres
NET WEIGHT	61 kg
OPERATION	
CYCLES	4 cycles, 3 fabric temperatures
CYCLE INDICATOR	Yes
CYCLE TIME	Variable to suit desired vend price
CONTROLS	Manual
ACTIVATION	Manual coin slide or token
HEAT INPUT	4,000 w
MOTOR	1/3 hp
ELECTRICAL	20 amp single phase
CONSTRUCTION	
DRUM	Galvanised steel
OUTER CABINET	Steel



SDESXR Commercial Dryer



TECHNICAL SPECIFICATIONS

UTILITIES

20 AMP SINGLE PHASE 240 V 50 HZ

20 AMP CIRCUIT-BREAKER REQUIRED

1.8 M POWER CORD

FLUE DIAMETER 102 MM (4 IN)

AIR FLOW 85 LITERS / SEC

MAX POWER DRAW 4,000 W / HR

OPTIONAL RIGHT OR LEFT SIDE VENTING

SHIPPING DIMENSIONS

WEIGHT 73 kg

HEIGHT 1,143 mm

WIDTH 775 mm

DEPTH 762 mm

0.67 m³

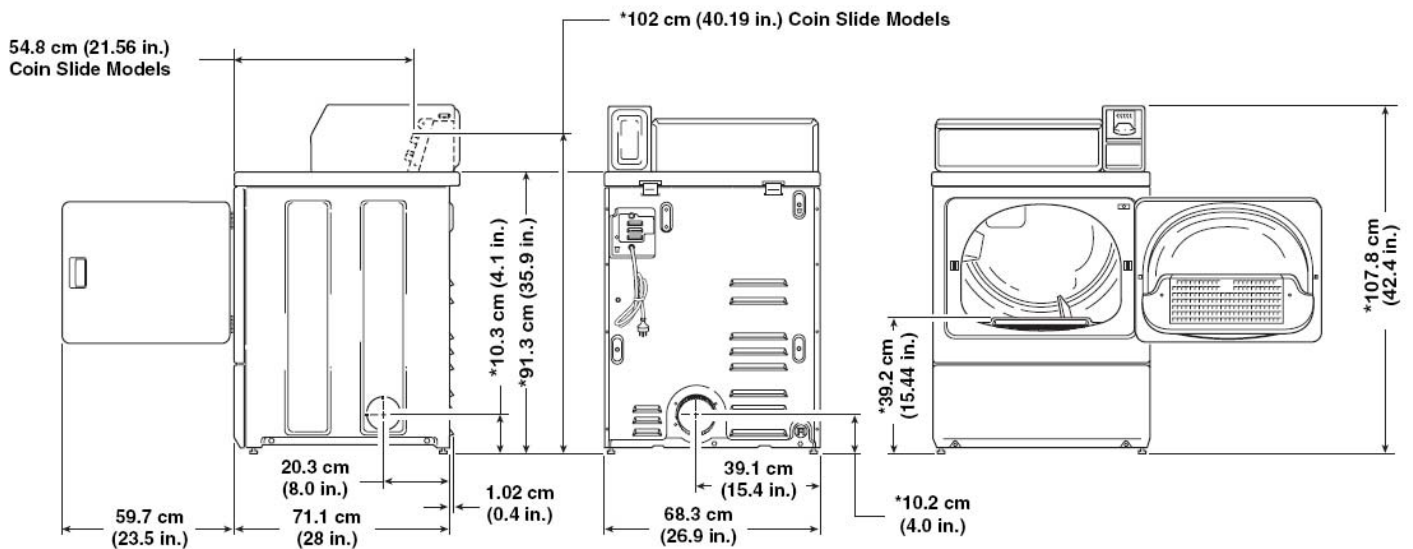

Speed Queen Equipment Sales
 26 Theobald Street, Thornbury, VIC 3071
 Ph: (03) 9495 1300
 Ph: 1300 945 414
 W: www.speedqueensales.com.au
 E: info@speedqueensales.com.au
 Servicing Victoria & Tasmania.