



SPACECOMBI MAGICPILOT BUILT-IN

MKN No.: SKE061R_BI_G2



MKN combi steamer compact 6 tray, Gastronorm 1/1 with MagicPilot operation system and integrated steam condensation Hood (Built In Model).

Product Advantages:

- **Built In Model** – Integrated Steam Condensation Hood.
- **MagicPilot** – Robust, wear-free, capacitive true colour touch screen.
- **Video assist** – Interactive user assistance with clips featuring professional chefs.
- **CombiDoctor** – Self-diagnosis programme.
- Hygienic rounded corners and cooking chamber door with insulated **triple glazing**.
- **RackControl** – Multi-timer.
- **GreenInside** – Indicates the energy and water consumption for each cooking programme.
- **AutoChef** – Up to 350 individual cooking programmes and manual operating system.
- USB interface.
- High speed centrifugal steam generation technology with heat recovery.
- **ClimaSelect** – Humidity and temperature control measurement.
- **WaveClean** – Automatic cleaning system (safe, easy, economical).
- **3 years warranty parts and labour.**

Installation requirements:

- Soft Water / Water supply / Connection to waste water provided by customer.
- If mineral content is high, reverse osmosis system may be advisable.

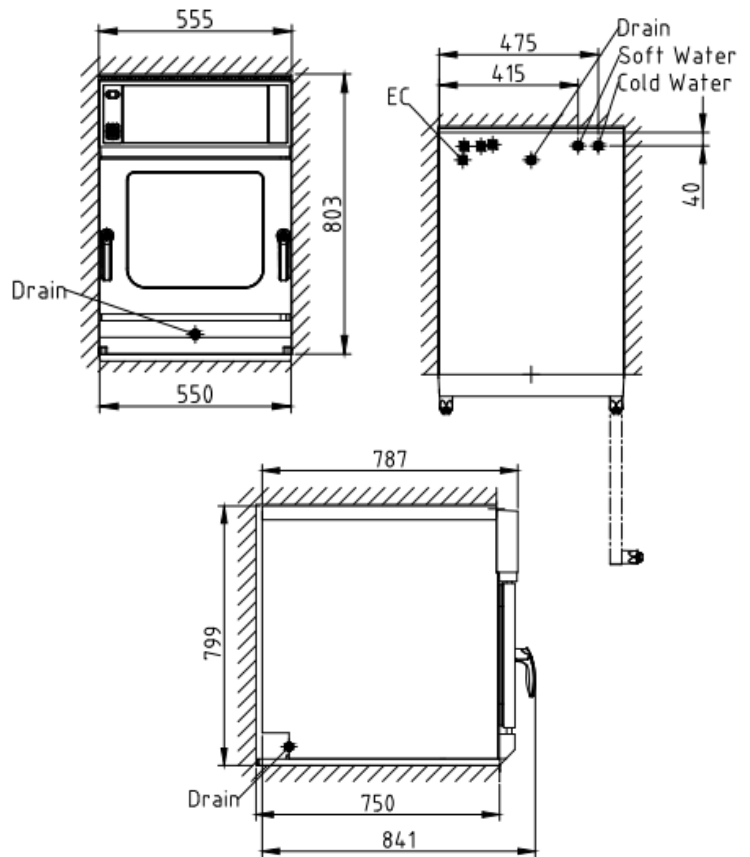

Technical Data:

Width x Height x Depth (mm)	550 x 799 x 787
Connected load (electrical) (kW):	7.8
Voltage (V) / EC:	415 3 phase AC
Recommended fuses (A):	3 x 20
Frequency range (Hz):	50
Soft Water connection:	DN 20 (R ¾" inside)
Water connection:	DN 20 (R ¾" inside)
Waterpressure (kPa):	200 - 600 (2 - 6 bar)
Drain connection:	DN 40
Gastronorm 1/1 (530 x 325 mm):	6 (max. 60 mm deep)
Plates Ø 28 cm:	12
Material housing:	1.4301
Material cooking chamber:	1.4301
Net weight (kg):	67
Heat emission latent (W):	1404
Heat emission sensitive (W):	936
Type of protection:	IPX 5

