

**INDUSTRY  
KITCHENS**

www.industrykitchens.com.au 1800 611 058

**sottoriva**

**INSTRUCTION MANUAL**

**Spiral mixer**

**Mod. *EVO* 130-160-200-250-300**

**Version: ENGLISH - Arc. 19**

**Code: 3529.0279.01**

**Revision: C dated 03/05/2017**

**Costruzioni Meccaniche SOTTORIVA S.p.A.  
Via Vittorio Veneto, 63 - 36035 MARANO VICENTINO (VI) ITALY  
Phone (+39) 0445.595.111 - Fax (+39) 0445.595.155  
Website: [www.sottoriva.com](http://www.sottoriva.com) - Email: [sottoriva@sottoriva.com](mailto:sottoriva@sottoriva.com)**



# Contents

<b>1. Introduction</b> .....	<b>5</b>
1.1 Identification .....	5
1.2 Introduction and purpose of manual .....	6
1.2.1 Using the Manual .....	6
1.3 Warranty conditions.....	7
1.4 Graphic conventions.....	7
1.5 Staff qualifications .....	9
1.6 General warnings .....	10
1.6.1 Customer's responsibility .....	10
1.6.2 Technical service .....	11
1.6.3 Spare parts.....	11
<b>2. Safety information</b> .....	<b>13</b>
2.1 General precautions - Training .....	13
2.2 General precautions – Skills and checks.....	13
2.3 General precautions - Prohibitions .....	15
2.4 General precautions - Workplace .....	15
2.5 Emergency fire regulations.....	16
2.6 Hygiene regulations for the use of lubricants .....	16
2.7 First aid regulations for the use of lubricants.....	17
<b>3. Handling and installation</b> .....	<b>19</b>
3.1 Shipping, handling and positioning.....	19
3.1.1 Precautions on receipt of the product .....	19
3.1.2 Handling instructions.....	19
3.1.3 Positioning instructions .....	21
3.1.4 Subsequent handling: not applicable to this machine.....	21
3.2 Unpacking and disposal of packaging materials .....	22
3.3 Installation area .....	22
<b>4. Product specification</b> .....	<b>23</b>
4.1 General description .....	23
4.2 Operational principles.....	25
4.3 Main components .....	25
4.4 Other components.....	25
4.5 Technical specifications.....	26
4.6 Power consumption.....	27
4.7 Noise level.....	27
4.8 Other emissions.....	27
4.9 Production and elimination of waste material .....	27
4.10 Operating conditions.....	28

4.11	Storage conditions.....	28
4.12	IP protection rating .....	28
4.13	Residual risks and special guards .....	28
4.13.1	Mechanical hazards .....	28
4.13.2	Electrical hazards.....	31
<b>5.</b>	<b>Preparation for use.....</b>	<b>33</b>
5.1	Assembly: Not applicable to this machine.....	33
5.2	Subsequent disassembly: Not applicable to this machine.....	33
5.3	Mounting: Not applicable to this machine.....	33
5.4	Installation .....	33
5.4.1	Hooking up to the line: Not applicable to this machine. ....	33
5.4.2	Connection to the mains power supply .....	33
5.4.3	Connection to the hydraulic circuit: Not applicable to this machine. ....	33
5.4.4	Connection to the pneumatic circuit: Not applicable to this machine. ....	33
5.4.5	Consumables: Not applicable to this machine. ....	33
5.5	Commissioning.....	34
5.5.1	Greasing: Not applicable to this machine.....	34
5.5.2	Adjustments: Not applicable to this machine. ....	34
5.5.3	Testing .....	34
5.6	First start-up .....	34
5.7	Running in .....	36
5.8	Inactivity and restart .....	36
<b>6.</b>	<b>User instructions .....</b>	<b>37</b>
6.1	Quick reference guide .....	37
6.2	Safety precautions.....	37
6.3	Checks before start-up .....	38
6.4	Correct use of the machine .....	39
6.5	Improper use .....	39
6.6	Operational limits.....	39
6.7	Machine controls .....	40
6.8	Ordinary functions .....	42
6.9	Stop functions.....	43
<b>7.</b>	<b>Maintenance instructions .....</b>	<b>45</b>
7.1	Safety precautions.....	45
7.2	General warnings .....	45
7.3	Periodic cleaning.....	45
7.4	Routine maintenance.....	46
7.4.1	Mechanical maintenance .....	47
7.4.1.1	Replacing the kneading tool drive belts .....	47
7.4.1.2	Replacing the bowl drive belts .....	49
7.4.1.3	Tension of belts.....	51
7.4.2	Electrical maintenance .....	53

7.4.2.1	Resetting a thermal cut-out.....	53
7.4.2.2	Replacing a fuse .....	53
7.4.3	Daily maintenance.....	54
7.4.4	Weekly maintenance: Not applicable to this machine .....	54
7.4.5	Monthly maintenance: Not applicable to this machine .....	54
7.4.6	Quarterly maintenance.....	54
7.5	Reactive maintenance .....	55
7.5.1	Replacements .....	55
7.5.1.1	Replacing the kneading tool motor .....	55
7.5.1.2	Replacing the bowl motor .....	56
7.5.1.3	Replacing the motor (ref. 3 <b>Fig. 13</b> ) of the hydraulic unit .....	57
7.5.1.4	Replacing the kneading tool.....	58
7.6	Troubleshooting.....	59
<b>8.</b>	<b>Dismantling and scrapping.....</b>	<b>61</b>
<b>9.</b>	<b>Attached documentation.....</b>	<b>61</b>
<b>10.</b>	<b>Reference manuals for third party components.....</b>	<b>61</b>
<b>11.</b>	<b>Safety signs installed on the machine.....</b>	<b>63</b>
<b>12.</b>	<b>List of components and spare parts.....</b>	<b>65</b>
12.1	List 1 .....	65
12.2	List 2.....	66
12.3	List 3 .....	68
12.4	List 4 .....	68
12.5	List 5 .....	68
12.6	List 6 .....	68
12.7	List 7.....	71
12.8	List 8 .....	72
12.9	List 9 .....	74
12.10	List 10.....	76
12.11	List 11.....	77
12.12	List 12.....	78
12.13	Hydraulic scheme and list of components .....	80



# 1. Introduction

## 1.1 Identification

**Fig. 1** on page 5 is an illustration of the nameplate, and **Fig. 2** on page 5 shows the position where it is riveted or screwed onto the machine; the plate is aluminium with indelible punched and printed data.

<b>C.M. SOTTORIVA S.p.A.</b>		Tel. (+39) 0445.595.111
Via Vittorio Veneto, 63		Fax (+39) 0445.595.155
36035 MARANO VICENTINO (Vicenza) - ITALY		Email:sottoriva@sottoriva.com
		VAT No. 00768890246
<b>Mod. no.</b>	<b>EVO (130-160-200-250-300)</b>	
<b>V</b> XXX <b>Hz</b> XX	XXXXXX	
<b>kW</b> XX	<b>A</b> XX 3 AC + (N) + T	
	<b>Mass</b> kg	
<b>Desc. 01:</b> Mixer for the production of food dough.	201_	<b>Desc. 01</b>
		CE

**Fig. 1 Nameplate**



**Fig. 2 Location of nameplate**

## 1.2 Introduction and purpose of manual

Thank you for choosing Costruzioni Meccaniche Sottoriva S.p.A., hereinafter called the Manufacturer; we are happy to have you as a customer and are sure that you will be satisfied with our product.

The present User and Maintenance Manual is an integral part of the consignment and is written for use by anyone working on or operating the machine.

The Manual has the purpose of providing all information required to:

- quickly identify the machine's component parts;
- correctly prepare the machine for use, operate it and service it;
- ensure the health and safety of all users and exposed persons;
- guarantee hygiene as regards the food processed in the machine.

The Manual also includes a **Spare Parts** section, should any part of the machine need to be replaced as a consequence of failure or expiry.

All the information, drawings, diagrams, tables and other contents of the Manual are reserved, and may not be reproduced in part or whole nor divulged to third parties, without the permission of the Manufacturer, who is the sole proprietor thereof.

### 1.2.1 Using the Manual

Carefully read the Manual before handling, installing, or operating the machine or working on it in any way.

The term "Manufacturer" refers always and only to Costruzioni Meccaniche Sottoriva S.p.A., while the generic term "Supplier" refers to other manufacturers of special parts of the machine.

The Manual must be kept with care for the service life of the machine, and must be consigned with the machine to any other future user or owner.

The Manual must be kept in the vicinity of the machine for consultation by its users.

Take care not to damage the Manual, remove pages, replace or delete information or modify its contents.

Furthermore, the Manual should be kept, preferably in an envelope, away from heat, direct light, humidity and corrosive agents.

**Note**

The Manufacturer reserves the right to make available at any time any further information he deems necessary to improving the operation and safety of the machine. All such information (modifications and addenda) must be considered an integral part of the Manual.

The Manufacturer also reserves the right to make any modifications to the machine itself that may be deemed suitable for any reason, without updating the Manual, unless the said modifications affect the operation of the machine.

### 1.3 Warranty conditions

The warranty conditions are stated in the contract of sale and as such have been accepted by the Customer on confirmation of the order.

### 1.4 Graphic conventions

Text in **boldface** is used to indicate important information.

Reference to figures and tables are made using a boldface number indicating the figure or table itself (e.g. **Fig. 1** or **Table 1**) and, where required, a letter or number, preceded by the abbreviation **ref.**, which identify - within the figure - the component described (e.g. **ref. A - Fig.1** or **ref. 1 - Fig 1**).

In order to direct the attention of the user in the correct and safe use of the machine, the Manual also uses the following symbols:

**Note**

Indicates an especially important note, instruction or precaution.

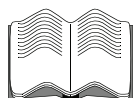
**Warning!**

Indicates an operation or situation which constitutes a hazard for the machine.

**Danger**

Indicates an operation or situation which constitutes a hazard for the health and safety of the user.



**Indicates that the operation in question is prohibited.**

The Manual also employs the following symbols to represent the ISE (Individual Safety Equipment) to be used when operating the machine.

The use of any given one of these symbols indicates that the article in question must be used during the operation.



Indicates that safety **glasses** must be worn during the operation in question.



Indicates that **gloves** must be worn during the operation in question.



Indicates that a **face mask** must be worn during the operation in question.



Indicates that **protective clothing** must be worn during the operation in question.



Indicates that **ear defenders** must be worn during the operation in question.



Indicates that a **helmet** must be worn during the operation in question.



Indicates that **safety footwear** must be worn during the operation in question.

## 1.5 Staff qualifications

The following professional qualifications are defined.



**Supervisor**

A member of the customer's staff charged with ensuring the observance of the instructions given in this Manual, with the purpose of ensuring not only the correct operation of the machine, but also full compliance with established safety regulations during operation.



**Qualified Technician**

A specialised technician, provided by the Customer or Manufacturer, authorised according to the circumstances to assemble, disassemble, install, adjust, commission, service and repair the machine.



**Operator**

A member of the customer's staff responsible for routine tasks needed to run the machine: actuation of controls, loading objects, monitoring production, cleaning surfaces and clearing blockages.



**Maintenance Technician**

A trained member of the customer's staff charged with scheduled maintenance and registers all such activities.

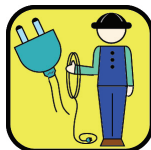

**Electrical Technician**

A trained member of the customer's staff charged with the adjustment, maintenance and repair of the machine's electrical equipment; also able to work on live equipment on the control switchboard and junction boxes.



**Manufacturer's Technician**

A specialised technician, provided by the Manufacturer, authorised according to the circumstances to assemble, disassemble, install, test, adjust, commission, service and repair the machine.

## 1.6 General warnings

All safety regulations given below must be rigorously observed by the machine's users.

At the customer's request, special training can be provided regarding the instructions in this manual, generally by the manufacturer's technical personnel when the machine is started up for the first time; the customer is responsible for selecting which individuals should take part in this training and checking afterwards if they have acquired sufficient knowledge to proceed with the tasks assigned to them.

The diagrams annexed to this Manual are for use exclusively for reactive maintenance and inspections.



**Prohibited!**

**It is prohibited to use the said diagrams to modify the machine in any way. Any proposed modifications must be approved directly by the Manufacturer, with a full technical specification of the machine and the reasons for the proposal; if approval is given, these tasks must only be carried out by staff employed or authorised by the Manufacturer.**



**Danger**

**Unauthorised tampering with or replacement of any part of the machine, and the use of any accessories, tools or consumables other than those recommended by the Manufacturer, may constitute a hazard and as such void the Manufacturer's liability, whether criminal or civil.**



**Supervisor**

The Customer must ensure that all users have fully understood the contents of this Manual and the meanings of the symbols located on the machine itself.

### 1.6.1 Customer's responsibility

**Unless otherwise specifically indicated in the contract, the Customer shall:**

- provide the logistical support for the positioning and operation of the machine;
- provide appropriate lifting equipment;
- provide all power connections (electrical, hydraulic, pneumatic);
- provide all tools and consumables;
- provide all lubricants.

## 1.6.2 Technical service

For technical assistance, please contact the Manufacturer's Technical Service Department.

The Manufacturer's telephone number is given at the foot of each page of this Manual; the fax number and website are indicated on the front cover.

## 1.6.3 Spare parts



**Note**

**The Customer must always and only use the original spare parts supplied by the Manufacturer.**

**When requesting materials from the Manufacturer, always specify the machine's model and serial number.**

**The Manufacturer is not liable for damage, injury or any other costs consequent on the use of non-original spare parts.**

The drawings, references, descriptions and serial numbers of all mechanical parts are given in “**12. List of components and spare parts**” on page 65.

For electrical, electronic and pneumatic equipment, refer to “**9. Attached documentation**” on page 61.





**This page intentionally left blank!**

## 2. Safety information

### 2.1 General precautions - Training

- Anyone charged with operating or servicing the machine should read the Manual through before doing so.
- Failure to fully observe the safety regulations in operating or servicing the machine may result in accidents for which the Manufacturer declines all liability.
- Note that, as given in established legislation:



**Any employee must observe the dispositions and instructions imparted by his employer.**



Supervisor

The User must ensure that the instructions given in this Manual have been read and understood by all operators and that they are employed as standard practice in the operation and servicing of the machine.

### 2.2 General precautions – Skills and checks

- Installation, commissioning and maintenance of the machine are to be performed solely by qualified and authorised technicians.
- The machine described in the Manual must be considered safe when monitored during operation.
- The users of the machine must notify their supervisors if they change the settings of the machine.
- Scrupulously observe at all times the signals and notices posted on the machine.
- Always use the ISE prescribed for each specific operation.
- The workplace must be adequately illuminated for the tasks in hand. Insufficient or excessive lighting is hazardous.
- Check that the power supply is of the specified type and is fully functional.
- While the machine is operating, make sure that no unauthorised persons approach the machine or its controls.
- When operating the machine, adopt all measures and precautions required to ensure that the machine and its component parts are not actuated unintentionally.
- If third parties (unauthorised persons or colleagues) are in the vicinity of the machine, the operator must monitor their safety and warn them of any hazards.

- After operation or during pauses, do not leave the machine powered up or unattended, even if it is not operative. Doing so may result in accidents.
- Before working on the machine, make sure that all power sources are physically disconnected.
- Keep the working and surrounding area clean and tidy; there must be no grease, oil, water and objects or materials which could cause an obstruction or hazard.
- Install a circuit breaker equipped with a magnetothermic switch upstream of the electrical power line to protect the cabling from shorts and overloads. For the specification of the circuit breaker, refer to the wiring diagrams provided by the Manufacturer along with this Manual.
- Provide adequate fire equipment in the working area, as specified by the Fire Service.
- Check the wear of all electrical cabling.
- Replace any damaged cables.
- Use adequately dimensioned cables as specified. For the specification of the cables, refer to the wiring diagrams provided by the Manufacturer along with this Manual.
- Check that all protections, guards and safety equipment are in place and fully operational.
- Restore and re-arm all protections and safety equipment immediately after the reason for their temporary removal has been resolved.
- Notify your supervisor in case of irregularity.

Note that, as given in established legislation:



**The worker is responsible for using the machinery, equipment and ISE correctly.**

## 2.3 General precautions - Prohibitions

The following actions are **absolutely prohibited**.



- Do not use the machine for purposes and with loads other than those specified and for which it has been constructed.
- Do not physically access the interior of the machine during operation or where it is prohibited.
- Do not remove or tamper with the protections and safety equipment under any circumstances other than those specifically indicated in this Manual.
- Do not attempt to repair, adjust, clean, lubricate or service any parts in motion.
- Do not wear clothes with loose sleeves, ties, scarves, rings, watches, bracelets or chains or any similar clothes or objects which may be entrained in the moving parts, resulting in serious injury.
- Do not modify the machine in any way.
- Do not store flammable materials, such as solvents, gas canisters, etc., in the vicinity of the machine.
- Do not work on the machine in any way while it is operating.
- Do not allow unauthorised persons into the working area, especially into the vicinity of machinery (even if the latter is not operating at the time).

## 2.4 General precautions - Workplace

The following standards apply in the workplace:

- Italian Legislative Decree 9/4/2008, n. 81 - Unified text regarding health and safety in the workplace; Italian Legislative Decree 3/8/2009, n. 106 - Supplements and corrections to Italian Legislative Decree 9/4/2008, n. 81, regarding health and safety in the workplace.
- European directives regarding health and safety in the workplace 89/391/CEE, 89/654/CEE, 89/655/CEE, 89/656/CEE, 90/269/CEE, 90/270/CEE, 90/394/CEE, 90/679/CEE, 93/88/CEE, 95/63/CE, 97/42/CE, 98/24/CE, 99/38/CE, 99/92/CE, 2001/45/CE, 2003/10/CE, 2003/18/CE and 2004/40/CE.
- Directive 2004/40/CE dated 29/4/2004, on minimum health and safety regulations in relation to exposure of operators to physical hazards (electromagnetic fields); Directive 2002/44/CE on minimum health and safety regulations in relation to exposure of operators to mechanical vibration; Directive 2006/25/CE dated 5/4/2006, on minimum health and safety regulations in relation to exposure of operators to physical hazards (optical radiation).
- Directive 91/156/CEE dated 18/3/1991, modifying directive 75/442/CEE on waste management; Directive 91/689/CEE dated 12/12/1991, regarding hazardous waste; Directive 94/62/CE regarding packaging and packaging waste; Directive n. 96 dated 2002, on electrical and electronic waste materials (RAEE); Directive 2008/98/CE dated 19/11/2008, regarding waste management.

## 2.5 Emergency fire regulations

In case of fire, use only CO<sub>2</sub> or powder extinguishers on electrical equipment. Do not direct jets of water at the machine as this can cause shortcircuits. If the fire is not extinguished immediately, take precautions against the dispersion of heated air, water, oil and other fluids. If the machine is equipped with pressurised tanks and hoses/pipes, they may explode if exposed to the flames for an extended period of time: make sure none of these fluids splash you.

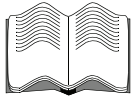

**Warning!**

**Provide CO<sub>2</sub> and powder extinguishers in the workplace.  
To prevent fire, keep the machine clean and clear of oil, solvents, rags, etc.**

**The use of powder extinguishers seriously damages the machine; use them only as a last resort.**



**Danger**

**Fire fighting staff must wear personal respirators when using CO<sub>2</sub> extinguishers.**



**Note**

**The use of extinguishers must be governed by a label.**

## 2.6 Hygiene regulations for the use of lubricants



**Supervisor**

The User must ensure that all operators are aware of the hygiene rules governing the use of lubricants.



**Danger**

**Refer to the safety sheets of the lubricants in use as regards the use of ISE.**

**Indicate any problems due to incompatibility between the lubricants and other materials.**



Refer to the safety sheets of the lubricants in use as regards their hygienic use.  
Keep the lubricants out of the reach of persons unauthorised to handle or use them.



Do not store lubricants in open or unlabelled containers.

## 2.7 First aid regulations for the use of lubricants

For first aid regulations, refer to the safety sheets of the lubricants in use.



**This page intentionally left blank!**

## 3. Handling and installation

### 3.1 Shipping, handling and positioning

#### 3.1.1 Precautions on receipt of the product

The machine is supplied by the Manufacturer ex-works. Before delivery to the shipping agent, the consignment is carefully inspected by the Manufacturer. The Manufacturer is not liable for damage or removal of parts incurred after delivery to the shipping agent.



**Machine components are normally packaged: any unpackaged parts must be shipped under cover. All component parts which may shift during shipping must be secured.**

On reception of the consignment, the Customer must:



**Check that the consignment corresponds to the specification of supply. Check that the machine has not suffered damage during shipping and that the packaging has not been tampered with and parts removed. If the consignment has been damaged or parts are missing, immediately notify the shipping agent and Manufacturer; document all such damage photographically.**

#### 3.1.2 Handling instructions



**Before handling the machine, check that the area is adequately illuminated and the floor is clear of obstacles, flat and even (no holes or depressions).**



**Use ropes at least 3 m long for lifting the machine. Before lifting the machine make sure that the ropes and lifting equipment are rated for the load in question, as well as being suited for the arrangement of the ropes themselves. In any case, the lifting apparatus must conform to current laws and regulations. For information on the weight of the machine, refer to Table 2 on page 26.**

The machine must be handled by staff trained in the use of lifting and handling equipment.

Handle the machine with the greatest care, avoiding collisions or impacts of any kind which may damage the machine or affect its operation.

In lifting or lowering the machine with the ropes, act slowly and gradually to prevent hazardous jerking movements as well as excessive momentum, which can be difficult to brake.



**The entire area concerned in lifting is to be considered a danger zone, by which is meant an area inside or around the machine in which the presence of a person constitutes a hazard for the safety and health of the person in question.  
Make sure that there are no exposed persons in the danger zone.**

To move the machine, proceed as follows:

- 1) pass a rope suited to lifting weights under the head at the point at which it meets the column, as in **Fig. 3** on page 20;
- 2) attach the rope as shown in **Fig. 3** to a lifting device (crane, bridge crane, hoist);
- 3) fit felt pads between the rope and the machine to prevent the ropes damaging the paint and the machine itself;
- 4) fit a wooden spacer (70-80 mm) between the side of the head and the rope, to prevent damage to the paint or the machine itself;
- 5) slowly lift the machine without jerking it.



**The machine can be moved using a fork lift truck; in this case, check that the machine is firmly secured to the pallet with straps.**

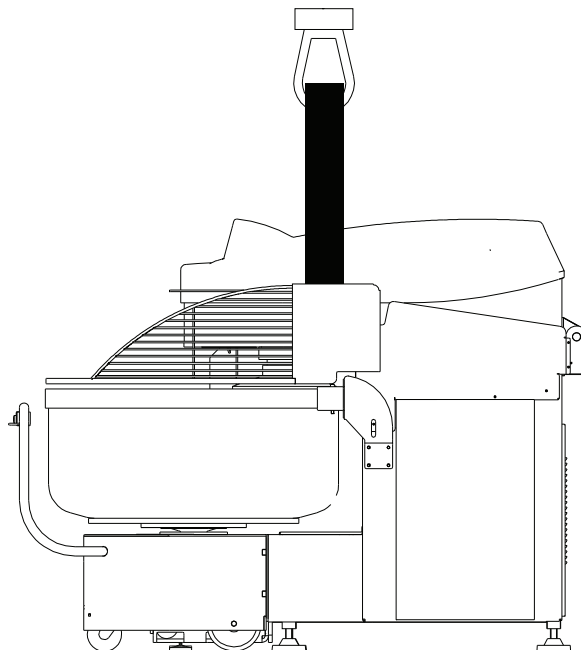

**Fig. 3 Handling**

### 3.1.3 Positioning instructions

Before positioning the machine, check that:

- the floor on which the machine is to be positioned is even and flat;
- the distance between the machine and the power supply point is as short as possible to prevent the cable becoming a hazardous obstacle to free movement;
- the area in which the machine is to be operated is adequately illuminated.

The machine, trolley included, must be positioned on the floor at the point specified for its installation, as shown in “**3.1.2 Handling instructions**” on page 19.

The machine must be lowered onto the floor as slowly as possible to prevent damage to either the machine or the floor itself.

With the exception of the front of the machine which is used by the operator and requires greater clearance, leave a space of at least 50 cm around the sides of the machine for access during maintenance and cleaning, thus ensuring the level of hygiene required.

**Once the machine has been placed in its operating position, verify that the distance between the wheels of the trolley and the floor is 1 mm, using the supplied plate ref. A Fig. 4 on page 21.**

If the distance will be different, adjust its stabiliser feet (ref. 9 - Fig. 5 on page 23 and ref. 2 Fig. 7 on page 24) with the provided nuts in order to minimise the motion of the machine while operating and to level the machine relative to the floor. The plate should be removed from the wheel easily.

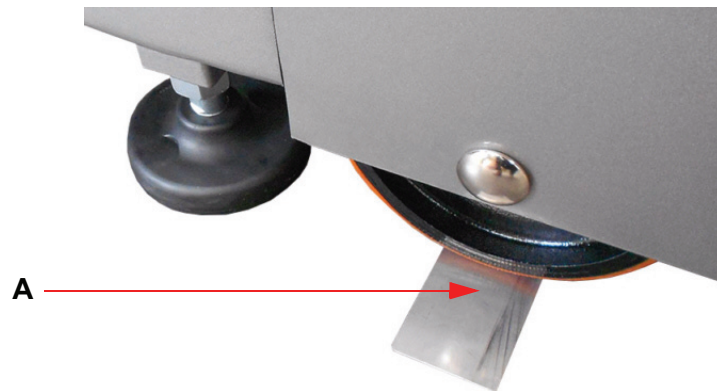

Fig. 4 Position control plate

### 3.1.4 Subsequent handling: not applicable to this machine.



**Given the considerable mass of the machine, make sure before pushing it that no-one is standing in the area through and into which it is to be moved.**

## 3.2 Unpacking and disposal of packaging materials

The machine is shipped with a variety of packaging materials. The Customer is obliged to dispose of them in accordance with established local legislation. The following packaging materials are used:

- cardboard
- tape
- extensible film
- bubble wrap
- wood
- steel nails and bolts
- PE barrier bags
- OPP straps marked Sottoriva
- PU foam

## 3.3 Installation area

The area in which the machine is to be installed, given that it is designed for the production and cooking of bakery products, must:

- permit access for the passage of the largest parts of the machine;
- be constructed in accordance with established legislation;
- have a flat, even floor capable of supporting the weight of the machine;
- be adequately illuminated inasmuch as insufficient or excessive lighting is hazardous;
- allow for an adequate circulation of fresh air;
- be equipped with an electrical plant which complies with established legislation, especially as regards the ground plant and electrical cabinet with its short circuit and overload equipment.

The nominal installed power of the machine is indicated on its nameplate, which is located as shown in **Fig. 2** on page 5.



**Qualified  
Technician**

The electrical plant must be installed, serviced and regularly inspected by a qualified electrician.

# 4. Product specification

## 4.1 General description

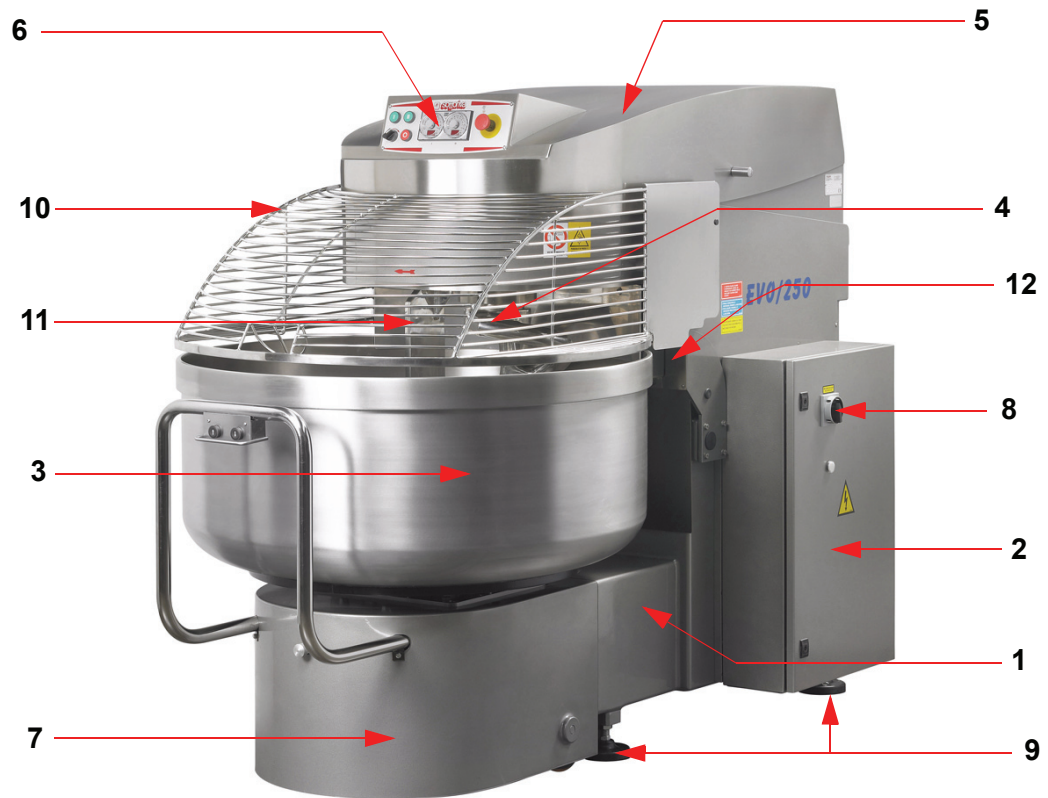

Fig. 5 Overview



Fig. 6 View of bowl interior

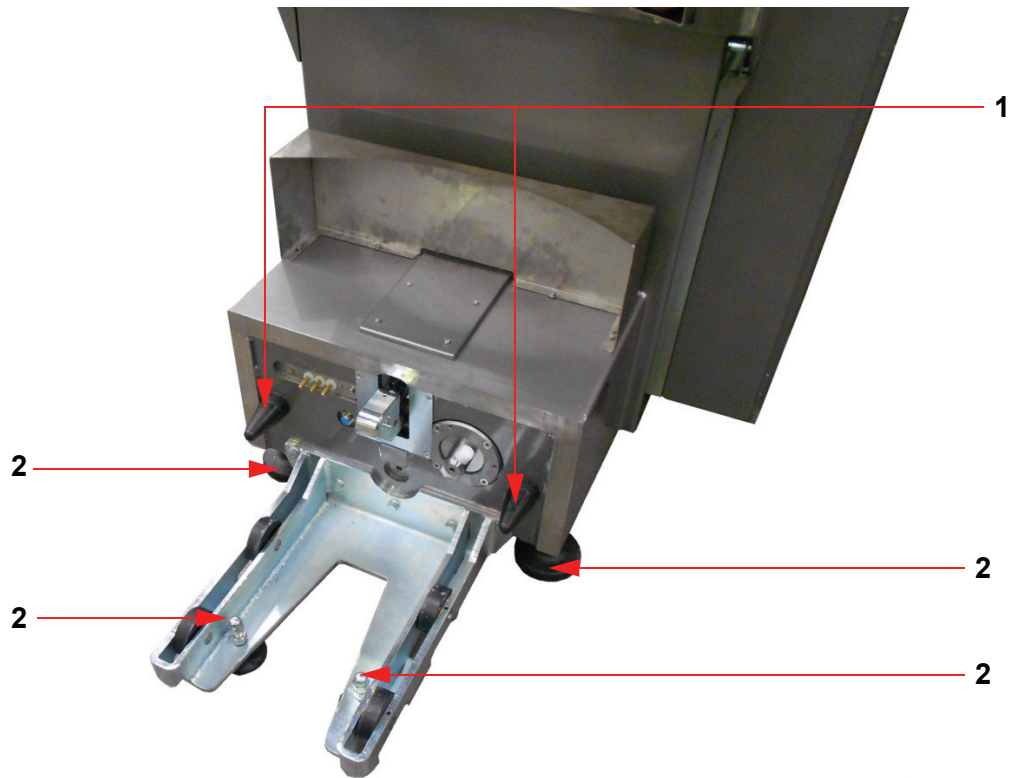

Fig. 7 Bowl attachment detail

The **EVO 130-160-200-250-300** (Fig. 5 and Fig. 6 on page 23) mixer is a machine for mixing ingredients, generally water, flour, yeast and salt with other secondary ingredients, and amalgamating them so as to obtain a homogeneous dough for further processing and cooking.

## 4.2 Operational principles

The machine's operation is divided into cycles of variable length as follows:

- 1) loading the machine with the ingredients;
- 2) mixing them;
- 3) unloading the dough;
- 4) cleaning the machine.

## 4.3 Main components

See Fig. 5 and Fig. 6.

The machine is composed of:

- a fixed frame (ref. 1) containing the transmission components for the kneading tool and the electrical cabinet (ref. 2);
- a mobile frame (ref. 7) containing the transmission components for the bowl and the bowl itself;
- a rotating bowl (ref. 3) which contains the ingredients to be amalgamated;
- a kneading tool (ref. 4) in the shape of an elongated spiral mounted on a vertical axis, for mixing and amalgamating the ingredients.

The kneading tool rotates clockwise, while the bowl can rotate in both directions; during the first few minutes of processing, the bowl should rotate in the opposite direction to the kneading tool, as this facilitates amalgamation of the ingredients.

The kneading tool is driven by a two-speed motor via a belt transmission; the bowl is driven by a different motor with its own drive belt.

## 4.4 Other components

With reference to Fig. 5 and Fig. 6, the machine is also composed of:

- a fixed top guard (ref. 5);
- a control panel (ref. 6);
- a main on/off switch (ref. 8);
- four feet (ref. 9) which stabilise the machine;
- an interlocked mobile guard (ref. 10) to prevent access to the bowl while it is moving;
- a metal column (ref. 11), mounted in parallel to the kneading tool, which breaks up the dough, thus aiding the amalgamation process;
- two guide rollers (ref. 12) on which the bowl runs.

## 4.5 Technical specifications

With reference to **Fig. 8**, **Table 1** shows the overall dimensions of the machine, while **Table 2** lists the power ratings of the motors and some other technical data. (\*) The dough making capacity given in **Table 2** refers to a water/flour ratio of 55/100 for flour of W=200 and P/L = 0.3.

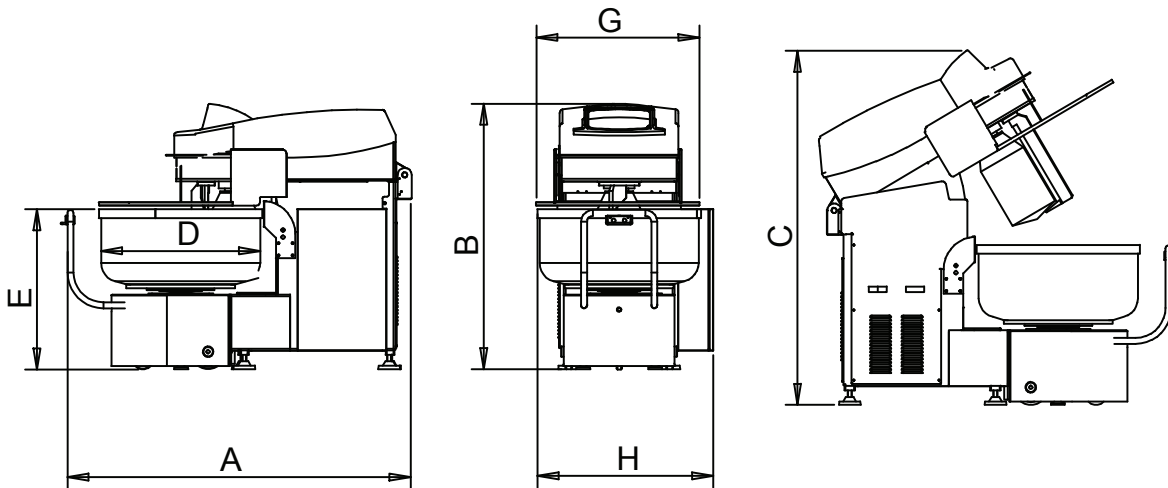

Fig. 8 Overall dimensions

MACHINE	A	B	C	D	E	G	H
EVO 130	1800	1470	1970	805	874	830	952
EVO 160	1960	1520	2017	900	913	930	1000
EVO 200	1960	1520	2017	900	953	930	1000
EVO 250	2170	1570	2070	1055	967	1085	1100
EVO 300	2170	1570	2070	1055	1007	1085	1100

Table 1 Overall dimensions

MACHINE	Volume of bowl L	Power of kneading tool motor kW		Power of bowl motor kW	Weight of weight kg	Weight including packaging kg
		1 speed	2 speed			
EVO 130	190	3	5.2	1.1	905	995
EVO 160	261	4.5	7.8	1.1	1090	1175
EVO 200	286	4.5	7.8	1.1	1100	1195
EVO 250	398	5.9	10.3	1.1	-	-
EVO 300	435	5.9	10.3	1.1	1260	1355

Table 2 Technical data

## 4.6 Power consumption

Refer to the wiring diagrams attached to this Manual.

## 4.7 Noise level

When running under no load, the machine emits a continuous equivalent acoustic pressure level of less than 70 dB(A); this measurement was made in the zone normally occupied by the operator as described in “**6.2 Safety precautions**” on page 37, at 1.6 m above the floor and at 1 m distance from the machine, in the direction of maximum emission.

The measurement was made with a HD 9019 K1 instrument (serial number 2809946804) composed of:

- integrator phonometer mod. HD 9016
- sensor HD 9019 S1

the specifications of which fall within the standards indicated below, as declared by the Supplier of the instrument with certificate of conformity regularly renewed on re-calibration of the instrument itself:

- IEC 651 CLASS 1
- IEC 804 CLASS 1
- IEC 225 FILTERS 1/3 OCTAVE
- IEC 537 FILTER WEIGHTING D
- BS 6402 DOSE

## 4.8 Other emissions



### EMISSION OF FLOUR DUST

For machines with mobile guard (ref. 10 - Fig. 5 on page 23) of the integral type, there are no significant risks, inasmuch as the residual apertures do not permit an appreciable emission of flour dust.

For machines with mobile guard (ref. 10 - Fig. 5) equipped with uniform apertures in steel dowel, the operator must always start and run the machine at low speed for at least 2 minutes to minimise the emission of flour dust, which would be considerably greater at higher speeds.

## 4.9 Production and elimination of waste material

The entire mass of dough produced by the machine is used in further processing. Any waste consisting of dough not further processed, must be collected and stored in suitable containers for disposal by a specialised contractor.



**Do not dispose of auxiliary materials used for cleaning (e.g. rags) in the sewers (via sinks, bowls, etc.) or dump them into the environment (into streams or onto the ground).**

**Such materials must be collected and stocked in suitable containers for disposal by a specialised contractor.**

## 4.10 Operating conditions

Unless otherwise specified in the contract of supply, the ambient operating temperature is in the range 0 °C to 50 °C; ambient humidity must be between 0% and 90% with no condensation.

The operating conditions must also be such as to ensure that the food products processed by the machine are not affected in any way during their exposure to the open air due to the action of factors such as drafts, dust or leaking fluids, condensation or aerosols.

## 4.11 Storage conditions



Supervisor

Up to the time of installation, the machine must be stored indoors, in a dry place, protected from the weather and in particular from dust, at a temperature in the range 0 °C to 50 °C, away from sources of heat and potential explosion. Refer to **Table 2** on page 26 for the weight of the machine, and check that the surface on which the machine is placed is designed and constructed to support it.

## 4.12 IP protection rating

The covers of electrical equipment exposed to external agents are rated IP 54.

## 4.13 Residual risks and special guards

In compliance with European Directive EN 453, we list below the residual risks and measures adopted to guard against them.

### 4.13.1 Mechanical hazards

The following significant mechanical hazards are present:

- crushing hazard;
- entrapment hazard;
- impact hazard;
- risk of loss of stability;
- shearing hazard.



**DANGER ZONE 1: area between the kneading tool (ref. 4 - Fig. 6 on page 23) and the rotating bowl (ref. 3 - Fig. 6) and between the kneading tool and the column (ref. 11 - Fig. 6).**

**NATURE OF RISK: shearing, entrapment, impact and crushing of upper extremities.**

**Protective measures:**

- The entire area of the bowl shown on the layout is protected by a mobile guard in impact resistant material which prevents the arms and hands from coming into contact with the kneading tool.
- The kneading tool may only be started up if the mobile guard is fully lowered.
- The guard is connected to an NC (normally closed) microswitch, which forces the opening of the microswitch's contacts when it is opened; opening the microswitch's contacts cuts off power to the motors and stops the machine at once.



**The safety microswitch must trip whenever any point of the mobile guard's perimeter is more than 75 mm distant from the edge of the bowl. An aperture at the part of the guard furthest away from the kneading tool allows the machine operator to test the dough manually; this opening may never be used by the operator to access the tool with his hands for any reason.**



**DANGER ZONE 2: area between the frame (ref. 1 - Fig. 5) and the bowl (ref. 3 - Fig. 5).**

**NATURE OF RISK: entrapment of the upper extremities.**

**Protective measures:**

- The risk has been prevented by providing adequate clearance between the bowl and the frame, as per the state of the art of the technology in question.
- When cleaning the area in question, or beneath the bowl, refer to .



**DANGER ZONE 3: area covered by the mechanism responsible for the forward travel of the bowl (ref. 3 - Fig. 5 on page 23).  
NATURE OF RISK: entrapment of the upper extremities.**

**Protective measures:**

- Not applicable to the machine, inasmuch as the bowl forward travel mechanism is protected by a fixed guard, which moves with the bowl and prevents the upper extremities from accessing its moving parts.



**DANGER ZONE 4: area covered by the mechanism responsible for the forward travel, positioning and adjustment of the kneading tool holder.  
NATURE OF RISK: shearing, entrapment, impact and crushing of upper extremities.**

- Not applicable to the machine inasmuch as the kneading tool holder is fixed.



**DANGER ZONE 5: area between the guide rollers (ref. 12 - Fig. 5) and the bowl (ref. 3 - Fig. 5).  
NATURE OF RISK: entrapment and trapping of upper extremities.**

- Not applicable to the machine inasmuch as the area in question is protected with fixed guards.



**DANGER ZONE 6: area between the rotating bowl (ref. 3 - Fig. 5) and the mobile guard (ref. 10 - Fig. 5).  
NATURE OF RISK: crushing of the upper extremities.**

**Protective measures:**

- The risk has been prevented by implementing adequate clearances between the upper edge of the bowl and the edge of the mobile guard when it is closed (max 25 mm).

**Note**

**All other moving parts, such as drive mechanisms, belts, chains, etc. have been rendered inaccessible by means of fixed guards. These guards may only be removed under circumstances expressly specified and by the qualified technicians indicated in each case in this Manual.**

#### 4.13.2 Electrical hazards

All electrical equipment, including the control and signalling equipment, has been designed and constructed in compliance with the safety regulations and technical specifications of EN 60204-1.





**This page intentionally left blank!**

## 5. Preparation for use

**5.1 Assembly:** Not applicable to this machine.

**5.2 Subsequent disassembly:** Not applicable to this machine.

**5.3 Mounting:** Not applicable to this machine.

### 5.4 Installation

**5.4.1 Hooking up to the line:** Not applicable to this machine.

#### 5.4.2 Connection to the mains power supply



Qualified  
Technician

The operations described below must only be carried out by a qualified technician.



**Warning!**

**Make sure that the mains voltage is as required for the machine and clearly indicated on the machine nameplate.**

The machine must be connected to the mains power supply in compliance with established regulations, and with reference to the data given in this Manual.

For the connection, the machine is provided with a CEI 20-22 cable and EEC plug with the number of poles indicated on the nameplate.

Connect the machine to the ground system and not to the gas or water pipes or any other non-specific metal structures.

The power supply cable must be kept away from hot and moving parts. It must not be an obstacle to the free movement of staff or materials in the working area.

**5.4.3 Connection to the hydraulic circuit:** Not applicable to this machine.

**5.4.4 Connection to the pneumatic circuit:** Not applicable to this machine.

**5.4.5 Consumables:** Not applicable to this machine.

## 5.5 Commissioning

**5.5.1 Greasing:** Not applicable to this machine.

**5.5.2 Adjustments:** Not applicable to this machine.

### 5.5.3 Testing



Manufacturer's  
Technician

The machine is factory tested by the Manufacturer before shipping.

## 5.6 First start-up



Qualified  
Technician

The operations described below must only be carried out by a qualified technician.

After positioning the machine, proceed as follows in the specified order, with reference to **“6.7 Machine controls” on page 40**:

- 1) Make sure that the machine voltage displayed on the nameplate corresponds to the line voltage of the installation site; if it does not, stop the electrical installation procedure and contact the distributor or Manufacturer immediately.
- 2) Connect the plug to the power socket.
- 3) Make sure the machine rotates in the right direction; to do this, proceed as follows:
- 4) turn the main switch (**ref. 1 - Fig. 11** on page 40) to 1;
- 5) press the head up button (**ref. 6 - Fig. 11**);
- 6) when the head is fully up (**Fig. 6**) the bowl carriage (**ref. 7 - Fig. 5** on page 23) is automatically released;
- 7) Push the carriage (**ref. 7 - Fig. 5**) carefully up to the frame (**ref. 1 Fig. 5**) so that the pins (**ref. 1 - Fig. 7** on page 24) engage with the holes in the carriage itself;
- 8) lower the guard (**ref. 10 - Fig. 5**) if it is up (the machine will not start otherwise!);
- 9) press the head down button (**ref. 7 - Fig. 11**);
- 10) set a minimum time on the timer (**ref. 6 - Fig. 12** on page 41);
- 11) press the low speed start button (**ref. 1 - Fig. 12**);
- 12) stand in front of the machine as shown in (**Fig. 10** on page 38), and check that the spiral kneading tool (**ref. 4 - Fig. 6**) is turning clockwise.
- 13) Press the button (**ref. 3 - Fig. 12**) to stop the machine.
- 14) Turn the main switch (**ref. 1 - Fig. 11**) from 1 to 0.
- 15) Disconnect the plug from the power socket.

- 16) If the kneading tool is turning clockwise, the first start-up procedure is concluded. If not, in other words if the kneading tool turns anticlockwise, proceed as follows:
- 17) undo the screws shown in **Fig. 9** on page 35.
- 18) open the power plug.
- 19) swap the brown and black wires.

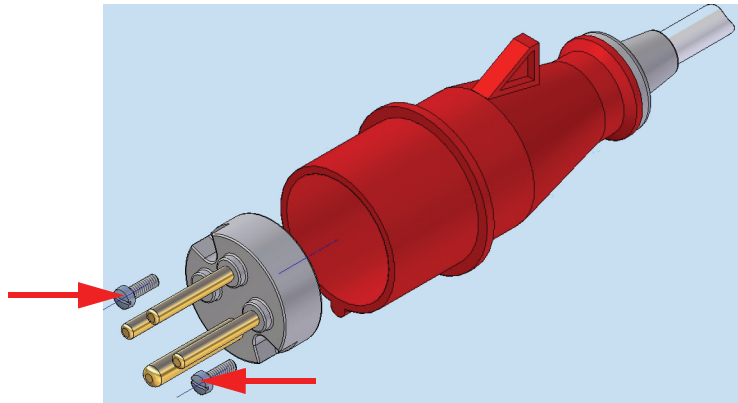

**Fig. 9** Mains plug



**Note**

**In case of three-phase + neutral + ground power connection, there are two black wires. In this case it does not matter which of the black wires is swapped with the brown wire; if the cable is three-phase + ground there is only one black wire; swap it with the brown wire.**



**Warning!**

**Never disconnect the yellow-green (ground) or blue wires or change their positions.**

- 20) Close the plug using the screws as shown in **Fig. 9**.
- 21) Reconnect the plug to the power socket.
- 22) Check the rotation direction of the kneading tool again, as indicated in point 3).

## 5.7 Running in



Qualified  
Technician

After **50 hours of operation** from first start up, check and adjust, if necessary, the tension of all belts, with reference to “**7.4.1.3 Tension of belts**” on page 51.

## 5.8 Inactivity and restart



Operator

If the machine must be put out of service for any reason, proceed as follows:

- 1) disconnect the plug from the mains power socket;
- 2) clean the machine with reference to “**7.3 Periodic cleaning**” on page 45;
- 3) cover the machine to protect it against dust;
- 4) post an “Out of service” notice on the machine.



Note

**Before restarting the machine after such a period of inactivity, check that the machine is clean as required for food hygiene.**



Qualified  
Technician

The machine must then be started up by a qualified technician, with reference to “**5.6 First start-up**” on page 34.

## 6. User instructions

### 6.1 Quick reference guide

- **In case of danger**, press the mushroom head button (ref. 5 Fig. 12 on page 41) to run an emergency stop.
- **To restart the machine:**
  - 1) solve the problem;
  - 2) reset the mushroom-head button (ref. 5 Fig. 12);
  - 3) press the low speed start button (ref. 1 Fig. 12);
  - 4) wait for two minutes;
  - 5) press the high speed start button (ref. 2 Fig. 12).
- **To stop the machine**, press the stop button (ref. 3 Fig. 12).
- **To switch off the machine:**
  - 1) press the machine stop button (ref. 3 Fig. 12);
  - 2) turn the master switch counterclockwise (ref. 1 Fig. 11 on page 40);
  - 3) disconnect the plug from the mains power socket.

### 6.2 Safety precautions

The supervisor must:



Supervisor

- 1) **inform and train** all operators regarding the correct, safe use of the machine;
- 2) **ensure** that all the instructions given in this Manual are scrupulously observed by all operators;
- 3) **supply** all prescribed ISE to all operators;
- 4) **ensure** that the ISE is used effectively and correctly.



Danger

**In order to reduce powder emissions to a minimum:**

- 1) **handle packaged products with care**, pouring them into the bowl at the lowest possible height above its base;
- 2) **open the packages with care** inside the bowl, so as to minimise the amount of time that flour dust is emitted;
- 3) **use temporary lids** to reduce any openings and potential release of flour.

The working position normally occupied by the operator for short periods of time is shown in Fig. 10 on page 38.

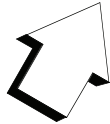

Fig. 10 Operator position



When loading flour into the bowl, the operator must wear a **dust mask**.



If the running noise of the machine increases above the value declared by the Manufacturer in “**4.7 Noise level**” on **page 27** due to wear of its parts, the operator must wear **ear defenders**. The supervisor must have worn components replaced with original spare parts, as per the instructions given in this Manual.

### 6.3 Checks before start-up



Operator

**Before** starting work, run the following checks:

- 1) make sure all fixed guards are in place;
- 2) make sure the bowl's mobile guard is in place (**ref. 10 Fig. 5** on page 23);
- 3) make sure that all safety equipment is in place and operational: mobile guard interlock and mushroom-head button (**ref. 5 Fig. 12** on page 41) to trigger the emergency stop;
- 4) make sure that all hold-to-run controls are in place and operational (**ref. 6 and ref. 7 Fig. 11** on page 40);
- 5) make sure that the main switch (**ref. 1 Fig. 11**) and power socket are in place and operational.

## 6.4 Correct use of the machine

The machine in this Manual should be considered as compliant with all regulations relating to suitability for food processing in force at the moment it is shipped by the Manufacturer; this suitability depends over time on careful cleaning, at least daily, and on regular service and inspection, including immediate replacement of any parts in contact with foodstuffs (dough, flour, water, etc.) which may be damaged, worn or no longer suited to the hygienic treatment of foodstuffs.



**The kneading process must start slowly for at least 2 minutes, to prevent flour which is not sufficiently bound with the water being ejected in powder form from the bowl, since inhalation of flour can be noxious over the long term.**

## 6.5 Improper use

The following prohibitions do not cover all possible incorrect uses of the machine, but relate only to reasonably probable ones.



**Prohibited!**

**Do not load the machine beyond the kneading capacity shown in Table 2 on page 26.**

**Do not run the machine at any speed other than that set by the Manufacturer. Obtain the Manufacturer's permission before modifying the speed settings.**

**While the kneading tool head is rotating or lifting (where applicable), keep your hands away from all moving parts.**

**Do not use spatulas or scrapers to extract the dough from the machine.**

## 6.6 Operational limits

The total weight of the ingredients should not exceed the nominal dough capacity given in **Table 2**.

Since flour is much less dense than water, the nominal capacity of the bowl is determined on the basis of a water/flour ratio of 0.55 and on the assumption that the flour is loaded into the bowl before the water (thus wetting the flour and increasing its density, reducing its volume and reducing the amount of flour dust emissions).

## 6.7 Machine controls



Fig. 11 Main switch and control panel

The machine is controlled by:

- a master switch (**ref. 1 Fig. 11**) on the electrical cabinet's fixed guard;
- a control panel (**ref. 2 Fig. 11**), located on the front panel of the kneading tool head;
- a control panel (**ref. 3 Fig. 11**), on the carriage's handle;
- an electrical cabinet (**ref. 8 Fig. 11**), at the side of the machine.

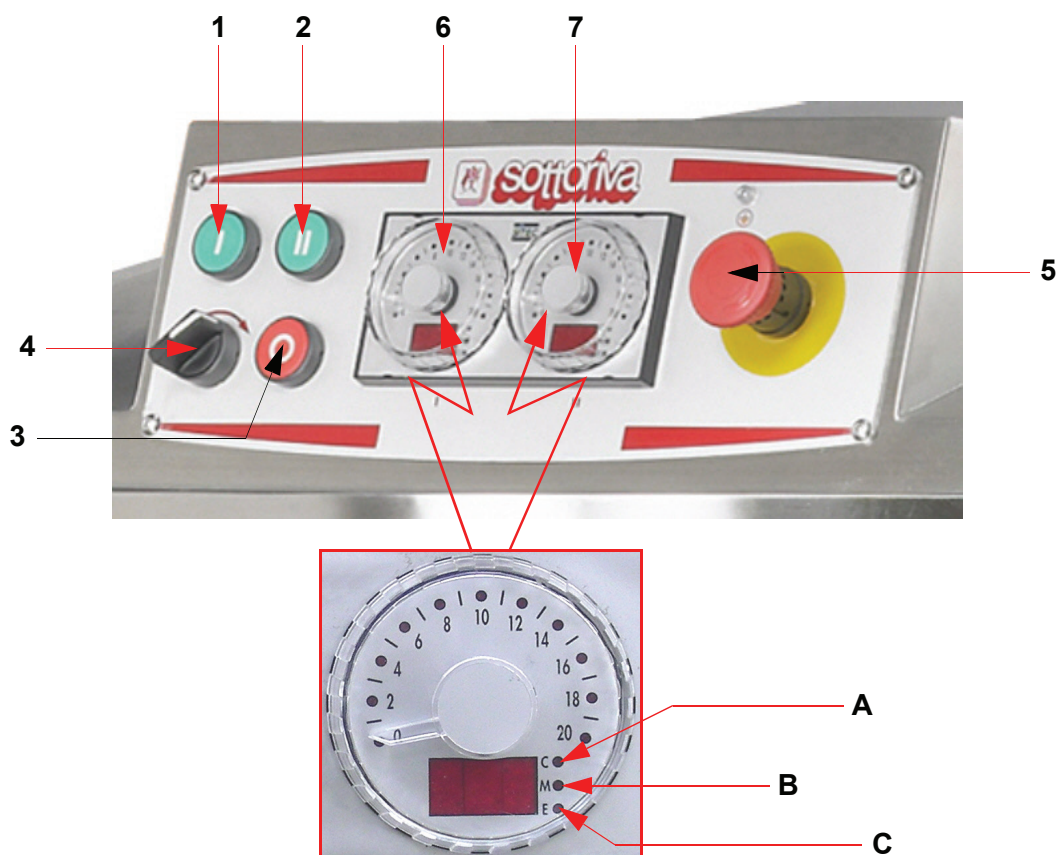

Fig. 12 Control panel

The control panel includes:

- a start button (**ref. 1 - Fig. 12**), for low speed operation;
- a start button (**ref. 2 - Fig. 12**), for high speed operation;
- an emergency stop button (**ref. 3 - Fig. 12**);
- a three position switch (**ref. 4 - Fig. 12**) which runs the bowl in both directions (only enabled at low speed);
- a white warning light (**ref. 4 - Fig. 11** on page 40) which indicates the presence of electrical current;
- a mushroom-head pushbutton (**ref. 5 - Fig. 12**) for emergency shut-down;
- a timer for manually setting the duration of the low speed cycle (**ref. 6 - Fig. 12**);
- a timer for manually setting the duration of the high speed cycle (**ref. 7 - Fig. 12**);

## Timer modes

### Automatic “COUNT” mode

Turn the collars to set the durations of the low and high speed cycles. Press the start button to start the count, which is indicated by the flashing of the “C” (COUNT) led **ref. A Fig. 12** on page 41 and the indicator LED bar or displays (where applicable).

### “MANUAL” mode

To operate the machine manually, turn the collar all the way anticlockwise. This mode is indicated by the “M” (MANUAL) led **ref. B Fig. 12**. To cut out the automatic low speed count, turn the LH collar to the “MANUAL” position; do the same with the RH collar to cut out the automatic high speed count. The machine is now controlled completely manually with the external start and stop controls.

### “EXCLUDED” mode

When the collar is set to 0, the “E” (EXCLUDED) led **ref. C Fig. 12** lights up. In this case the machine may not operate with the external start and stop controls. If, for example, the LH (low speed) timer collar is set to “EXCLUDED”, the machine will run only at high speed.

## 6.8 Ordinary functions



Operator

The ordinary functions of the machine are controlled by the Customer's qualified operators.

The operator proceeds as follows:

- 1) Load the bowl with the ingredients and push the carriage (**ref. 7 Fig. 5** on page 23) carefully up to the frame (**ref. 1 Fig. 5**) so that the pins fit into the holes in the carriage itself.  
A slight ovalization of the holes on the carriage, caused by wear resulting from repeated insertion and removal from the machine, is not a cause for concern. If the ovalization becomes accentuated, contact the manufacturer to arrange the required maintenance work.
- 2) Connect the plug to the power socket.
- 3) Turn the main switch (**ref. 1 Fig. 11** on page 40) to 1.
- 4) Check that the warning light (**ref. 4 Fig. 11**) is on.
- 5) Lower the mobile guard (**ref. 10 Fig. 5**) if it is raised; the machine will not start if the guard is not down.
- 6) Hold down the button (**ref. 7 Fig. 11**), the carriage will engage automatically and the head will lower.
- 7) Set on the timer (**ref. 6 Fig. 12**) the duration of the low speed cycle, as instructed in “6.4 Correct use of the machine” on page 39 (at least 2 minutes).
- 8) Set on the timer (**ref. 7 Fig. 12**) the duration of the high speed cycle.
- 9) Turn the switch (**ref. 4 Fig. 12**) to the right-hand position to rotate the tank clockwise, or to the left-hand position to rotate the tank anticlockwise; the movement can be inverted or stopped (switch position 0) at any time.
- 10) Press the start button (**ref. 1 Fig. 12**) for low speed operation.

When the low speed count expires (**ref. 6 Fig. 12** on page 41) the machine will automatically start the high speed cycle, which lasts for the duration set on the timer (**ref. 7 Fig. 12**).

11) When the set times for both cycles have expired, the tool automatically stops.



Note

**After at least 2 minutes of low speed operation, if the flour in the bowl is well amalgamated with the water and no free powder is visible, you may run the machine manually at high speed by pressing the button (ref. 2 Fig. 12).**

12) Press the button (**ref. 6 Fig. 11** on page 40) to raise the head and disengage the carriage;

13) extract the carriage;

14) use a plastic spatula to apportion the dough in the bowl into rough blocks.

15) Manually remove the blocks of dough from the bowl one at a time.

16) Turn the main switch (**ref. 1 Fig. 11**) to 0.

17) Once again load into the bowl (**ref. 3 Fig. 5** on page 23) the ingredients to be kneaded, while observing the instructions given in “**6.6 Operational limits**” on page 39.

18) Repeat the operating procedure indicated above from point 3) on.

19) At the end of the working day, turn the main switch (**ref. 1 Fig. 11**) to 0.

20) Disconnect the plug from the power socket.

## 6.9 Stop functions

The machine may be stopped:

- **automatically:** when the kneading cycle times set on the timers (**ref. 6 and ref. 7 Fig. 12**) have expired, the tool automatically stops rotating;
- **manually:** press the machine stop button (**ref. 3 Fig. 12**) to stop the machine under normal conditions;
- **in an emergency:** press the mushroom head button (**ref. 5 Fig. 12**) to stop the machine immediately or open the bowl's mobile guard (**ref. 10 Fig. 5**).

The emergency stop devices should only be used when a dangerous situation has arisen or can be prevented; on pressing an emergency button, all moving parts stop immediately.



Prohibited!

**To prolong the lifetime of the electrical contacts on emergency equipment, never stop the machine as an emergency unless it is absolutely necessary.**





**This page intentionally left blank!**

# 7. Maintenance instructions

## 7.1 Safety precautions



The machine shall be serviced and repaired only by qualified staff trained to work on the machine or, where expressly specified in this Manual, by persons employed or authorised by the Manufacturer.



All work must be carried out after making sure that the machine cannot be started up, even accidentally; as such the main switch (ref. 1 Fig. 11 on page 40) should be set to 0 and the plug removed from the mains power socket.



Wear **gloves** at all times.



Wear **safety footwear** at all times.

## 7.2 General warnings



The Manufacturer declines all responsibility for damage caused by incorrect cleaning and/or maintenance of the machine and/or failure to carry out scheduled cleaning/maintenance operations.

## 7.3 Periodic cleaning



All cleaning operations must be carried out after making sure that the machine cannot be started up, even accidentally; as such the main switch (ref. 1 Fig. 11) should be set to 0 and the plug removed from the mains power socket.

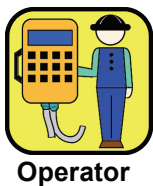

**Daily**, at the end of each day of production, the machine must be left in a perfectly clean and hygienic condition, especially in the following areas:

- parts in contact with food stuffs, such as the interior of the bowl and the kneading tool;
- slots;

- gaps;
- corners;
- areas which are normally not accessible, after having removed the guards mounted with bolts;
- area underneath the machine.

Proceed as follows to clean the machine:

- 1) remove any residue of dough/flour from all parts of the machine, using soft plastic scrapers or soft brushes;
- 2) remove all dirt with a vacuum cleaner;
- 3) clean off any stains with water at ambient temperature.



- **Do not use metal tools to remove residue dough/flour, nor for any other cleaning operations.**
- **Do not use acid or basic solutions to get rid of marks; they are too chemically aggressive and may damage the surfaces of the machine.**
- **Do not direct jets of water at the machine to clean it.**

## 7.4 Routine maintenance

The routine maintenance operations described in this manual are **to be performed by the Customer**.

## 7.4.1 Mechanical maintenance

### 7.4.1.1 Replacing the kneading tool drive belts

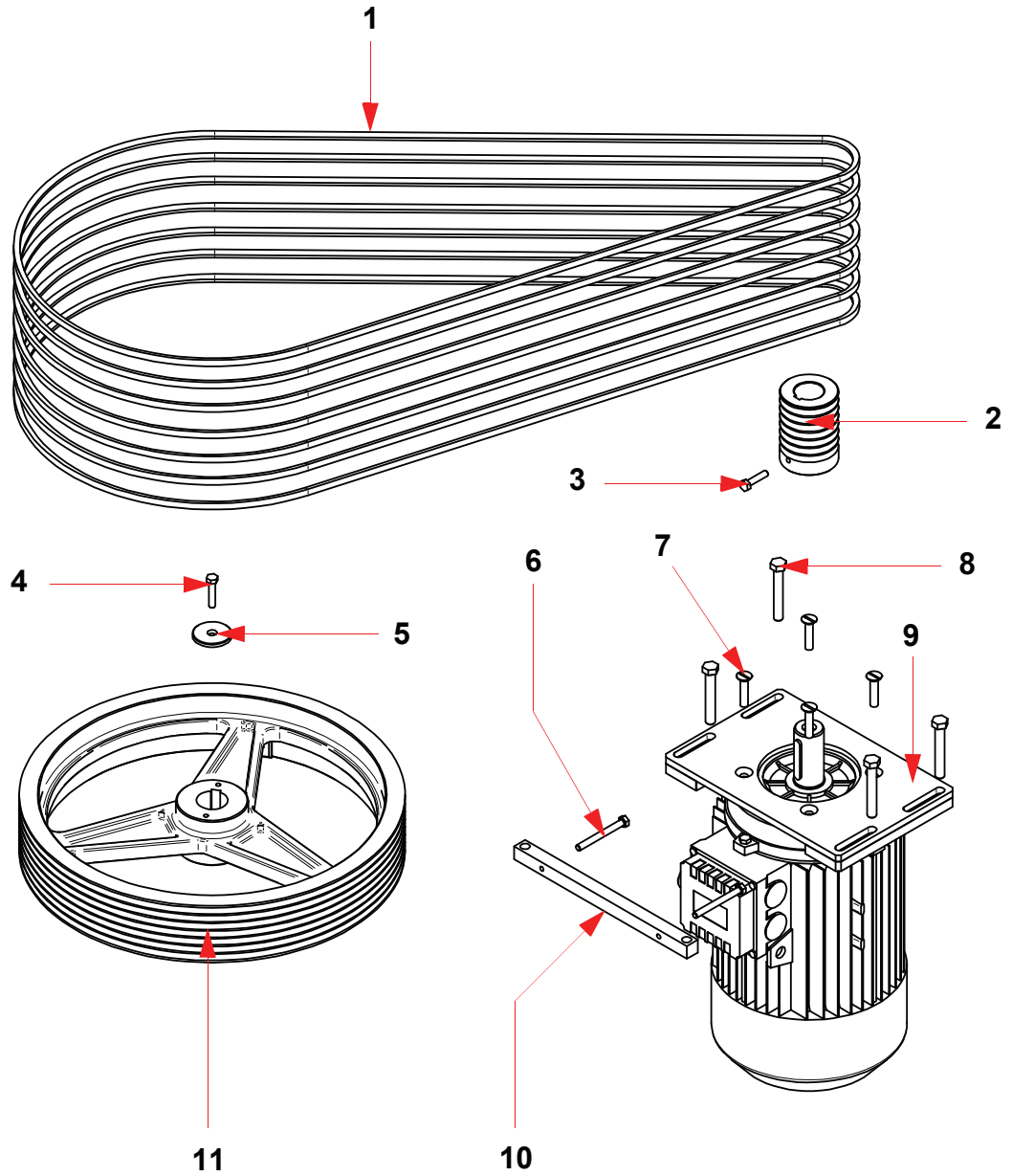

Fig. 13 Kneading tool drive



**For longer service life and better all-round operation, replace all the belts on a given drive section.**

The belts must be replaced as soon as they show signs of wear or damage to the rubber of which they are made.

Proceed as follows:

- 1) remove the fixed top guard (**rif. 5 Fig. 5** on page 23);
- 2) slacken off the 2 bolts (**rif. 6 Fig. 13** on page 47) of the tie rod (**rif. 10 Fig. 13**);
- 3) slacken off the 4 bolts (**rif. 8 Fig. 13**) securing the motor base (**rif. 9 Fig. 13**);
- 4) move the motor base (**rif. 9 Fig. 13**) to slacken off the belts;
- 5) extract any worn belts (**rif. 1 Fig. 13**) and replace them with new ones;
- 6) tighten down the 2 bolts (**rif. 6 Fig. 13**) of the tie rod (**rif. 10 Fig. 13**) until the belts are properly tight;
- 7) tighten down the 4 bolts (**rif. 8 Fig. 13**) securing the motor base;
- 8) restore the fixed top guard (**rif. 5 Fig. 5**).

7.4.1.2 Replacing the bowl drive belts

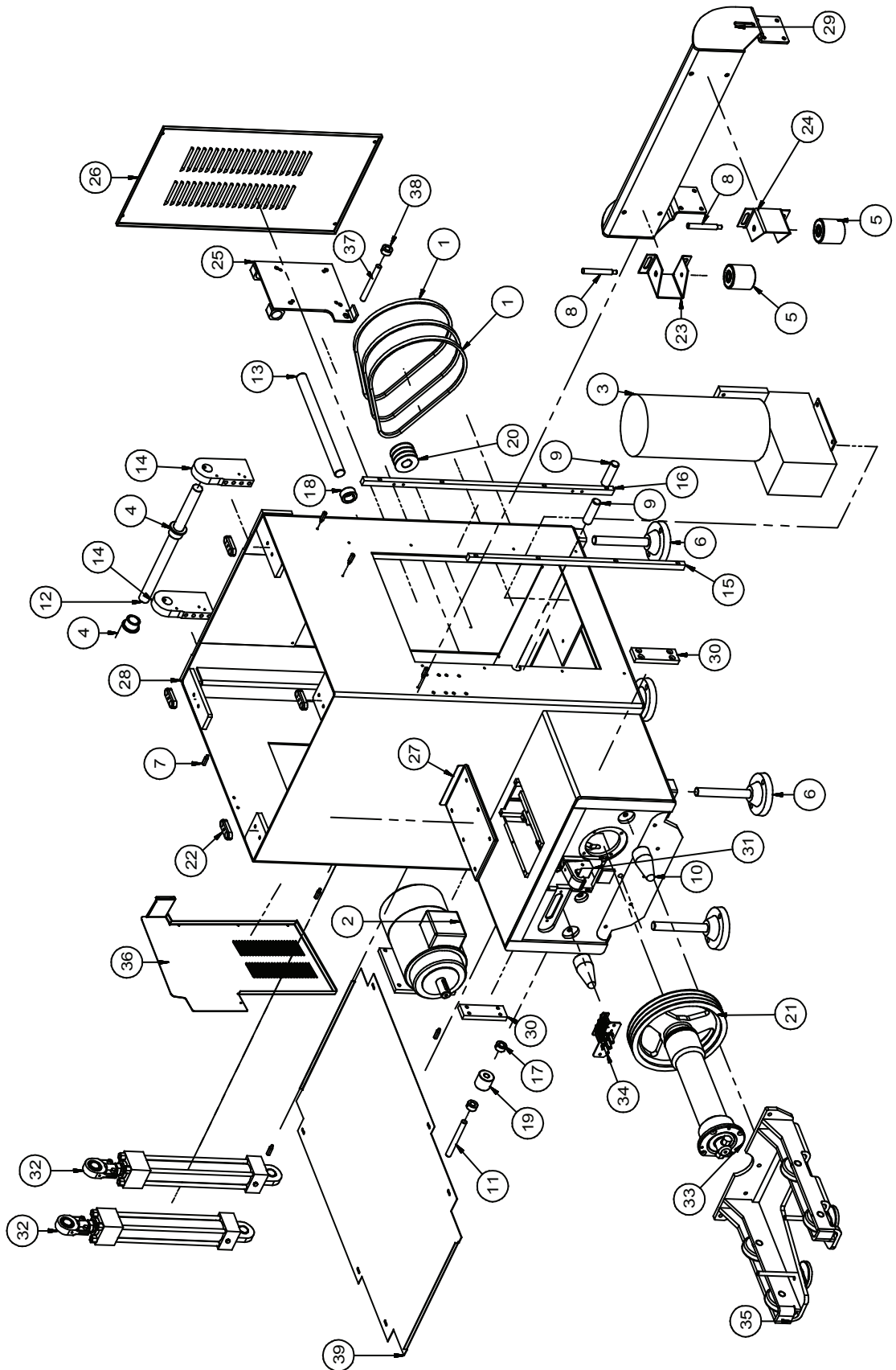

Fig. 14 Bowl drive



**For longer service life and better all-round operation, replace all the belts on a given drive section.**

The belts (**ref. 1 Fig. 14** on page 49) must be replaced as soon as they show signs of wear or damage to the rubber of which they are made.

Proceed as follows:

- 1) Remove the lower side guard (**ref. 4 Fig. 17** on page 65).
- 2) Store the mounting bolts safely so as not to lose them.
- 3) Slacken off the bolt (**ref. 37 Fig. 14**) tensioning the motor base (**ref. 25 Fig. 14**).
- 4) Turn the nut (**ref. 38 Fig. 14**) until the worn belts can be extracted (**ref. 1 Fig. 14**).
- 5) Replace the belts with new ones.
- 6) Turn the nut (**ref. 38 Fig. 14**) in the opposite direction to that of point 3) until the belts are correctly tensioned, see “**7.4.1.3 Tension of belts**” on **page 51**.
- 7) Tighten down the bolt (**ref. 37 Fig. 14**);
- 8) Reinstall the lower side guard, using its mounting bolts.

### 7.4.1.3 Tension of belts



Qualified Technician

Every month, check the tension and wear of the belts.

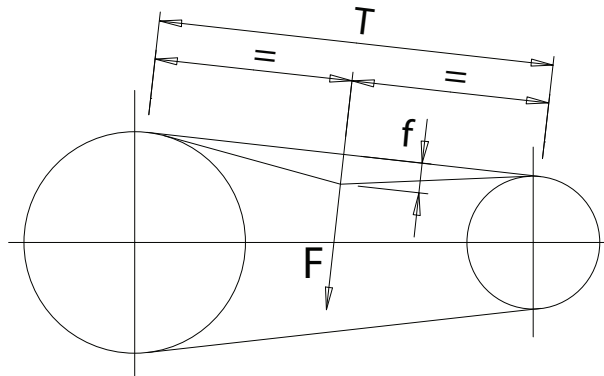

Fig. 15 Tension of belts

To check the tension of the belts, proceed as follows:

- 1) measure the free section **T** (Fig. 15 on page 51);
- 2) for each belt, use a torque wrench at the mid point of **T** to apply a perpendicular force **F** resulting in a displacement **f** of 1.5 mm per 100 mm of **T**;

Example:  $T=1300\text{ mm}$   $f=1300:100 \times 1.5 = 19.5\text{ mm}$

- 3) the resulting force in Newtons must be in the range **x1** to **x2** N (see **Table 3** on page 51, **Table 4**, **Table 5**, **Table 6** and **Table 7** on page 52);
- 4) if **F** is less than **X1** N increase the belt tension, if **F** is more than **X2** N the belt is tighter than necessary and must be slackeden off.

For tensioning and replacement instructions, see “7.4.1.1 Replacing the kneading tool drive belts” on page 47 and “7.4.1.2 Replacing the bowl drive belts” on page 49.

N	Kneading tool		Bowl
	Sprocket motor belts	Pulley sprocket belts	Pulley motor belts
<b>x1</b>	10	7	11
<b>x2</b>	13	10	13

Table 3 EVO 130: belt tension reference values



N	Kneading tool		Bowl
	Sprocket motor belts	Pulley sprocket belts	Pulley motor belts
x1	10	7	11
x2	13	10	13

Table 4 EVO 160: belt tension reference values

N	Kneading tool		Bowl
	Sprocket motor belts	Pulley sprocket belts	Pulley motor belts
x1	10	7	11
x2	13	10	13

Table 5 EVO 200: belt tension reference values

N	Kneading tool		Bowl
	Sprocket motor belts	Pulley sprocket belts	Pulley motor belts
x1	10	7	11
x2	13	10	13

Table 6 EVO 250: belt tension reference values

N	Kneading tool		Bowl
	Sprocket motor belts	Pulley sprocket belts	Pulley motor belts
x1	10	7	11
x2	13	10	13

Table 7 EVO 300: belt tension reference values



The tension of the belts can be checked empirically by pressing on the taut section of the belt and checking that the deviation is approximately the thickness of the belt itself. We recommend using a torque wrench.

## 7.4.2 Electrical maintenance

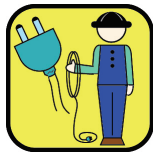

**Electrical Technician**

Maintenance of machine electrical equipment, including the motor, must be performed solely by qualified technical staff.



**Operator**

The operator may only perform the following electrical maintenance:

- 1) resetting a thermal cut-out;
- 2) replacing a fuse.

### 7.4.2.1 Resetting a thermal cut-out

To reset a thermal cut-out, perform the following steps in order:

- 1) turn the main switch (**ref. 1 Fig. 11** on page 40) to 0;
- 2) open the door of the electrical cabinet using the key supplied with the machine;
- 3) identify the thermal cut-out (normally marked QF).
- 4) lightly press the button marked **(I)** if it is sticking out further than the one marked **(O)**;
- 5) wait for 10 seconds;
- 6) if the thermal cut-out does not reset, repeat the operation described in step 5) above.



**Note**

**In the case of a thermal relay, normally marked FR, wait for the device to reset itself automatically (this will vary from 10 seconds to a minute or so).**

**In the case of an inverter, switch off the machine and wait for at least 30 seconds for the device to reset.**



**Prohibited!**

**Do not tamper with the settings of thermal cut-outs.**

### 7.4.2.2 Replacing a fuse

- 1) turn the main switch (**ref. 1 Fig. 11**) to 0;
- 2) open the door of the electrical cabinet using the key supplied with the machine;
- 3) locate the fuse holder;
- 4) remove the fuse;
- 5) replace the fuse with one of the same amperage.

### 7.4.3 Daily maintenance

- Clean the machine carefully, paying special attention to the parts which come into contact with food, such as the inside of the tank and the kneading tools (see also 7.3).  
Never use scrapers or wire brushes for cleaning; use soft plastic materials only.
- Check the efficiency of the accident-prevention devices. (See safety manual Chapter 7.1).

### 7.4.4 Weekly maintenance: Not applicable to this machine

### 7.4.5 Monthly maintenance: Not applicable to this machine

### 7.4.6 Quarterly maintenance

- Check the level of the bowl carriage gear oil and top it up if necessary via the filler hole **ref. 5 Fig. 11** on page 40. The following tables give the amounts and types of oils required to fill the tanks.  
To drain the oil from the bowl carriage tank, first raise the carriage with a fork lift.



			EVO 130 kg	EVO 160 kg	EVO 200 kg	EVO 250 kg	EVO 300 kg
Hydraulic circuit	TERESSO 32	OTE 32	9	9	9	9	9
Carriage	SPARTAN EP 460	BLASIA 460	2	2	2	3	3

Table 8

	Type of hole	EVO 130-160-200		EVO 250-300	
		Ref.	Photo	Ref.	Photo
Carriage	Drain	-	-	-	-
	Filling up	13	5	13	5

Table 9

## 7.5 Reactive maintenance

### 7.5.1 Replacements

#### 7.5.1.1 Replacing the kneading tool motor



**Manufacturer's  
Technician**

The operations described below must only be carried out by qualified technical staff employed or authorised by the Manufacturer.

To replace the kneading tool motor, proceed as follows:

- 1) remove the belts (**ref. 6 and ref. 8 Fig. 13** on page 47) as shown in **"7.4.1.1 Replacing the kneading tool drive belts"** on page 47;
- 2) remove the bolts (**ref. 6 Fig. 13**) the tie (**ref. 10 Fig. 13**) and the bolts base (**ref. 9 Fig. 13**);
- 3) fit an eyebolt with the same male threading into the M12 threaded hole on the motor shaft;
- 4) hook the eyebolt to a lifting device;
- 5) lift the motor, taking care to prevent collisions with other fixed parts of the machine, just enough to facilitate the opening of the terminal block for the disconnection of the electrical wiring;
- 6) remove the cover of the motor terminal block;
- 7) disconnect the electrical wiring from the terminal block;

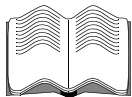

**Warning!**

**Note down the order of connection of the wires (6 for a two-speed motor).**

- 8) support the motor to prevent your fingers being crushed, and lower it slowly to the ground;
- 9) remove the motor base (**ref. 9 Fig. 13**);
- 10) separate the pulley from the motor (**ref. 2 Fig. 13**), by slackening off the grub screw (**ref. 32 Fig. 13**);
- 11) fit the pulley to the shaft of the new motor and secure it with the grub screw and the support and mount removed in the previous step (**ref. 9 Fig. 13**);
- 12) fit the eyebolt into the threaded boring in the new motor;
- 13) lift the assembly with the lifting device mentioned above and lower it through the upper section of the frame;
- 14) reconnect the electrical wires to the terminal block of the new motor.

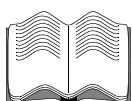

**Warning!**

**Make sure to observe the same order as that used for the old motor. In case of doubt, the electrical documentation attached to this Manual clearly shows the connections.**

- 15) repeat in reverse order all the operations of steps 15 to 1, until the initial configuration has been restored;
- 16) check that the motor runs in the correct direction (see point 3) in “**5.6 First start-up**” on page 34);
- 17) if it does not, swap two phases for each triple on the motor terminal block, see point 4) in “**5.6 First start-up**” on page 34);
- 18) tension the belts (ref. 1 Fig. 13 on page 47), see “**7.4.1.3 Tension of belts**” on page 51.

### 7.5.1.2 Replacing the bowl motor



**Manufacturer's  
Technician**

The operations described below must only be carried out by qualified technical staff employed or authorised by the Manufacturer.

To replace the bowl motor, proceed as follows:

- 1) switch off the electric power supply (see the warning in 7.1 on page 45);
- 2) remove the rear guard (ref. 26 Fig. 14 on page 49);
- 3) remove the left side guard (ref. 36 Fig. 14).
- 4) remove the belts (ref. 1 Fig. 14), see “**7.4.1.2 Replacing the bowl drive belts**” on page 49;
- 5) slacken off the stud bolt securing the two spacers (ref. 18 Fig. 14);
- 6) extract the motor (ref. 2 Fig. 14) and mount (ref. 25 Fig. 14) taking care not to let the two spacers fall to the ground (ref. 18 Fig. 14);
- 7) support the motor to prevent your fingers being crushed, and lower it slowly to the ground;
- 8) slacken off the bolts securing the motor (ref. 2 Fig. 14) to its mount (ref. 25 Fig. 14);
- 9) remove the cover of the motor terminal block;



**Warning!**

**Note the exact order of electrical connections.**

- 10) disconnect the electrical wiring from the terminal block;
- 11) reconnect the electrical wires to the terminal block of the new motor;



**Warning!**

**Make sure to observe the same order as that used for the old motor. In case of doubt, the electrical documentation attached to this Manual clearly shows the connections.**

- 12) refit the cover of the motor terminal block;
- 13) repeat in reverse order all the operations of steps 10 to 1, until the initial configuration has been restored;
- 14) tension the belts (ref. 1 Fig. 14 on page 49), see “**7.4.1.3 Tension of belts**” on page 51.

### 7.5.1.3 Replacing the motor (ref. 3 Fig. 14) of the hydraulic unit



**Manufacturer's  
Technician**

The operations described below must only be carried out by qualified technical staff employed or authorised by the Manufacturer.

- 1) Switch off the electric power supply (see the warning in 7.1 on page 45);
- 2) remove the rear guard (**ref. 26 Fig. 14**);
- 3) remove the terminal block cover;
- 4) disconnect the electrical cables from the terminal block;

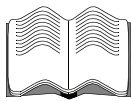

**Warning!**

**Note the exact order of the electrical connections.**

- 5) remove the four bolts securing the motor;
- 6) supporting the motor carefully to prevent it crushing your limbs, lower it slowly to the ground;
- 7) separate the coupling from the motor, loosening the retaining bolt and the flange;
- 8) fit the coupling onto the new motor shaft and secure in position with the locking bolt and flange;
- 9) replace the motor in its seat;
- 10) tighten down the four bolts securing the motor;
- 11) reconnect the electrical wires to the terminal block of the new motor.

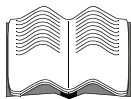

**Warning!**

**Make sure to observe the same order as that used for the old motor. In case of doubt, the electrical documentation attached to this Manual clearly shows the connections.**

- 12) Switch on the electrical power supply;
- 13) check that the motor is running in the right direction by operating the head up buttons: the head must raise, if it does not, swap the connections (see par. 5.6 on page 34);
- 14) refit the rear guard (**ref. 26 Fig. 14**);

### 7.5.1.4 Replacing the kneading tool



**Manufacturer's  
Technician**

The operations described below must only be carried out by qualified technical staff employed or authorised by the Manufacturer.

To replace the kneading tool (**ref. 4 Fig. 6** on page 23) proceed as follows:

- 1) Switch off the electric power supply (see the warning in **7.1** on page 45);
- 2) support the kneading tool, taking care to prevent it damaging the machine or crushing your limbs;
- 3) remove the three bolts securing the kneading tool to the drive shaft;
- 4) place the tool gently on the ground;
- 5) fit the new tool;
- 6) tighten down the three bolts securing the kneading tool to the drive shaft.

## 7.6 Troubleshooting

Fault type	Probable cause	Possible remedy
The machine or one of its parts does not start.	<ul style="list-style-type: none"> <li>● Thermal cut-out tripped.</li> </ul>	<ul style="list-style-type: none"> <li>● Reset. See “7.4.2 Electrical maintenance” on page 53</li> </ul>
	<ul style="list-style-type: none"> <li>● Fuse blown.</li> </ul>	<ul style="list-style-type: none"> <li>● Replace fuse. See “7.4.2 Electrical maintenance” on page 53</li> </ul>
	<ul style="list-style-type: none"> <li>● Short circuit or grounding of motor phase.</li> </ul>	<ul style="list-style-type: none"> <li>● Replace motor. See “7.5.1.1 Replacing the kneading tool motor” on page 55 and “7.5.1.2 Replacing the bowl motor” on page 56</li> </ul>
	<ul style="list-style-type: none"> <li>● Emergency shut-down (red mushroom-head button) ON.</li> </ul>	<ul style="list-style-type: none"> <li>● Reset by rotating clockwise.</li> </ul>
	<ul style="list-style-type: none"> <li>● Mobile bowl guard raised.</li> </ul>	<ul style="list-style-type: none"> <li>● Lower the guard.</li> </ul>
When running, the tank wobbles.	<ul style="list-style-type: none"> <li>● Too much slack between guide rollers and bowl.</li> </ul>	<ul style="list-style-type: none"> <li>● Adjust the roller mounts (<b>ref. 23 and ref. 24 Fig. 14</b> on page 49) so that each roller contacts the bowl at the point at which it is closest to the roller when turning. <b>Reactive maintenance</b></li> </ul>
	<ul style="list-style-type: none"> <li>● Belt too loose.</li> </ul>	<ul style="list-style-type: none"> <li>● Tension belt. See “7.4.1.3 Tension of belts” on page 51</li> </ul>
The tool tends to stick	<ul style="list-style-type: none"> <li>● Mixture too dense or quantity too great.</li> </ul>	<ul style="list-style-type: none"> <li>● Add water or decrease the mass of ingredients.</li> </ul>

Table 10 Troubleshooting



**This page intentionally left blank!**

## 8. Dismantling and scrapping



Qualified  
Technician

The machine must be dismantled and scrapped by qualified staff.  
If not available, contact the Manufacturer.

- 1) Remove the machine plug from the mains power socket.
- 2) Separate parts according to their component materials:
  - electrical parts in polymer should be sent for controlled disposal;
  - transmission oil (if present) should be consigned to an authorised spent oil disposal consortium;
  - plastic parts (if present) should be disposed of or recycled as such;
  - the rest of the machine is made of ferrous materials which must be recycled as such.



Note

**All materials must be disposed of as provided by established legislation in the country of use.**

## 9. Attached documentation

The following documentation is enclosed with this Manual:

- Declaration of conformity
- Power circuit wiring diagrams
- Control circuit wiring diagrams

## 10. Reference manuals for third party components

This Manual contains all instructions provided by other Manufacturers regarding the machine components they have supplied. The manuals for third party components are therefore not supplied separately.





**This page intentionally left blank!**

# 11. Safety signs installed on the machine



**Fig. 16 Position of safety signs**

The machine is equipped with stickers bearing danger and warning notices. These stickers do not replace the safety instructions given in the Manual, nor may they be considered the sole precautions to be observed. They are to be considered as an aid to the machine's operators and inspectors, inasmuch as they indicate information and prescriptions regarding the safe use of the machine for the parts to which they are attached.



**Do not remove, damage or render illegible the machine's safety signs.**

See **Fig. 16** on page 63 for the positions of the stickers on the machine.  
In particular:



**Supervisor**

The Supervisor must check the condition of the colours and texts of the safety signs posted on the machine.  
At the first sign of damage to them, he must replace them with new ones supplied by the Manufacturer, as described in “**1.6.3 Spare parts**” on page 11.



**Hazard of entrapment/entrapment of the hands (ref. 1 Fig. 16).**  
Yellow background, black symbol and border.

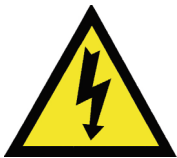

**Electrocution hazard (ref. 2 Fig. 16).**  
Yellow background, black symbol and border.

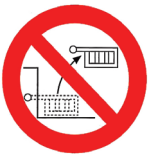

**Do not remove the guards (ref. 3 Fig. 16).**  
White background, black symbol and red border.

**SHUT OFF POWER TO THE MACHINE BEFORE REMOVING THE GUARDS.  
REPLACE AND SECURE ALL GUARDS BEFORE PLUGGING IN AND SWITCHING ON THE MACHINE.**

**(ref. 4 Fig. 16).**  
Blue background, white text and border.

**DO NOT CLEAN, OIL OR GREASE BY HAND ANY PARTS OR ASSEMBLIES WHILE THE MACHINE IS RUNNING.**

**(ref. 5 Fig. 16).**  
Red background, white text and border.

**DO NOT ACCESS THE AREA BETWEEN THE FRAME AND THE BOWL WITH YOUR HANDS WHILE THE MACHINE IS RUNNING.**

**(ref. 6 Fig. 16).**  
Yellow background, black text and border.

# 12. List of components and spare parts

For the list of spare parts, refer to the parts subject to wear indicated in negative in the following tables.

## 12.1 List 1

Ref.	Fig.	Description	EVO 130	EVO 160	EVO 200	EVO 250	EVO 300
1	17	Electrical cabinet	-	-	-	-	-
2	17	Rear lower guard	32901026	32900991	32900991	32900991	32900991
3	17	RH guard	32930890	32930883	32930883	32930876	32930876
4	17	LH guard	32930891	32930881	32930881	32930877	32930877
5	17	Push-button panel guard	32940623	32940619	32940619	32940629	32940629
6	17	<b>Safety guard</b>	<b>33260134</b>	<b>33260135</b>	<b>33260135</b>	<b>33260136</b>	<b>33260136</b>
7	17	Bowl carriage assembly	39012199	39012200	39012201	39012202	39012203
8	17	Head assembly	-	-	-	-	-
9	17	Base assembly	39012215	39012213	39012213	39012209	39012209

Table 11 Machine components:ref. Fig. 17

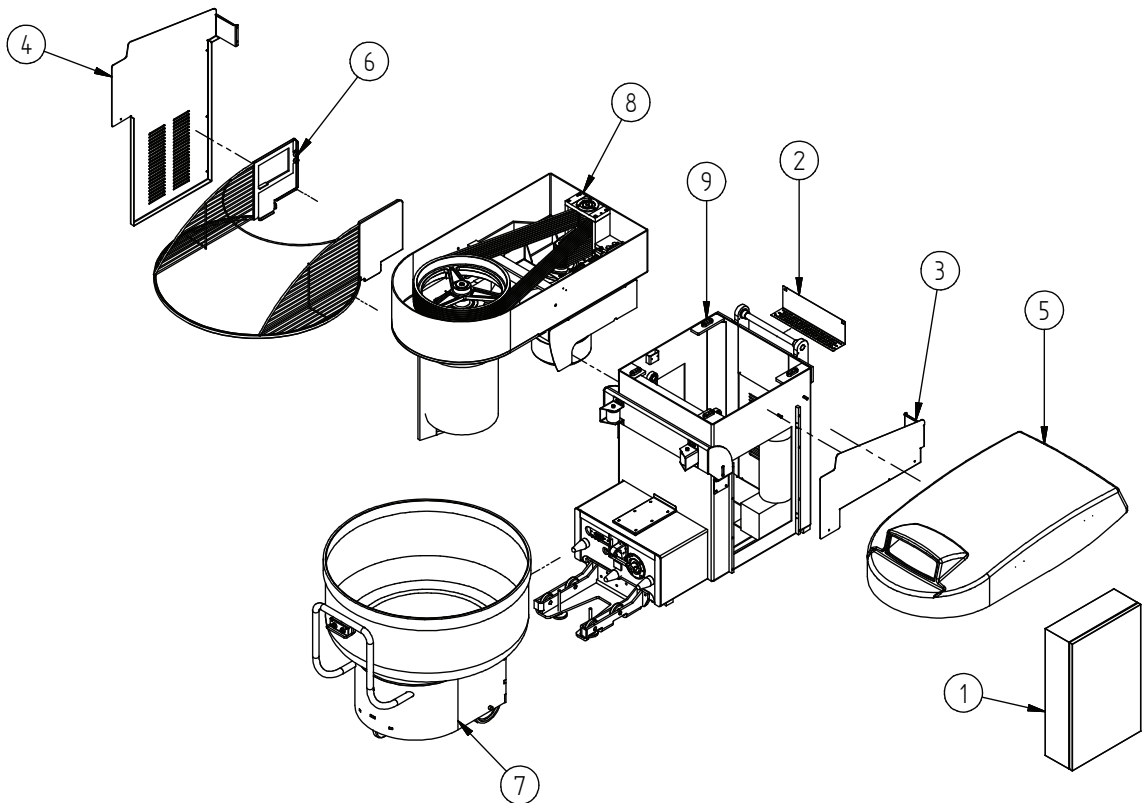

Fig. 17 Machine components: table 11

## 12.2 List 2

Ref.	Fig.	Description	EVO 130	EVO 160	EVO 200	EVO 250	EVO 300
1	18	Belts	24055181	24055182	24055182	24055182	24055182
2	18	Motor	22000180	22000180	22000180	22000226	22000226
3	18	Filling up	24000040	24000040	24000040	24000040	24000040
4	18	Bushing	24015113	24015113	24015113	24015113	24015113
5	18	Rollers with bearing	24065016	24065017	24065017	24065017	24065017
6	18	Foot	24070024	24070024	24070024	24070024	24070024
7	18	Spacer	26001704	26001704	26001704	26001704	26001704
8	18	Bowl wheel pin	30010526	30020570	30020570	30020570	30020570
9	18	Hydraulic piston pin	30020851	30020851	30020851	30020851	30020851
10	18	Centring pin	30020886	30020886	30020886	30020886	30020886
11	18	Attachment adjuster pin	30020884	30020884	30020884	30020884	30020884
12	18	Hinge pin	30050894	30050894	30050894	30050894	30050894
13	18	Motor plate pin	30050908	30050908	30050908	30050908	30050908
14	18	Hinge plate	30220664	30220664	30220664	30220664	30220664
15	18	Electrical cabinet spacer plate	30260386	30260386	30260386	30260380	30260380
16	18	Electrical cabinet spacer plate	30260387	30260387	30260387	30260387	30260387
17	18	Motor shaft retainer	30610088	30610088	30610088	30610088	30610088
18	18	Spacer	30611071	30611071	30611071	30611071	30611071
19	18	Spacer	30611098	30611098	30611098	30611098	30611098
20	18	Pulley	31210055	31210055	31210055	31210056	31210056
21	18	Pulley	31240018	31240018	31240018	31240019	31240019
22	18	Block	32210209	32210209	32210209	32210209	32210209
23	18	LH wheel mount	32420759	32421001	32421001	32421001	32421001
24	18	RH wheel mount	32420760	32421000	32421000	32421000	32421000
25	18	Motor support	32440437	32440437	32440437	32440437	32440437
26	18	Rear guard	32910726	39910726	39910726	39910726	39910726
27	18	Cover panel	32901033	32901018	32901018	32901003	32901003
28	18	Pedestal	33650141	33650142	33650142	33650144	33650144
29	18	Front wheel frame	33650152	33730127	33730127	33730126	33730126
30	18	Rim	35100277	35100277	35100277	35100277	35100277
31	18	Cylinder shaft	38850841	38850841	38850841	38850841	38850841
32	18	Cylinder shaft + ball joint	38850839	38850858	38850858	38850858	38850858
33	18	Bowl drive assembly	38850863	38850863	38850863	38850863	38850863
34	18	Pin contact	39012155	39012155	39012155	39012155	39012155
35	18	Tip	39012193	39012193	39012193	39012193	39012193
36	18	LH guard	32930891	32930881	32930881	32930877	32930877
37	18	Threaded rod	-	-	-	-	-
38	18	Nut	26000480	26000480	26000480	26000480	26000480
39	18	Lower guard	32950419	32950418	32950418	32950416	32950416

Table 12 Machine components: ref. Fig. 18

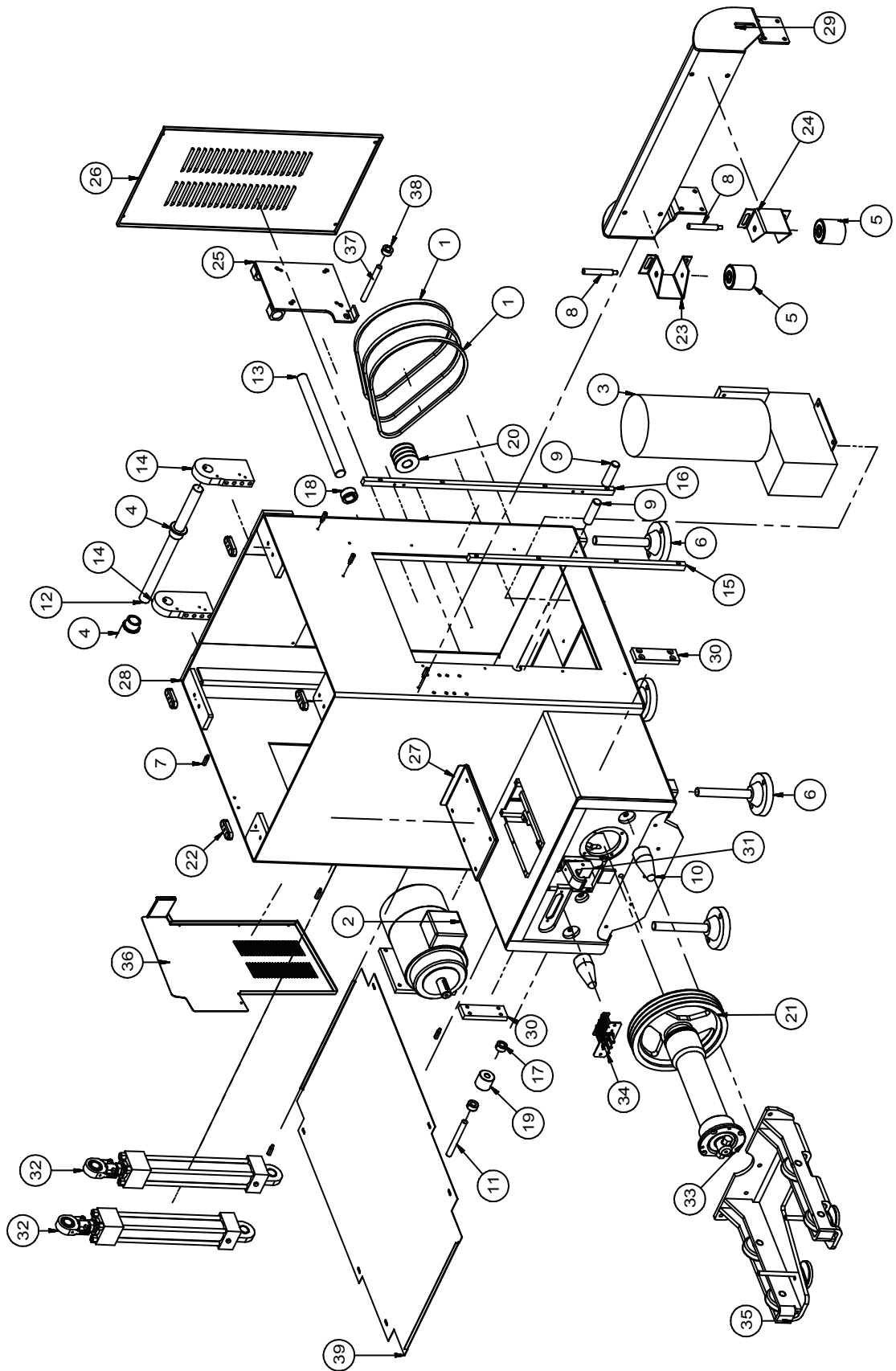

Fig. 18 Machine components: table 12

### 12.3 List 3

Ref.	Fig.	Description	EVO 130	EVO 160	EVO 200	EVO 250	EVO 300
1	19	Cylinder	24002036	24002036	24002036	24002036	24002036
2	19	90° union	24024267	24024267	24024267	24024267	24024267
3	19	Pin for hydraulic piston	30020852	30020852	30020852	30020852	30020852
4	19	Inner spacer	30611055	30611055	30611055	30611055	30611055
5	19	Cylinder hook	32620013	32620013	32620013	32620013	32620013

Table 13 Machine components: ref. Fig. 19

### 12.4 List 4

Ref.	Fig.	Description	EVO 130	EVO 160	EVO 200	EVO 250	EVO 300
1	20	Cylinder	24002037	24002039	24002039	24002039	24002039
2	20	Ball joint	24030041	24030041	24030041	24030041	24030041

Table 14 Machine components: ref. Fig. 20

### 12.5 List 5

Ref.	Fig.	Description	EVO 130	EVO 160	EVO 200	EVO 250	EVO 300
1	21	Hex bolt M6 x 25	26001020	26001020	26001020	26001020	26001020
2	21	Bearing	24006148	24006148	24006148	24006148	24006148
3	21	Bearing	24006160	24006160	24006160	24006160	24006160
4	21	E40 circlip	26000564	26000564	26000564	26000564	26000564
5	21	Transmission clutch pin	30010152	30010152	30010152	30010152	30010152
6	21	Assembly connecting shaft	30050906	30050906	30050906	30050906	30050906
7	21	Spacer	30610285	30610285	30610285	30610285	30610285
8	21	Connecting shaft sleeve	31020227	31020227	31020227	31020227	31020227
9	21	Transmission shaft cover	31020228	31020228	31020228	31020228	31020228
10	21	Bowl pulley	31240018	31240018	31240018	31240019	31240019
11	21	Support	33440069	33440069	33440069	33440069	33440069

Table 15 Machine components: ref. Fig. 21

### 12.6 List 6

Ref.	Fig.	Description	EVO 130	EVO 160	EVO 200	EVO 250	EVO 300
1	22	Pin	30010866	30010866	30010866	30010866	30010866
2	22	Contact plate	30220670	30220670	30220670	30220670	30220670
3	22	Pin bushing	30600601	30600601	30600601	30600601	30600601

Table 16 Machine components: ref. Fig. 22

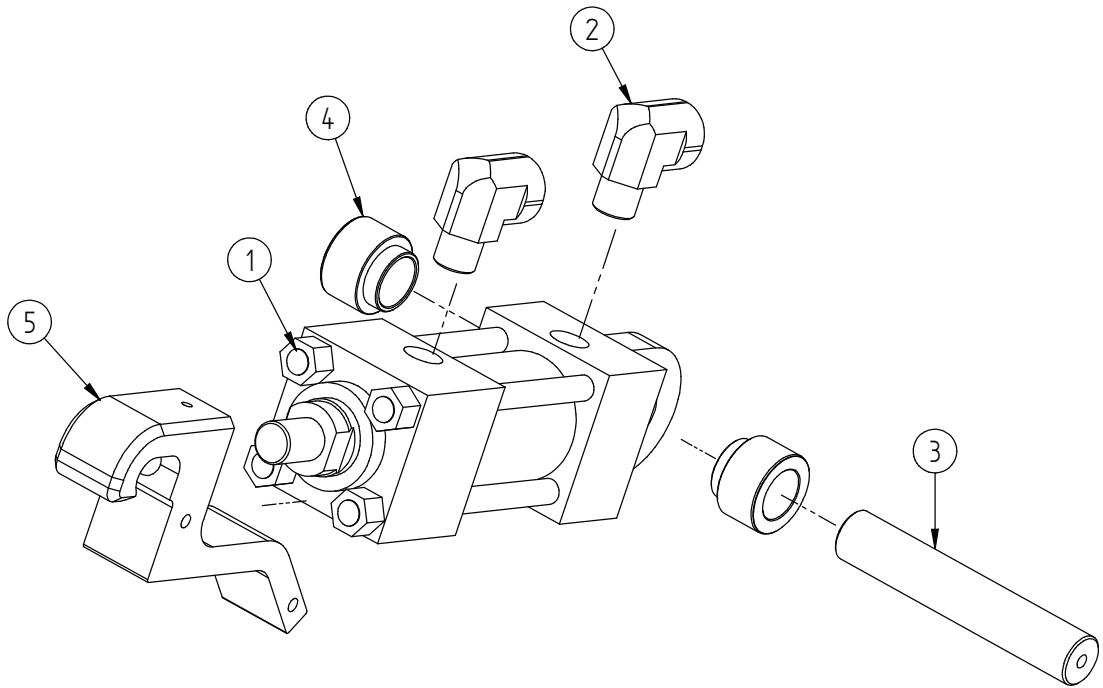

**Fig. 19 Machine components: table 13**

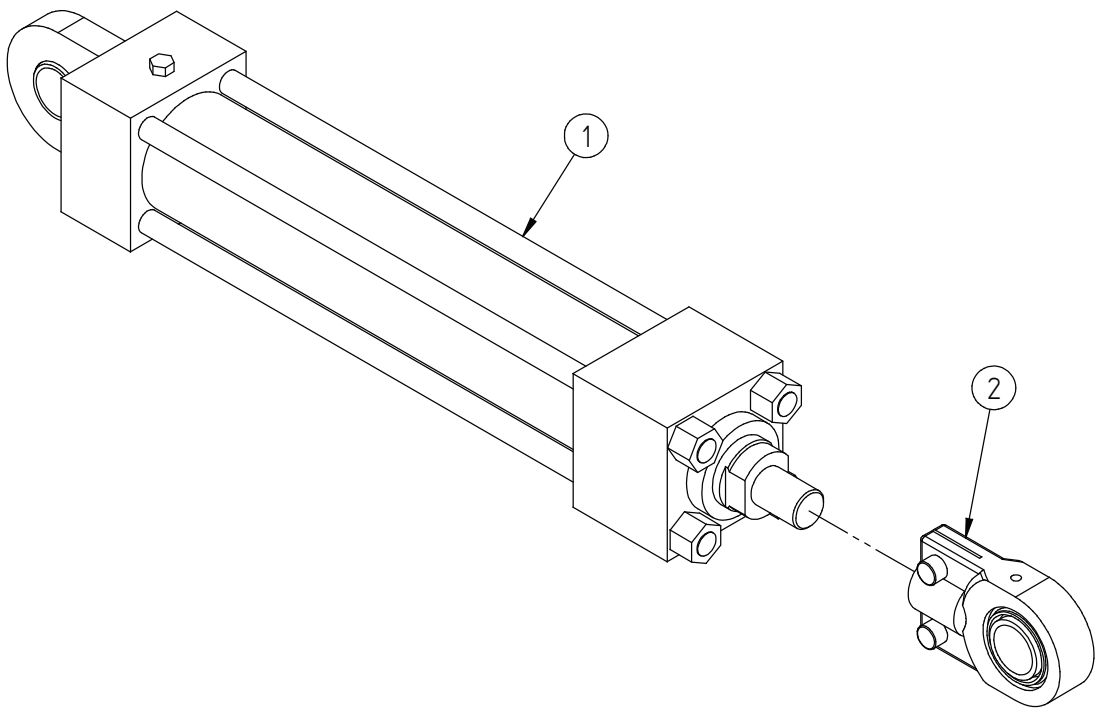

**Fig. 20 Machine components: table 14**

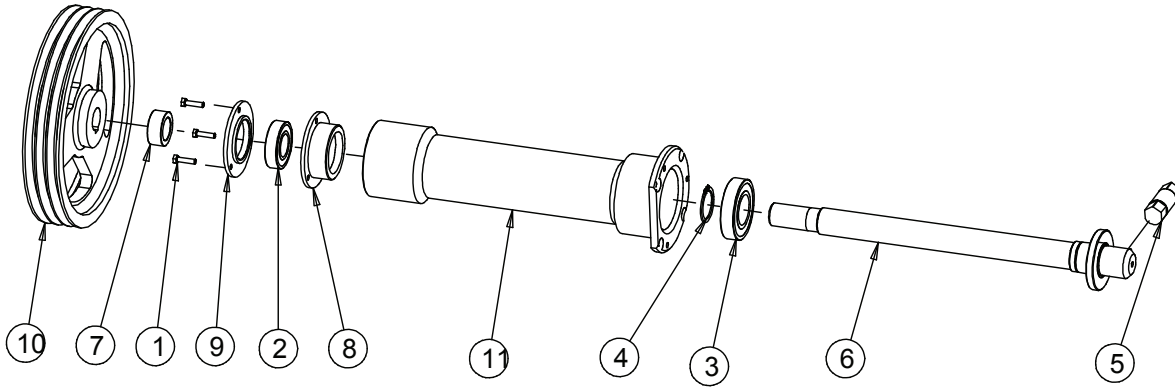

Fig. 21 Machine components: table 15

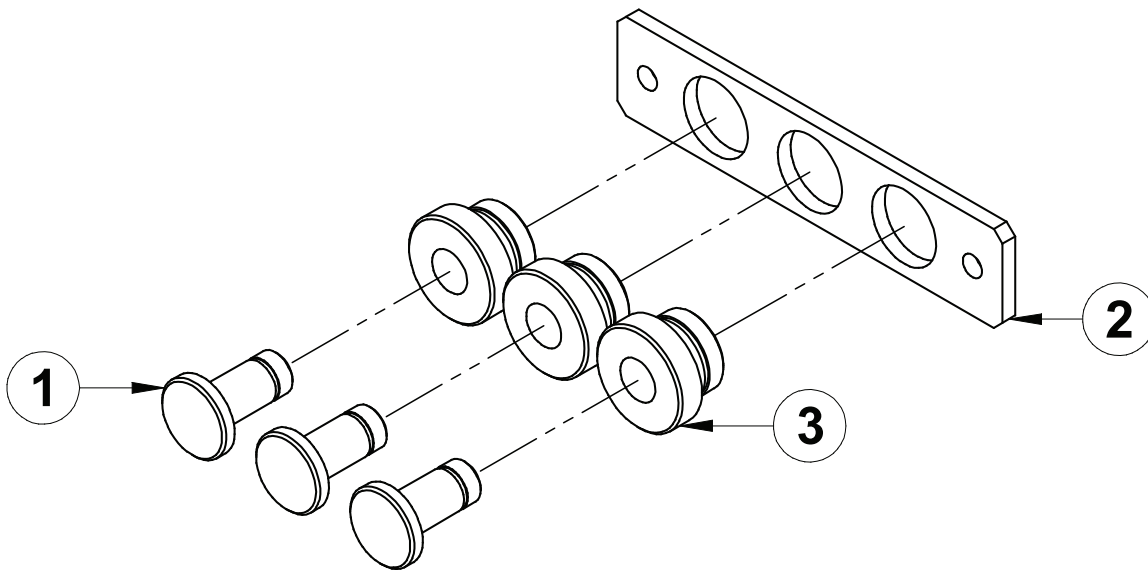

Fig. 22 Machine components: table 16

## 12.7 List 7

Ref.	Fig.	Description	EVO 130	EVO 160	EVO 200	EVO 250	EVO 300
1	23	Fifth wheel	24024264	24024264	24024264	24024264	24024264
2	23	Foot	24070039	24070039	24070039	24070039	24070039
3	23	Pin	30010858	30010858	30010858	30010858	30010858
4	23	Wheel DM 82	31810019	31810019	31810019	31810019	31810019
5	23	Tip	33110384	33110384	33110384	33110384	33110384

Table 17 Machine components: ref. Fig. 23

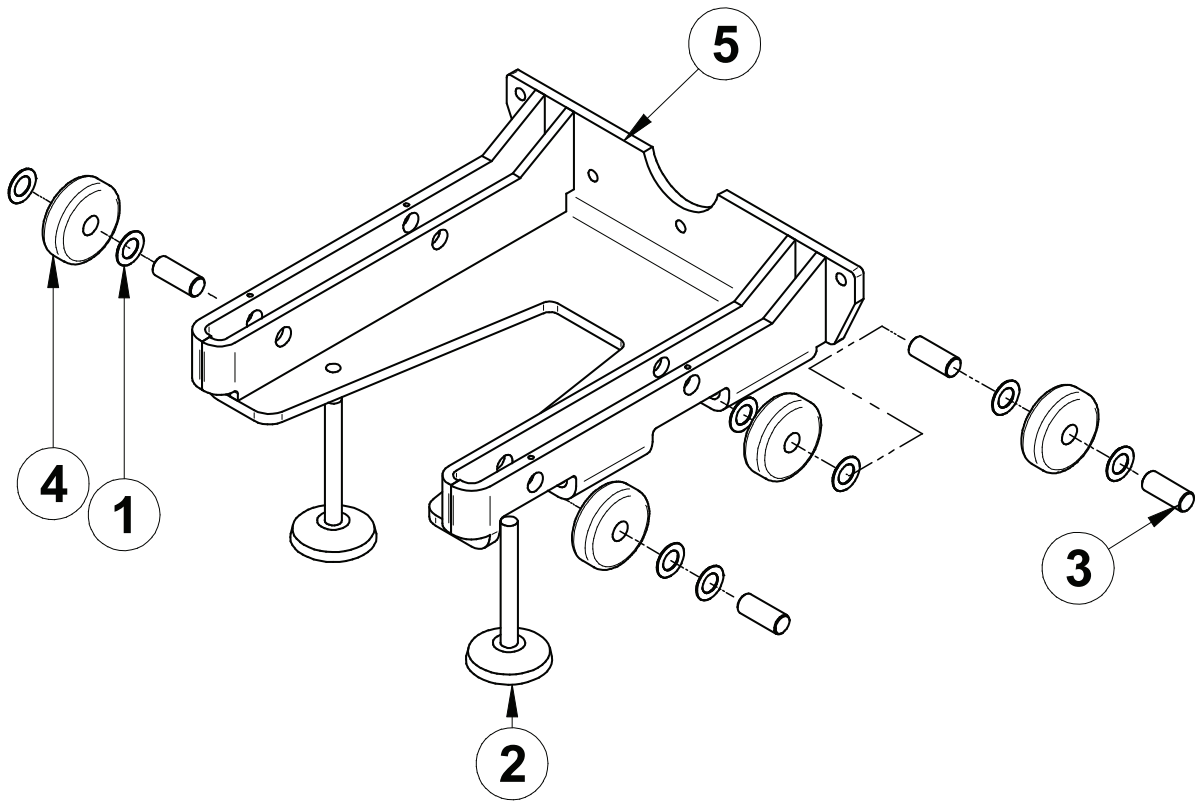

Fig. 23 Machine components: table 17

## 12.8 List 8

Ref.	Fig.	Description	EVO 130	EVO 160	EVO 200	EVO 250	EVO 300
1	24	Spiral kneading tool pulley	31260056	31270024	31270024	31280004	31280004
2	24	Spiral kneading tool	33930123	33930069	33930069	33930085	33930085
3	24	<b>Motor</b>	<b>22000808</b>	<b>22000964</b>	<b>22000964</b>	<b>22000360</b>	<b>22000360</b>
4	24	<b>Oblique bearing</b>	<b>24006333</b>	<b>24006336</b>	<b>24006336</b>	<b>24006341</b>	<b>24006341</b>
5	24	<b>Rig. rad. bearing</b>	<b>24006335</b>	<b>24006337</b>	<b>24006337</b>	<b>24006343</b>	<b>24006343</b>
6	24	Spacer	30620575	30620559	36620559	30620560	30620560
7	24	Spiral kneading tool shaft	30030383	30030383	30030383	30040737	30040737
8	24	Spacer	30611069				
9	24	Spiral kneading tool motor mount	32440496	32440495	32440495	32440495	32440495
10	24	Tie rod	30240147	30240234	30240234	30240234	30240234
11	24	Cover panel	32901047			32901004	32901004
12	24	Under head guard	32940621	32940620	32940620	32940607	32940607
13	24	Lower head guard	32940636	32940618	32940618	32940608	32940608
14	24	Shaft protection	31020191	33200255	33200255	33200257	33200257
15	24	Head	33650202	33650195	33650195	33650146	33650146
16	24	Column	34050014	34070006	34070006	34070004	34070004
17	24	Motor pulley 80/160 rpm	31210301	31210300	31210300	31220125	31220125

Table 18 Machine components: ref. Fig. 24

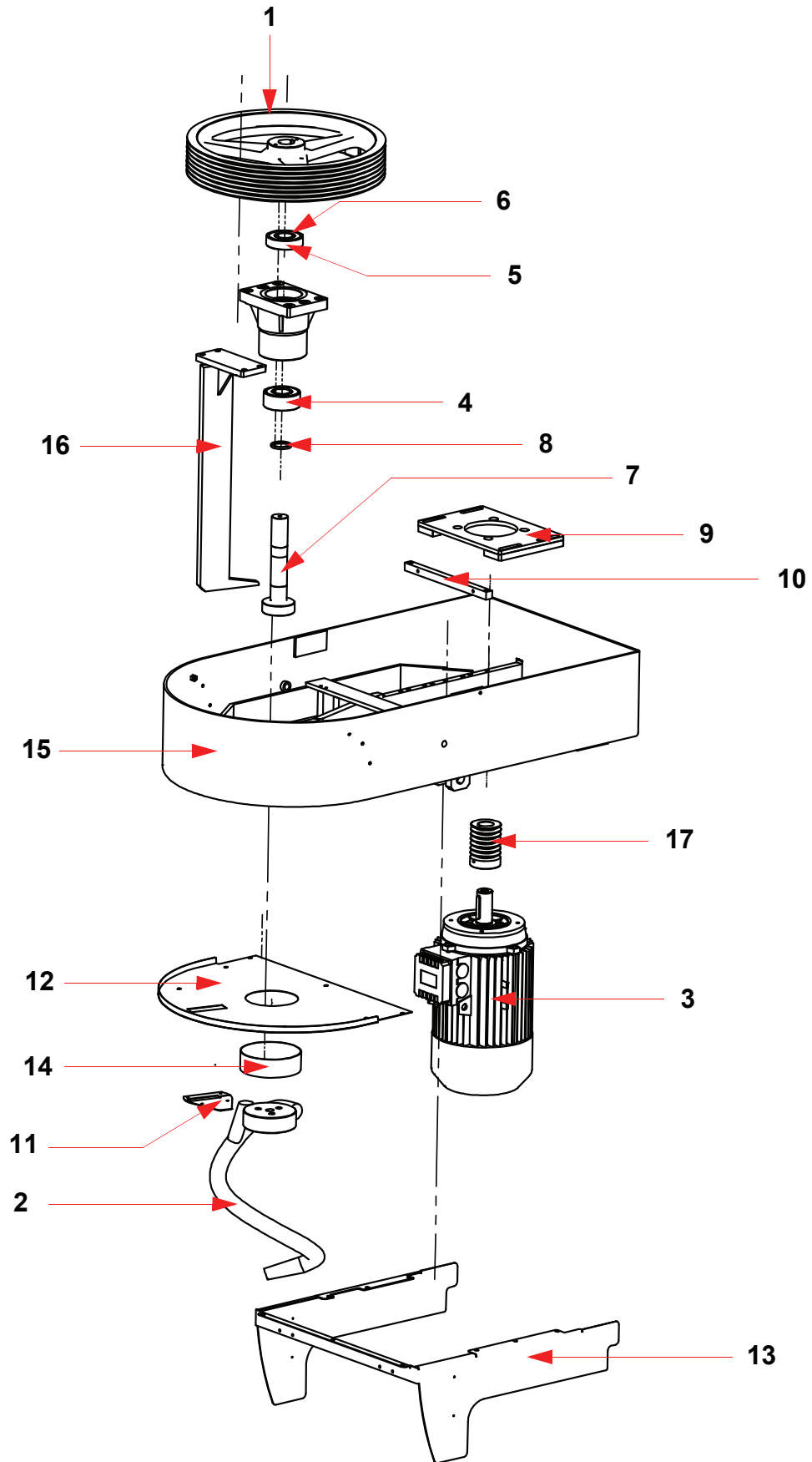

Fig. 24 Machine components: table 18

## 12.9 List 9

Ref.	Fig.	Description	EVO 130	EVO 160	EVO 200	EVO 250	EVO 300
1	25	Belt	24055334	24055291	24055291	24055317	24055317
2	25	Motor pulley 80/160 rpm	31210301	31210300	31210300	31220125	31220125
3	25	Dowel	30620575			30620408	30620408
4	25	Spiral kneading tool motor mount	32440496	32440495	32440495	32440495	32440495
5	25	Tie rod	30240147	30240234	30240234	30240234	30240234
6	25	Spiral kneading tool pulley	31260056	31270024	31270024	31280004	31280004

Table 19 Machine components: ref. Fig. 25

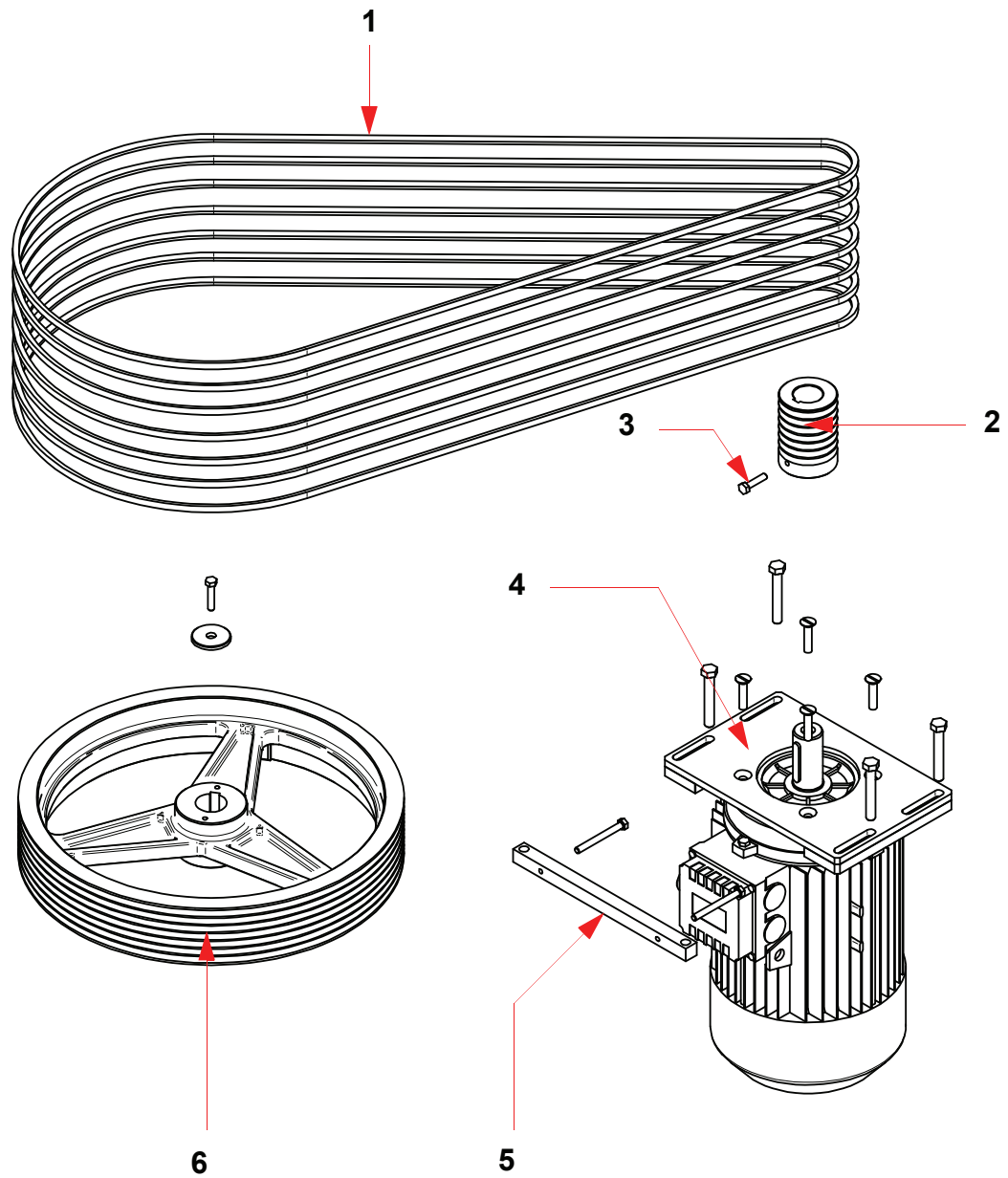

Fig. 25 Machine components: table 19

## 12.10 List 10

Ref.	Fig.	Description	EVO 130	EVO 160	EVO 200	EVO 250	EVO 300
1	26	Bowl	33840085	33840097	33840098	33850071	33850072
2	26	Carriage	39012198	39012198	39012198	39012198	39012198

Table 20 Machine components: ref. Fig. 26

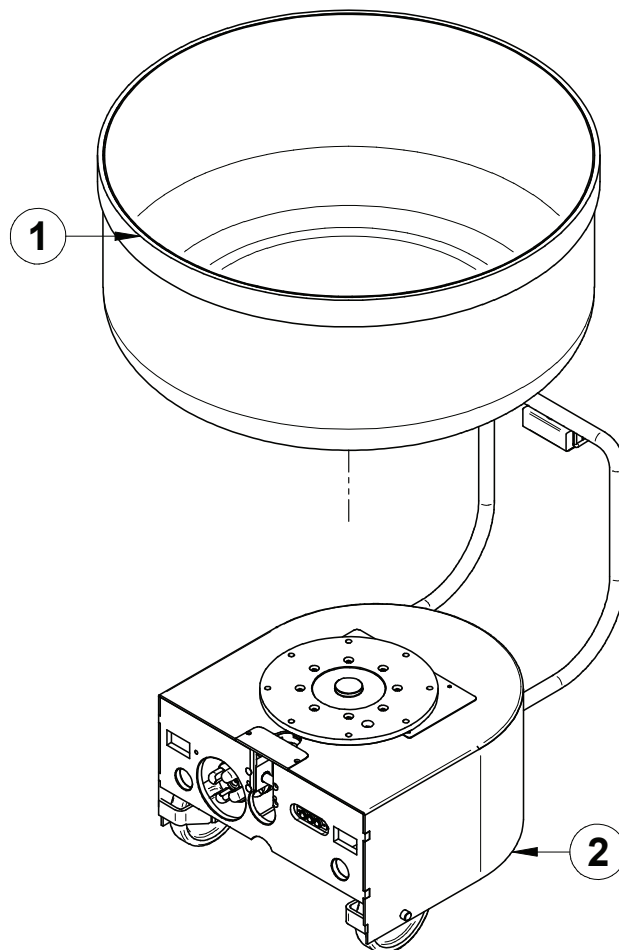

Fig. 26 Machine components: table 20

### 12.11 List 11

Ref.	Fig.	Description	EVO 130	EVO 160	EVO 200	EVO 250	EVO 300
1	27	Push-button	20043152	20043152	20043152	20043152	20043152
2	27	Wheel with bearing	24065014	24065014	24065014	24065014	24065014
3	27	Rotary mount	24070051	24070051	24070051	24070051	24070051
4	27	Pin	30010153	30010153	30010153	30010153	30010153
5	27	Wheel holder pin	30010859	30010859	30010859	30010859	30010859
6	27	Plate	30200075	30200075	30200075	30200075	30200075
7	27	Tank holder flange	30840067	30840067	30840067	30840067	30840067
8	27	Trolley handle	32070006	32070006	32070006	32070006	32070006
9	27	Plate	32220692	32220692	32220692	32220692	32220692
10	27	Push mounting plate	32901008	32901008	32901008	32901008	32901008
11	27	Trolley protection	32910738	32910738	32910738	32910738	32910738
12	27	Trolley	33640118	33640118	33640118	33640118	33640118
13	27	Reducer gear assembly	38850855	38850855	38850855	38850855	38850855
14	27	Pin contact	39012154	39012154	39012154	39012154	39012154

Table 21 Machine components: ref. Fig. 27

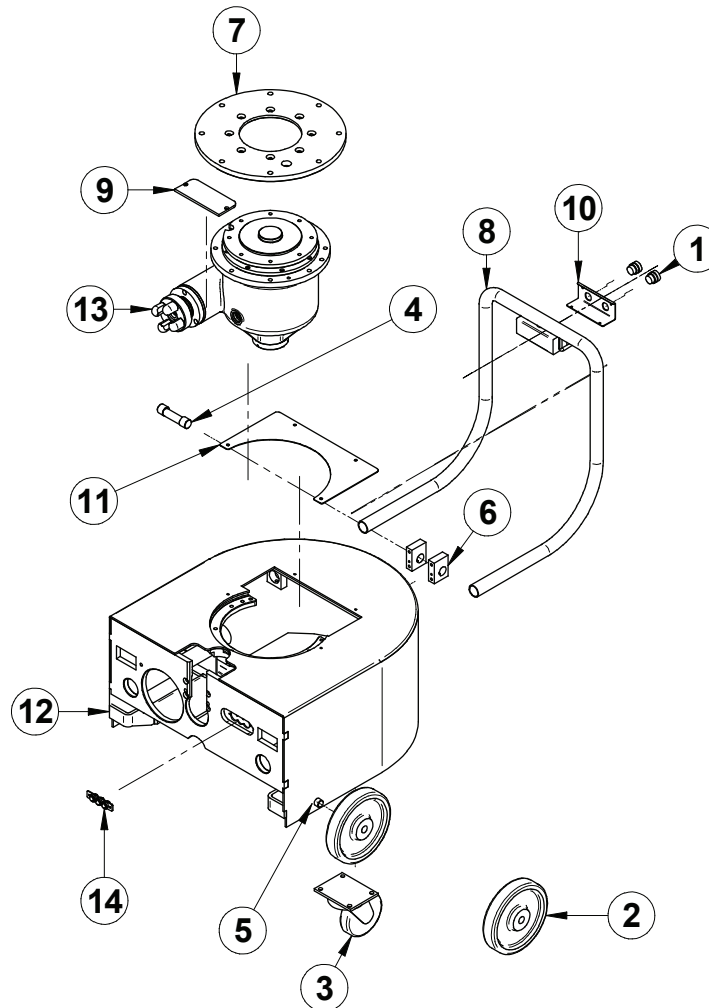

Fig. 27 Machine components: table 21

## 12.12 List 12

Ref.	Fig.	Description	EVO 130	EVO 160	EVO 200	EVO 250	EVO 300
1	28	Flanged shaft	30840058	30840058	30840058	30840058	30840058
2	28	Bearing	24006047	24006047	24006047	24006047	24006047
3	28	Bearing	24006088	24006088	24006088	24006088	24006088
4	28	Bearing	24006148	24006148	24006148	24006148	24006148
5	28	Bearing	24006197	24006197	24006197	24006197	24006197
6	28	Bearing	24006228	24006228	24006228	24006228	24006228
7	28	Ring	24018007	24018007	24018007	24018007	24018007
8	28	O-Ring MIM 45/60-10	24024062	24024062	24024062	24024062	24024062
9	28	O-Ring MIM 80/110-12	24024093	24024093	24024093	24024093	24024093
10	28	Washer	30610290	30610290	30610290	30610290	30610290
11	28	Spacer	30610291	30610291	30610291	30610291	30610291
	28	Seal ring OR3143	24024021	24024021	24024021	24024021	24024021
	28	Seal ring OR3118	24024019	24024019	24024019	24024019	24024019
12	28	Ring nut $\varnothing$ 92x18	30620151	30620151	30620151	30620151	30620151
13	28	Reducer upper cap	30830100	30830100	30830100	30830100	30830100
14	28	Cover $\varnothing$ 92	31010135	31010135	31010135	31010135	31010135
15	28	Cap $\varnothing$ 110	31020067	31020067	31020067	31020067	31020067
16	28	Cover $\varnothing$ 110	31020068	31020068	31020068	31020068	31020068
17	28	Gear Z=55	31450028	31450028	31450028	31450028	31450028
18	28	Worm screw	31630010	31630010	31630010	31630010	31630010
19	28	Assembly retainer	31810020	31810020	31810020	31810020	31810020
20	28	Trolley reduction box	32830067	32830067	32830067	32830067	32830067

Table 22 Machine components: ref. Fig. 28

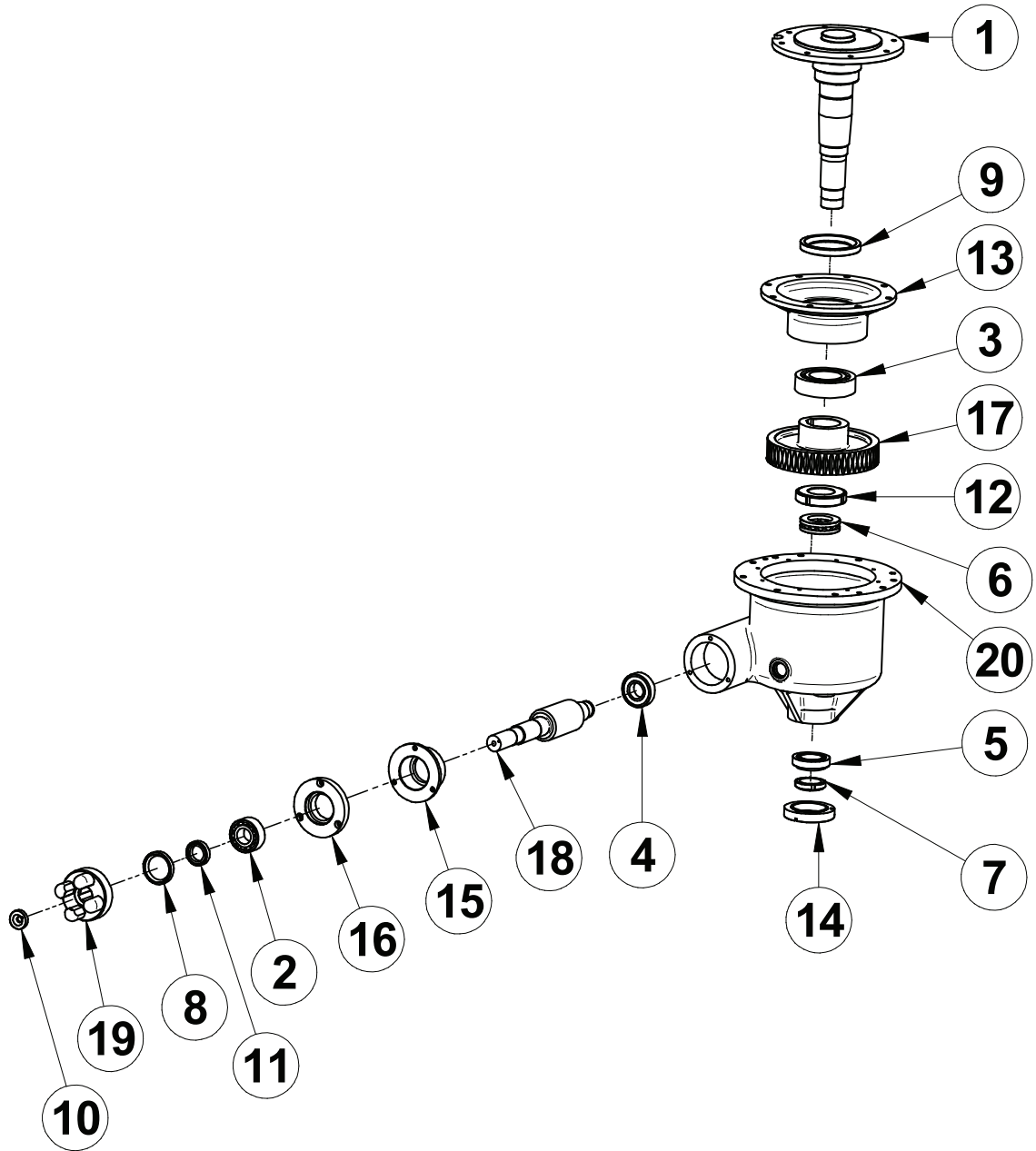

Fig. 28 Machine components: table 22

## 12.13 Hydraulic scheme and list of components

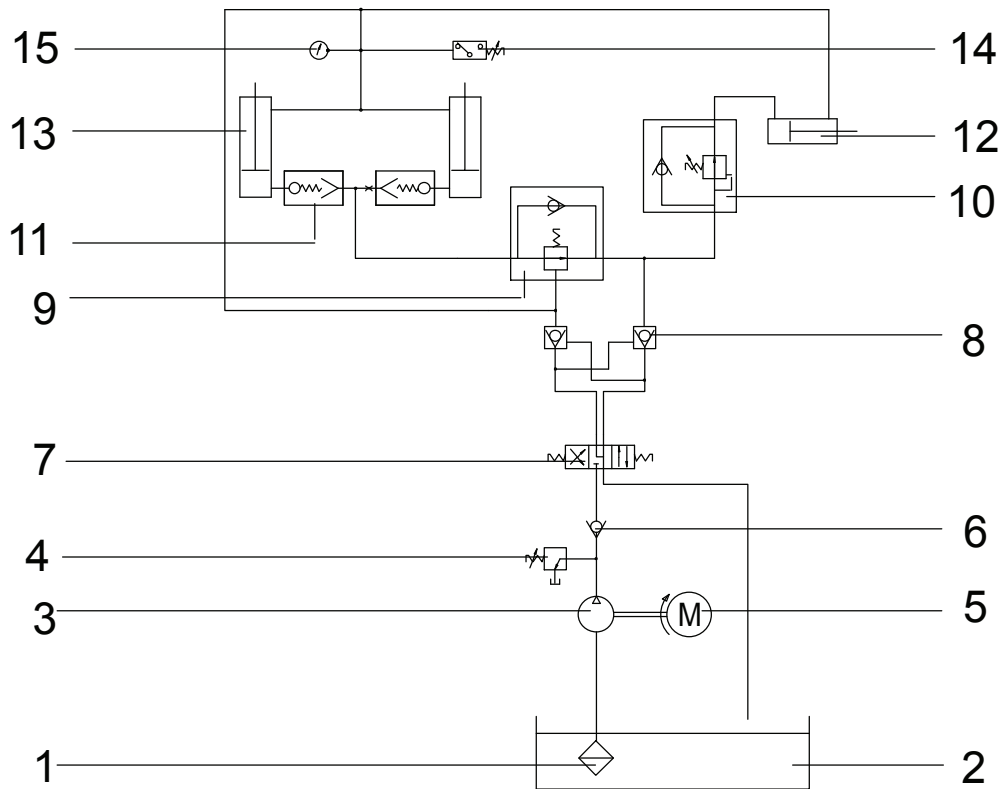

Fig. 29 Hydraulic scheme

Ref.	Fig.	Description	EVO 130	EVO 160	EVO 200	EVO 250	EVO 300
1	*	Filter					
2	*	Tank					
3	*	Pump	24000040	24000040	24000040	24000040	24000040
4	*	Pressure regulator					
5	*	Motor	22000372	22000372	22000372	22000372	22000372
6	*	No return valve	24000043	24000043	24000043	24000043	24000043
7	*	Solenoid valve					
8	*	Controlled non return valve					
9	*	Descent control valve	24000133	24000133	24000133	24000133	24000133
10	*	Sequence valve					
11	*	Fall security valve	24000080	24000080	24000080	24000080	24000080
12	*	Trolley coupler piston	24002036	24002036	24002036	24002036	24002036
13	*	Head lifting pistons	24002037	24002039	24002039	24002039	24002039
14	*	Pressure switch	24000134	24000134	24000134	24000134	24000134
15	*	Manometer					

\* Fig. 29 on page 80, Fig. 30 e Fig. 31 on page 81, Fig. 32 on page 82

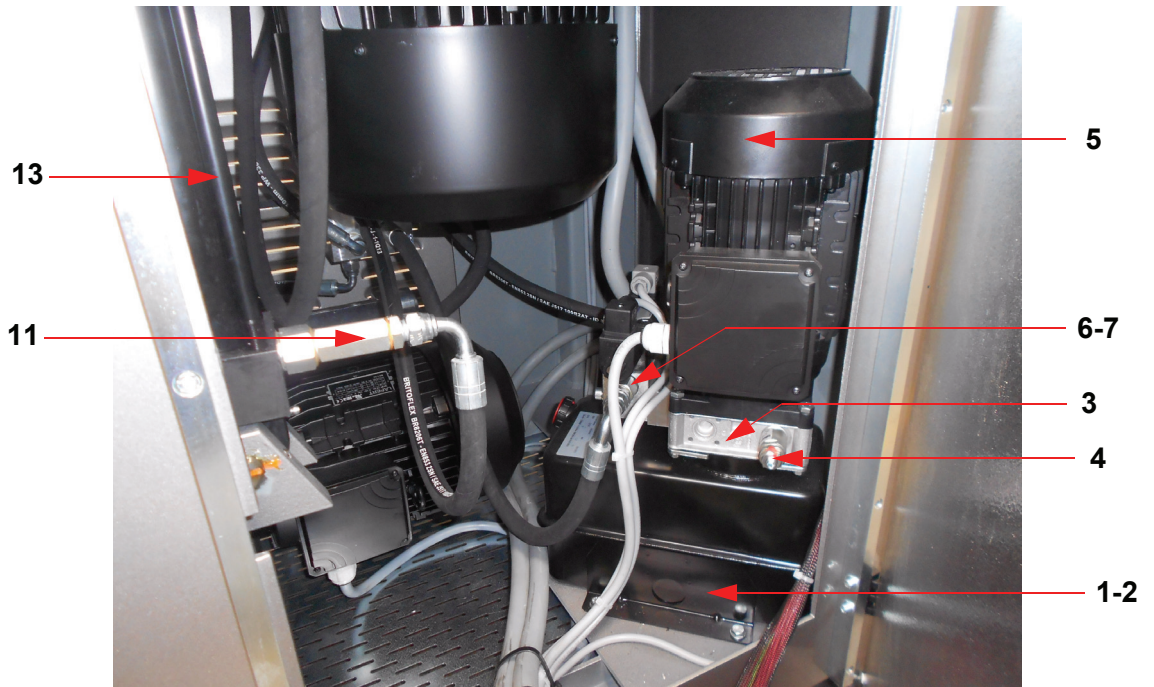

Fig. 30 Hydraulic scheme view 1

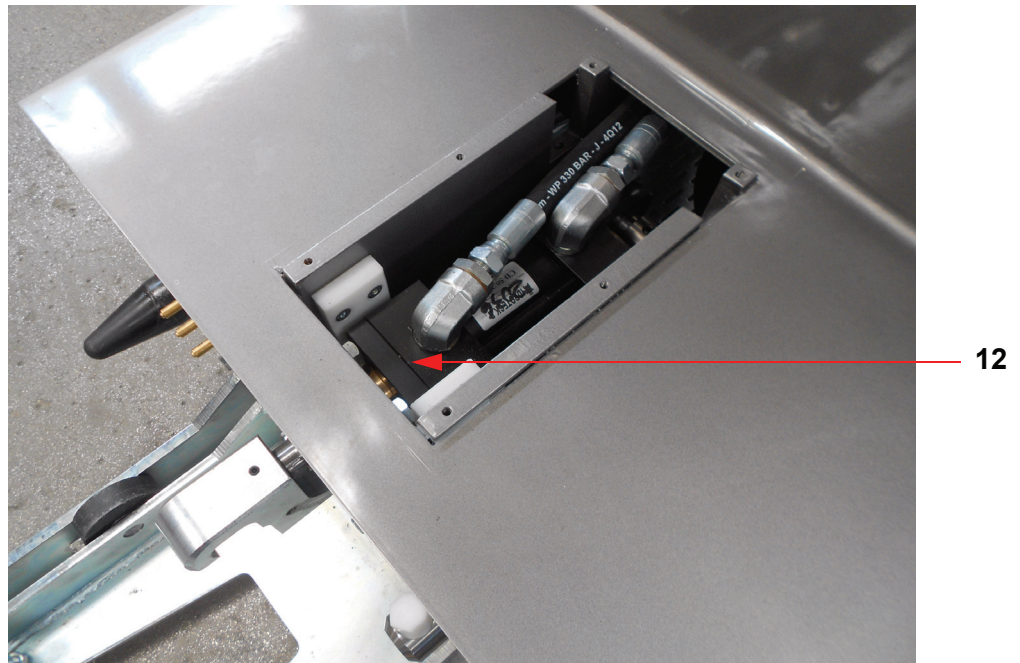

Fig. 31 Hydraulic scheme view 2

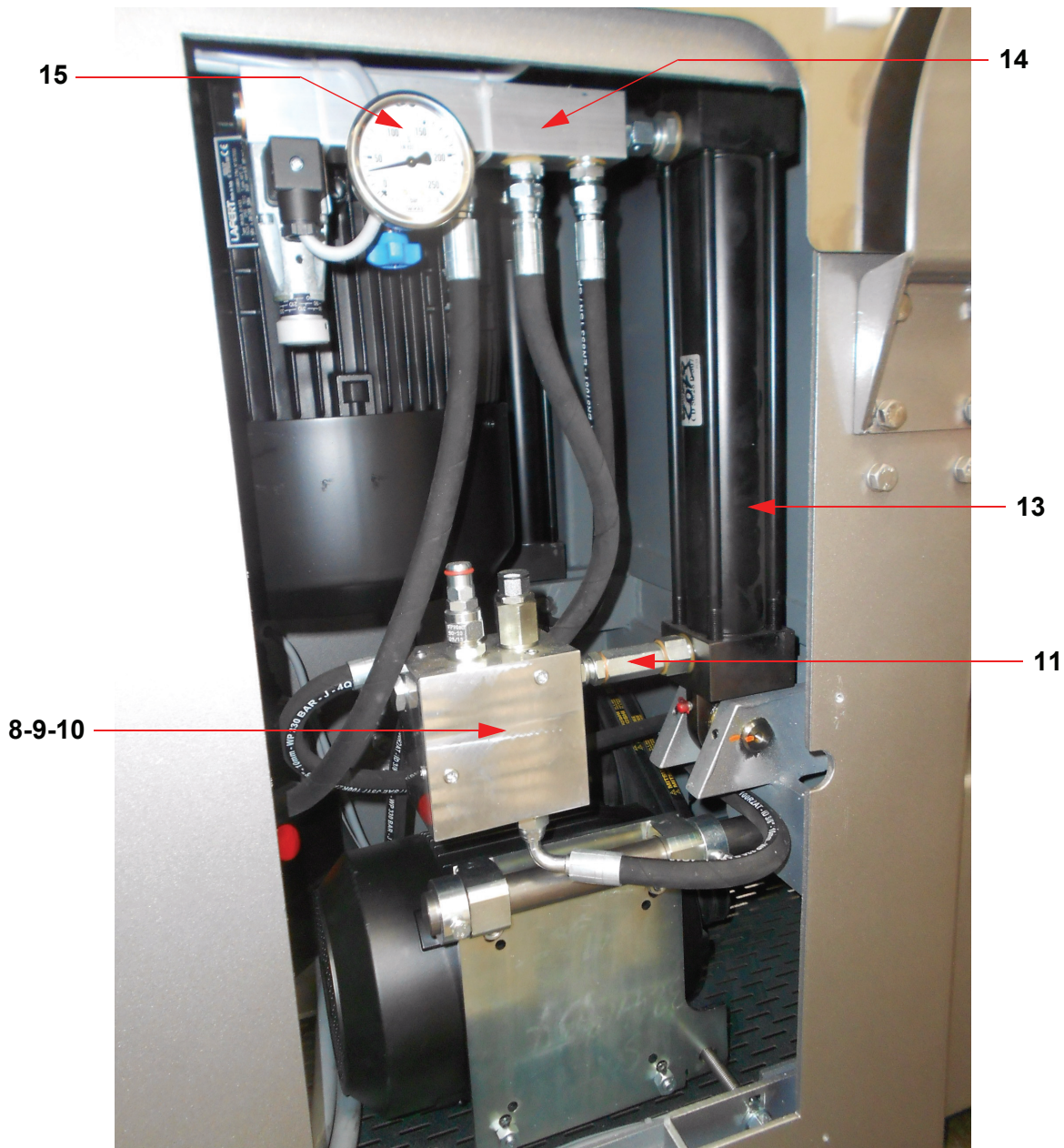

Fig. 32 Hydraulic scheme view 3

# Index

## A

Attached documentation ..... 61

## C

Checks before start-up ..... 38

Commissioning ..... 34

Correct use of the machine ..... 39

Customer's responsibility ..... 10

## D

Dismantling and scrapping ..... 61

## E

Electrical hazards ..... 31

Electrical maintenance ..... 53

    Replacing a fuse ..... 53

    Resetting a thermal cut-out ..... 53

Emergency fire regulations ..... 16

## F

First aid regulations for the use of lubricants ..... 17

First start-up ..... 34

## G

General precautions

    - Prohibitions ..... 15

    - Skills and checks ..... 13

    - Training ..... 13

    - Workplace ..... 15

General warnings ..... 10, 45

Graphic conventions ..... 7

## H

Handling and installation ..... 19

Handling instructions ..... 19

Hydraulic scheme and list of components ..... 80

Hygiene regulations for the use of lubricants ..... 16

## I

Identification ..... 5

Improper use ..... 39

Inactivity and restart ..... 36

Installation, Connection to the mains power supply ..... 33

Installation area ..... 22

Introduction and purpose of manual ..... 6

IP protection rating ..... 28

<b>L</b>	
List of components and spare parts .....	65
List 01 .....	65
List 02 .....	66
List 03 .....	68
List 04 .....	68
List 05 .....	68
List 06 .....	68
List 07 .....	71
List 08 .....	72
List 09 .....	74
List 10 .....	76
List 11 .....	77
List 12 .....	78
<b>M</b>	
Machine controls .....	40
Main components .....	25
Maintenance	
Daily maintenance .....	54
Quarterly maintenance .....	54
Maintenance instructions .....	45
Marking .....	5
Mechanical hazards .....	28
Mechanical maintenance .....	47
<b>N</b>	
Noise level .....	27
<b>O</b>	
Operating conditions .....	28
Operational limits .....	39
Operational principles .....	25
Ordinary functions .....	42
Other components .....	25
Other emissions .....	27
<b>P</b>	
Periodic cleaning .....	45
Positioning instructions .....	21
Power consumption .....	27
Precautions on receipt of the product .....	19
Product specification .....	23
Production and elimination of waste material .....	27
<b>Q</b>	
Quick reference guide .....	37
<b>R</b>	
Reactive maintenance .....	55
Replacements .....	55
Replacing the bowl motor .....	56

Replacing the kneading tool .....	58
Replacing the kneading tool motor .....	55
Replacing the motor (ref. 3 Fig. 13 on page 49) of the hydraulic unit .....	57
Reference manuals for third party components .....	61
Replacing the bowl drive belts .....	49
Replacing the kneading tool drive belts .....	47
Residual risks and special guards .....	28
Routine maintenance .....	46
Tension of belts .....	51
Running in .....	36
<b>S</b>	
Safety information .....	13
Safety precautions .....	37, 45
Safety signs installed on the machine .....	63
Shipping, handling and positioning .....	19
Spare parts .....	11
Staff qualifications .....	9
Stop functions .....	43
Storage conditions .....	28
Subsequent handling .....	21
<b>T</b>	
Technical service .....	11
Technical specifications .....	26
Troubleshooting .....	59
<b>U</b>	
Unpacking and disposal of packaging materials .....	22
User instructions .....	37
Using the Manual .....	6
<b>W</b>	
Warranty conditions .....	7



