

SPF45S

PROFESSIONAL SPLIT TANK FRYER - 2 BASKET

OPTIONS: Natural or LPG Gas



GUARANTEED PERFORMANCE

Smeg catering products draw on the experience of approximately 40 years in the Foodservice industry. Our products are built with the highest quality materials, making them particularly tough and strong.

PERFORMANCE

The Smeg Fryer is powered by a highly effective, energy-efficient target burner to ensure even heat distribution throughout the oil; perfect for large quantity frying. Additionally, it not only assists in temperature recovery time but reduces gas consumption. Our fryers also feature an over-temperature safety cut-out switch. This not only protects the fryer from overheating and breaking down, but it also protects the safety of your staff as well.

VERSATILITY

The complete Smeg Professional catalogue offers a range of products for all needs and environments, fulfilling any requirement in the most efficient and high-performing way.

PRODUCT FEATURES

- AISI Grade Stainless Steel
- Stainless steel constructed pan with center cool zone – 1.5mm
- Efficient dual multi-jet target burner
- +/- 3°C temperature recovery differential
- Over-temperature safety cut-out switch
- 13.5L oil capacity per section
- Heavy duty lockable oil drain valve
- Flame Failure - Included as standard
- Piezo ignition to pilot multi-jet target burner
- Complete with baskets, fish plate and night cover
- Front access to all components makes service easy
- Pan Dimensions: 415mm D x 300mm W x 80mm H
- (Height is measured from the base plate to the oil level mark)
- Dimensions (mm) (WxDxH): 450x840x1030
- **12 months parts and labour warranty**

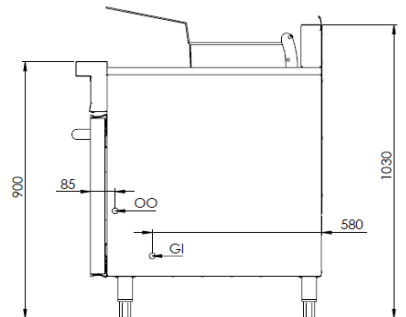
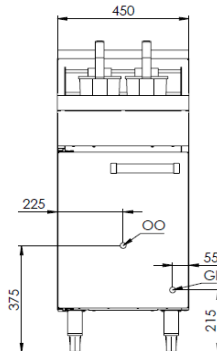
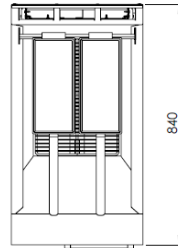

Combination control valve with inbuilt regulator is supplied within the unit
 Must be installed by an authorised installer in accordance to AS/NZS5601 refer to current version
 Due to ongoing Product Development, Product Improvement and Research, Smeg Professional reserves the right to alter specification without notice.
 Approval Number: GMK 10683

