

ORCHESTRA 10

Pasta machine



- Designed for medium-duty operations i.e. catering, large restaurants, cafeterias.
- Stainless steel AISI 304 construction. Stainless steel worm, head and ring.
- Powerful, air-cooled motor with oil bath gearbox.
- 2-speed operation, stainless steel controls IP67 dustproof and waterproof rating.
- Reliable, user-friendly and easy to clean. The bowl is quickly disassembled and removed.
- High-performance and easy to remove kneading paddle.
- Interlocked and see-through stainless steel lid.
- Convenient removable funnel to add liquid ingredients during processing.
- Variable-speed pasta cutter accessory available.



Frio 10
Optional head cooling kit

Optional

- Pasta cutter
- LF202510062 Rack
- LF202510068 Dryer

Specifications

- Safety:** Bowl lid is interlocked
Overload protection
No voltage release prevents inadvertent reactivation after a power outage
- Sanitation:** Bowl and extruding end are quickly disassembled and removed

- Construction:** AISI 304 Stainless Steel
Motor: 750W
Electrical: 220-240V AC, 60Hz, 5.5A
Pasta cutter: 110V, 60 Hz
Plug and Cord: SJTO AWG 14, NEMA 6-15 P
Controls: ON/OFF stainless steel keypad. IP 67 waterproof.
No voltage release.



Certified to UL Standard 763 and NSF Standard 08
 Certified to CSA Standard C22.2

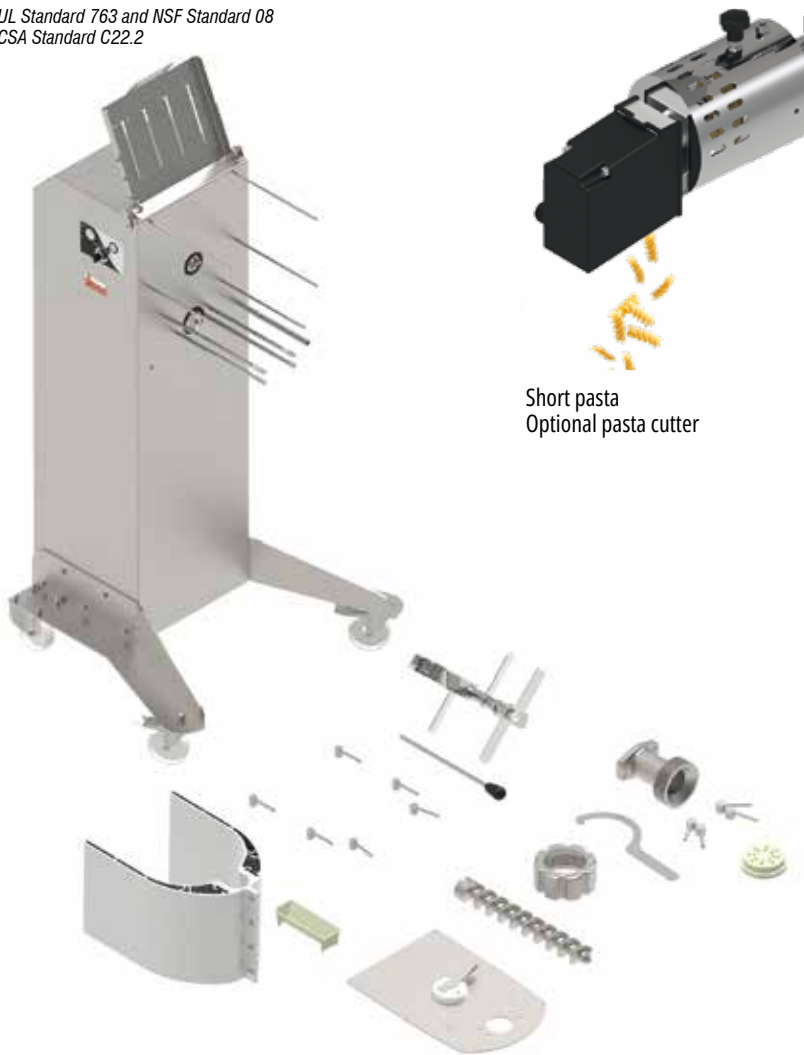

Short pasta
 Optional pasta cutter



Optionals
 RACK: tray holder
 DRYER: pasta dryer

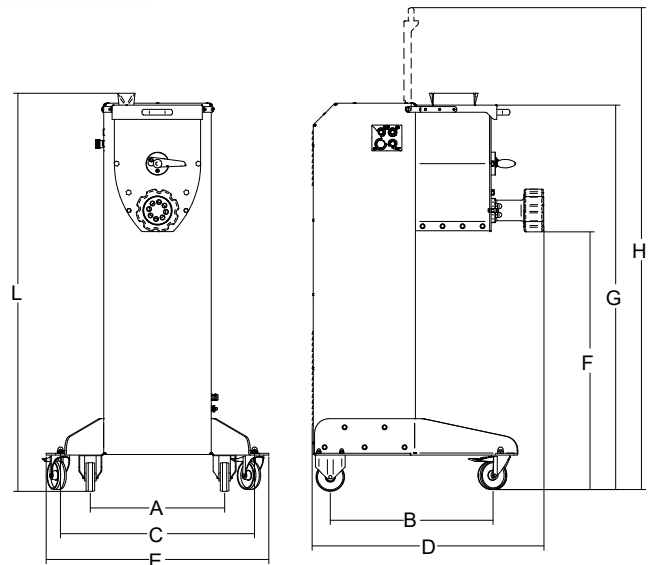

| | Power | Power source +/- 10% | Bowl capacity | Dough capacity | Output/h. | Dies | A | B | C | D | E | F | G | H | L | Net weight | Shipping | Gross weight |
|---------------------|---------|-------------------------|---------------|----------------|-----------|------|---------|----------|-----------|-----------|-----------|-----------|-------|-----------|-----------|------------|---------------------------------|--------------|
| | watt/Hp | | qt | lbs. | lbs./h. | ø mm | inch. | inch. | inch. | inch. | inch. | inch. | inch. | inch. | inch. | lbs. | inch. | lbs. |
| Orchestra 10 | 2.250/3 | 220-240V, 60Hz | 22 | 21.6 | 44 | 110 | 18 1/2" | 22 7/16" | 26 49/64" | 31 31/32" | 30 45/64" | 35 33/64" | 53" | 66 27/64" | 54 23/32" | 260 | 37 1/64" x 41 17/32" x 61 1/32" | 298 |