



MIRRA

affettatrici gravità

gravity slicers

- Fusione in lega di alluminio anodizzato
- Ampio spazio tra motore e lama per un'agevole pulizia
- Motore ventilato
- Lama forgiata e temprata a forte spessore
- Scorrimento carrello su boccole autolubrificanti e perni lappati
- Viteria e parafetta in acciaio inox
- Robusto supporto vela
- Affilatoio incorporato con corpo in fusione e doppio smeriglio di serie
- Dimensioni compatte ma con grande capacità di taglio
- Versione CE Professionale con sblocco su carro
- Disponibili lame teflonate o dentate
- Inclinazione lama 25°

- Anodized cast aluminum alloy
- Great distance between blade and motor for easy cleaning
- Ventilated motor
- Forged, hardened large thickness blades
- Carriage running on self-lubricating bushes and lapped pins
- Stainless steel screws and slice deflector
- Strong thickness gauge support
- Cast-in body sharpener assembly with 2 standard emery-wheels
- Compact dimensions but great cutting capacity
- Device for releasing the carriage on CE version
- Teflon coated or toothed blades are available on demand
- 25° blade inclination



MIRRA 250 C



MIRRA 275 C



MIRRA 220 C



Ampio spazio per la pulizia
Large space for cleaning



Protezione paracqua su puleggia
Enclosed and sealed belt pulley

Optional



Parafetta tondo rimovibile su mod. 250
Removable round slicer deflector on mod. 250

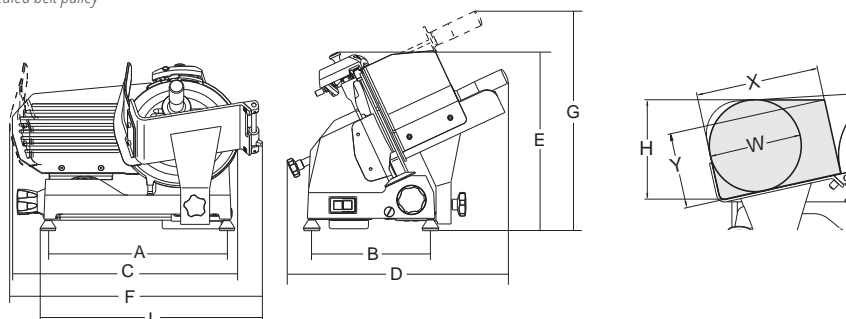

	mm-inch	watt-Hp	mm	mm	mm	mm	mm	mm	mm	mm	mm	mm	mm	mm	mm	mm	kg	mm	kg	
Mirra 220 C	220/9"	147/0,20	13	245	230x240	395	245	480	560	370	570	475	505	220	125	160	160	15	600x500x420	17
Mirra 250 C	250/10"	147/0,20	13	245	230x240	395	245	500	560	370	570	475	490	220	145	180	170	16	600x500x420	18
Mirra 275 C	275/11"	147/0,20	13	245	230x240	395	245	535	560	370	570	475	475	215	160	200	190	17	600x500x420	20