

Trade Waste Solutions



250mm Square Floor Waste Arrestor (suits 150mm pipe)



FW-250BS-150-304

FW-250BS-150-316

- Hinged Grate
- Heel Proof
- Fixed Strainer
- Removable Basket
- 304 or 316 Grade Stainless Steel
- Suits 150mm DWV, HDPE Pipe

Top

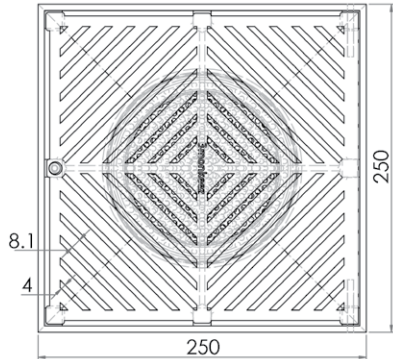

Front

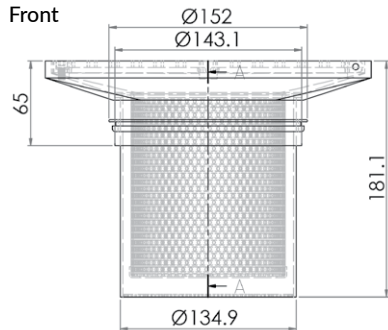

FW-BASKET-150

Cross Section

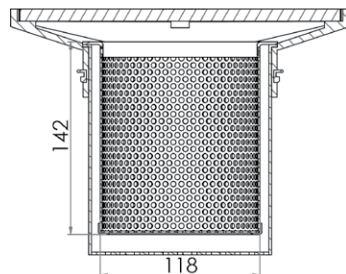

*Exclusions apply

3monkeez.com.au

