

ZOE COMPACT



Technical data		2 GROUP
voltage	V	220-240 1N, 50/60Hz
required amperage	A	15
power input	kW	2.7
steam boiler capacity	lt	7
steam boiler element	kW	2.4
pump power	kW	0.13
net weight	kg	45

INDUSTRY
KITCHENS

www.industrykitchens.com.au 1800 611 058



Features



ELECTRONIC AUTO-LEVEL

Through an electronic level probe, the boiler is automatically filled and maintained to the right filling level.



ACTIVATED ELECTRONIC PREINFUSION

Management of the delayed activation of water solenoid in the first phase of brewing.

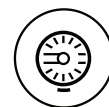

DOUBLE READING GAUGE

Allows you to control the boiler pressure and the distribution pressure at the same time.



AUTOMATIC CLEANING CYCLE

Process for coffee groups cleaning.



EASY SERVICE

Fast access to the internal parts, for quick and easy technical service.

Compact version

2 GROUP

2 steam taps

1 water tap

1 one-cup portafilter

2 two-cup portafilters



ZOE COMPACT



Standard height only

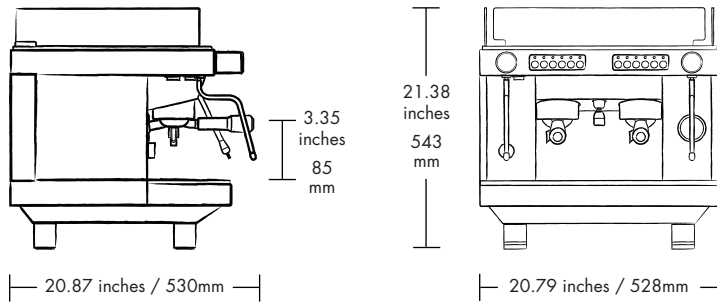

Easily Customisable Panels

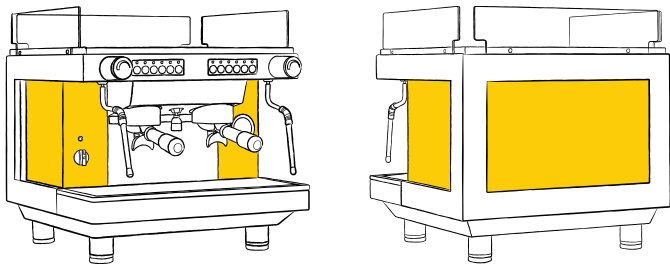

Easily removable panels for easy customisation.

Colours



All images are subject to illustrative purpose. The manufacturer reserves the right to modify without prior notice the technical characteristics indicated in this document.

CONTACT US

info@sanremomachines.com.au
sanremomachines.com.au

