



# GLASSWASHER UX-40SB 230/50/1 DD AUS

Rack size 400x400mm and door clearance 300 mm. Double-skinned construction.



P/N 1303119



WARE WASHING  
COMMERCIAL GLASSWASHERS

## SALES DESCRIPTION

Sani-Control: guaranteed disinfection  
Embedded bodywork and easy-grip door: hygienic and ergonomic  
Double-walled body: insulation and energy efficiency  
Exclusive Hydroblade™ washing arms: maximum effectiveness.  
3-stage filtering system.

### Sani-Control guarantee

- ✓ GUARANTEED DISINFECTION in compliance with standard DIN 10534.
- ✓ THERMAL LOCK function: Ensures that rinsing will be carried out at the ideal temperature to disinfect the dishes.

### New recessed bodywork

- ✓ Ergonomic design with rounded corners to prevent the accumulation of dirt and facilitate cleaning.
- ✓ Compact tank volume (50% water saving compared to the previous range).
- ✓ Embedded basket guides

### Double-Walled (Ultra ISO)

- ✓ Double-Walled Structure: thermo-acoustic insulation to attenuate the sound level and improve energy efficiency

### Hydroblade™ washing arms

- ✓ Redesigned nozzles for greater washing performance.
- ✓ The “monoblock” design delivers durability and resistance to impacts.
- ✓ 30% savings in water consumption during rinsing compared to the previous range.

### 3-stage filter system: surface, tank and extraction

- ✓ Keeps the washing water in optimal conditions to maintain constant

washing performance.

- ✓ The surface filters feature an “easy-on” design and can be quickly removed without having to disconnect the washing arms.

### “Easy grip” door: new design with integrated door handle

- ✓ The integration of the components provides greater resistance and robustness.
- ✓ Designed to have no corners or areas that are difficult to access: prevents deposits of dirt and facilitates cleaning.
- ✓ Its ergonomic handle provides a perfect grip, even with wet hands.
- ✓ Double-walled door with safety microswitch and high quality seal
- ✓ 30 cm load capacity: high versatility for washing a wide range of glasses and even medium-sized dishes.

### Premium warewashing

- ✓ Ultra Xperience: high performance, without complications.
- ✓ Soft start: progressive start-up of the washing pump to protect fragile items.
- ✓ Colour LCD Display: intuitive communication of the machine status by means of messages, colour codes and icons.
- ✓ Dedicated cycles: selection of the ideal washing programme using icons.
- ✓ Adaptable: allows the main parameters of the machine to be adjusted to the needs of each user.
- ✓ TEMPERATURE DISPLAY
- ✓ Wash Plus+ function: increases the intensity of the wash cycle for greater cleaning performance
- ✓ Control panel with IP65 humidity protection.

### You will never WASH ALONE

- ✓ Tech-Services: our team of technicians will help you so that your machine is always ready for use.
- ✓ Design Services: tell us what your needs are and we will advise you.
- ✓ 60 years of experience and know-how at your disposal.

## INCLUDES

- ✓ Detergent Dispenser.
- ✓ Rinse aid pump.
- ✓ Drainage pump with level sensor. Proactive tank water renewal.
- ✓ 1 glasses basket.
- ✓ 1 mixed basket (plates).
- ✓ 1 small basket for cutlery.

## OPTIONAL

- Double-level accessory for washing two baskets at the same time.

## ACCESSORIES

- Manual water softeners
- Automatic water softeners
- 400 x 400 mm baskets
- Inserts & supplements
- High feet kit
- Reverse osmosis devices OS-140
- Stand for 400x400 mm glasswashers
- Double rack kits for AX/UX

## SPECIFICATIONS

Basket dimensions: 400 mm x 400 mm  
Useful height: 300 mm

Cycle duration: 90 / 120 / 150 / 180”  
Production baskets / hour: 43/30/24

Boiler capacity: 4.5 l  
Wash tank capacity: 9 l

### Consumption and savings

Water consumption/cycle: 1.9 l



product sheet  
updated 20/01/2024



# GLASSWASHER UX-40SB 230/50/1 DD AUS

Rack size 400x400mm and door clearance 300 mm. Double-skinned construction.



P/N 1303119

Automatic saving mode in: 25'  
Automatic switch-off: 120'

### Loading

- ✓ Pump: 250 W / 0.33 Hp
  - ✓ Tank: 1200 W
  - ✓ Boiler: 2500 W
  - ✓ Total loading: 2750 W
- Electrical supply: 230 V / 50 Hz / 1~ (13.3 A)

- ✓ Width: 490 mm
  - ✓ Depth: 540 mm
  - ✓ Height: 710 mm
- Net weight: 41.5 kg  
Noise level (1m.): <69 dB(A)

**Crated dimensions**  
525 x 615 x 820 mm  
Gross weight: 47.5 kg

### External dimensions (W x D x H)

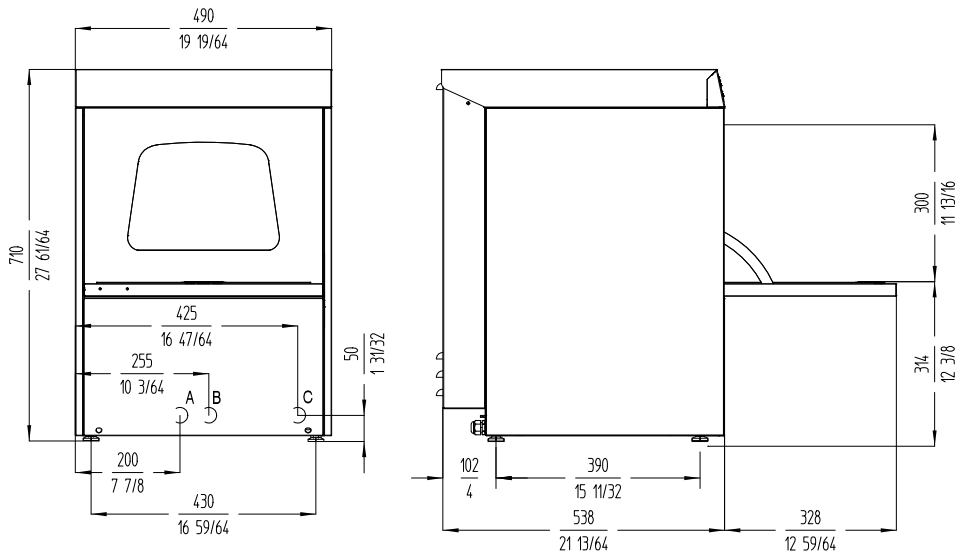

A: Entrada de agua 3/4" GAS.  
B: Tubo de desague Ø30 mm.  
C: Cable conexión

WARE WASHING  
COMMERCIAL GLASSWASHERS

**sammic** | www.sammic.com  
Food Service Equipment Manufacturer

Polígono Basarte, 1. phone +34 943 15 72 36  
20720 Azkoitia, Spain sales@sammic.com



Project	Date
Item	Qty
Approved	

product sheet  
updated 20/01/2024