



FOOD-PROCESSOR - EMULSIFIER KE-4V

Bowl capacity: 4.4 l. Adjustable speed with "brushless" technology.

INDUSTRY KITCHENS

www.industrykitchens.com.au 1800 611 058



SALES DESCRIPTION

- ✓ Compact ULTRA line. Variable speed motor block + 4.4 l cutter bowl with lateral stirrers and toothed blades.
- ✓ Ideal for emulsions and texturizations.
- ✓ Brushless technology: maximum efficiency.

Equipped with "brushless" technology: powerful and efficient motors.

- ✓ Maximum efficiency: maintain the torque throughout the speed range.
- ✓ Lightweight and compact design: they weigh less, they occupy less space.
- ✓ Improved air/water-tightness since no ventilation is required.
- ✓ They generate less noise: improved workplace environment.

Efficiency and performance.

- ✓ Possibility of programming by time and pulse button.
- ✓ 4.4 l bowl equipped with lateral stirrer and high shaft for larger production capacity.
- ✓ Transparent lid equipped with hole to add ingredients in use.
- ✓ Lid complete with gasket to avoid product overflowing.
- ✓ Homogeneous and fine mixing result thanks to the lateral stirrers and inverted blade.
- ✓ The lateral stirrers avoid product overheating.
- ✓ Very uniform finish due to the movement generated the special position of the cutting edges.
- ✓ Depending on usage, optional smooth or perforated blades available.
- ✓ Built-in parametrisable programs to obtain the desired texture in seconds and in a standardized way: dense texture, fine texture, pulses (PrecisePulse function).
- ✓ Option to customize programs for recipe standardization.
- ✓ Optional vegetable slicer attachment available.

Built to last

- ✓ Sturdy construction in food-grade best quality materials.

Maximum comfort for the user

- ✓ Cutter bowl equipped with ergonomic handle.
- ✓ Advanced control panel that is very intuitive to use and offers all the information at a glance.
- ✓ Control panel equipped with timer to standardise processes.
- ✓ Recessed cord relief allowing flush against wall operation

Maintenance, safety, hygiene

- ✓ Safety microswitches in the position of the bowl and the lid.
- ✓ Complete error warning system.
- ✓ Appliance certified by NSF International (regulations on hygiene, cleaning and materials suitable for contact with foods).
- ✓ 100% tested.

INCLUDES

- ✓ Variable speed motor block.
- ✓ Cutter bowl with toothed blades.

OPTIONAL

- Hub with smooth blades.
- Vegetable slicer attachment.
- Hub with perforated blades.

ACCESSORIES

- Cutter bowl
- Vegetable preparation attachment for K-41 / KE-4V
- Hubs with blades

SPECIFICATIONS

Bowl capacity: 4.4 l
 Max. product capacity: 2.5 kg
 Maximum capacity (liquid): 2.4 l
 Bowl dimensions: Ø193 mm x 161 mm
 Total loading: 1100 W
 Speed, min-max: 300 rpm - 3000 rpm

External dimensions (W x D x H)

- ✓ Width: 252 mm
- ✓ Depth: 309 mm
- ✓ Height: 434 mm

Net weight: 11.9 kg

Crated dimensions
 285 x 385 x 695 mm
 Volume Packed: 0.08 m³
 Gross weight: 16.1 kg

AVAILABLE MODELS

1051000 Cutter-emulsifier KE-4V 230/50-60/1

1051004 Cutter-emulsifier KE-4V 230/50-60/1 UK

1051008 Cutter-emulsifier KE-4V 120/50-60/1

* Ask for special versions availability



product sheet updated 31/01/2025

DYNAMIC PREPARATION CUTTER-MIXERS & EMULSIFIERS



FOOD-PROCESSOR - EMULSIFIER KE-4V

Bowl capacity: 4.4 l. Adjustable speed with "brushless" technology.



DYNAMIC PREPARATION
CUTTER-MIXERS & EMULSIFIERS

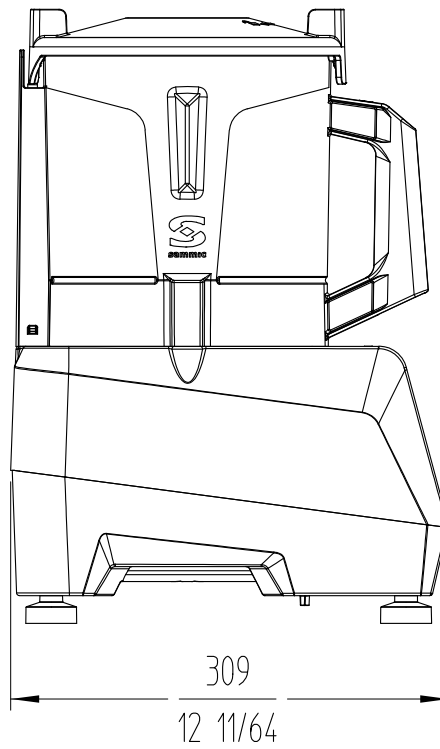
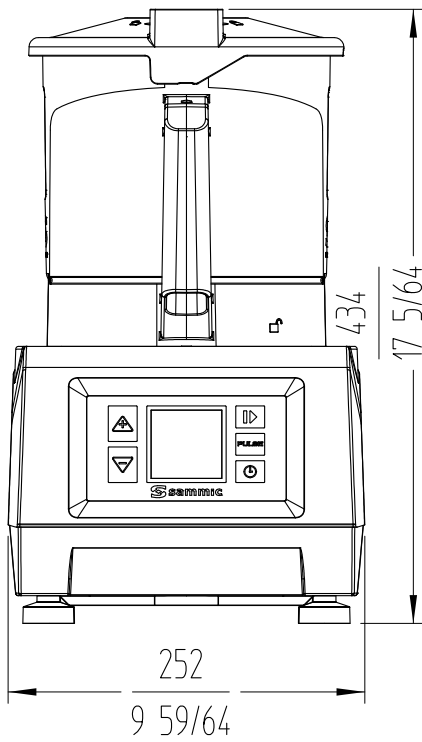

sammic | www.sammic.com
Food Service Equipment Manufacturer
 Polígono Basarte, 1. phone +34 943 15 72 36
 20720 Azkoitia, Spain sales@sammic.com



Project	Date
Item	Qty
Approved	

product sheet
updated 31/01/2025