

# Crowning. Salvis Salamander

INDUSTRY  
KITCHENS

[www.industrykitchens.com.au](http://www.industrykitchens.com.au) 1800 611 058



*smart cooking*



## Crowning. The Salamander by Salvis.

For every type of application.  
High quality. Versatile. Quick.



### Salvis Salamander Vitesse

This model has a lot more useful features besides its outstanding material quality and ease of cleaning.

#### ■ User-friendly

Due to its 4-sided accessibility, its efficiency can be increased and work becomes simpler.

#### ■ Multifunctional

The Salamander Standard can be remodelled into a wall, table or ceiling mounted model.

#### ■ Design

The exclusive and lavish design has something to show. The Vitesse model can be used in any designer kitchen, show kitchen or in the front cooking area.

Vitesse model >



### Salvis Salamander Classic and Classic Pro

The Classic models cover the traditional Salamander demand and feature the latest technology.

#### ■ Compact

Due to its compact exterior dimensions, it can be used in many areas, and can even be integrated into the ceiling hood.

#### ■ High quality

The stable design warrants a long product life, even if used daily and continuously.

#### ■ Automatic plate detection

The switchable clever function detects plates and bowls on its own and switches the Salamander on and off automatically. Due to the quick heating systems, you will save precious energy when cooking "au gratin".

Classic Pro model >



Classic model >



## Ecological and efficient.

Highest saving potential thanks to sophisticated technology.



### ■ Reflector

The well-designed heat reflector is equipped on all models with a patented double coat and a smart heating system; it prevents high temperatures on the reflector handle.

### ■ Timer

You will always achieve constant results, as the device will automatically switch off after the desired gratination time. This could be with the mechanical or electronic timer.

### ■ Operation

You have three operating modes to choose from. Manual, semi-automatic and fully automatic. The right solution for every application.

### ■ Hygiene

Thanks to the high-quality workmanship, large radii and the foldable plate rest, the cleaning process is quick and simple.

### ■ Heating systems

For all models, you have the choice between the traditional **Pipe heater** (RH) and the fast **HiLight heater** (HL).



Wall mounting



Cooker mounting



Base frame



Hood mounting

### Advantages of the Salvis plate detection

The innovative technology offered by Salvis allows efficient production with the lowest possible energy consumption.

#### Energy savings with plate detection

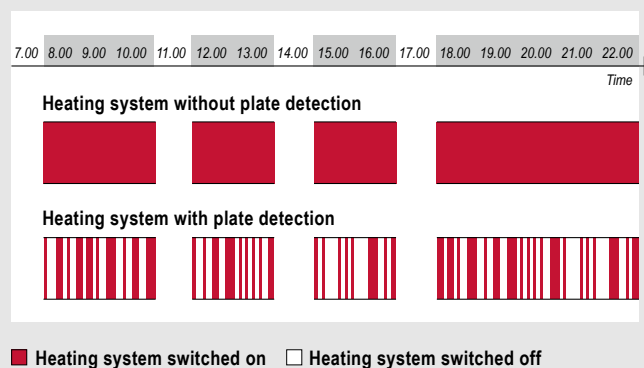

### ■ Conclusion

Up to 70% reduced power consumption with the Salvis plate detection.

Amortisation thanks to energy savings within 1¼ years.

(kWh à CHF 0.23 / EUR 0.15)

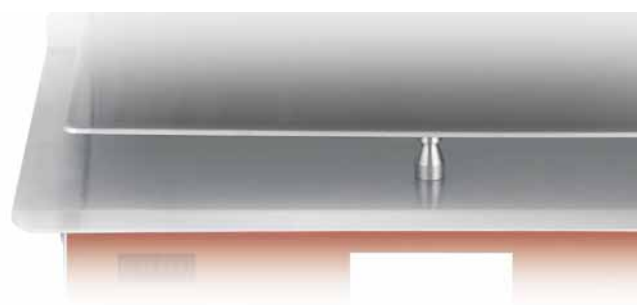

Matured

Sophisticated

Crowning

Outstanding

Leading

Hot

Ground-breaking

Complete

Strong

Intelligent



### ■ Technical data in brief

Technical data	Vitesse	Classic	Classic Pro
Tubular heating version	RH-ET	RH-ET-C	RH ET-C Pro
Item Nr.	SA 373'101	SA 373'200	SA 373'210
HiLight heating version	HL-ET	HL-ET-C	HL-ET-C Pro
Item Nr.	SA 373'105	SA 373'201	SA 373'211
Voltage	400 V 2N 50/60 Hz	400 V 2N 50/60 Hz	
Fuse	16 A	2 x 16 A	2 x 16 A
Dimensions LxDxH (mm)	600 x 500 x 772	600 x 480 / 520 x 456	
<b>Power – Type</b>	<b>RH</b>	<b>HL</b>	<b>HL</b>
Full power	4 kW	4,6 kW	4,6 kW
Left or right	2 kW	2,3 kW	2,3 kW
Standby	1 kW	1,1 kW	1,1 kW

RH = Tubular heating HL = HiLight heating

Whether it be a grid, a drip pan or other accessories – Salvis will take care of you.  
Subject to modifications of performance, dimensions and design. Special voltages available upon request.

#### Salamander Vitesse

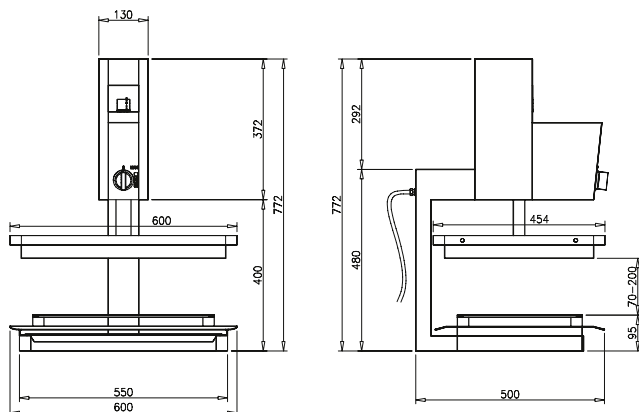

#### Salamander Classic and Classic Pro

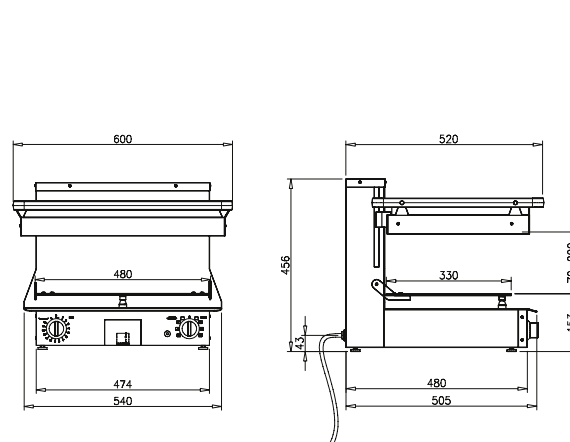

#### SALVIS AG

Nordstrasse 15

CH-4665 Oftringen

www.salvis.ch

Telephone +41 62 788 18 18

Telefax +41 62 788 18 98

09/2009 - 22000019

smart cooking

