

UNDER COUNTER

FEATURES

SUF12-2

• FRONT BREATHING

Our innovative, front breathing feature also allows this model to provide high efficiency in narrow spaces.

• HOT GAS CONDENSATE SYSTEM

Through SKIPIO's creative innovation, the condensate system surfaces have been specially treated to resist corrosion. This not only increases efficiency without the risk of refrigerant leakage from corrosion, but also prevents the overflow of condensate water.

• SIDE MOUNT COMPRESSOR UNIT

By positioning the compressor on the side of the unit, refrigerators can now be serviced without being moved.

• EFFICIENT REFRIGERATION SYSTEM

SKIPIO Undercounter series refrigerators are designed with oversized and balanced (CFC Free R-134A) refrigeration systems. These include efficient evaporators and condensers for faster cooling and greater efficiency.

• EXTERIOR & INTERIOR OF THE CABINET

SKIPIO Undercounter series boasts a stainless steel exterior (galvanized steel back and bottom.) Interior is stainless steel floor with AL sides, back and AL door liners. It guarantees the utmost in cleanliness and long product life. It can add a touch of style to the most refined setting.

• HIGH-DENSITY POLYURETHANE INSULATION

The entire cabinet structure is foamed-in-place using high density, CFC polyurethane insulation.

• ERGONOMICALLY DESIGNED DOORS

Customers' fatigue fades away with easy grip handles and doors that open effortlessly. These features along with self-closing doors make this the ultimate choice in customer convenience.

• MAGNETIC DOOR GASKETS

Magnetic door gaskets are of one piece construction, removable without tools for ease of cleaning and replacement.

• ADJUSTABLE, HEAVY DUTY, PE(POLYETHYLENE) COATED WIRE SHELVES



Sydney Branch

ADD: 218 Woodp
TEL: +61 2 8798 5061 / 5283 / 5581
X: +61 2 8798 5707
EMAIL: admin@skipio-australia.com

Melbourne Branch

ADD: 55 Lara Way Campbellfield VIC 3061
TEL: +61 3 8405 3359 / 9408 - 4081
X: +61 3 9408 9384
EMAIL: adminvic@skipio-australia.com

Brisbane Branch

ADD: 3/74 Murdoch Circuit, Acacia Ridge 4110 QLD
TEL: +61 7 3155 0250
EMAIL: adminqld@skipio-australia.com



UNDER COUNTER

MODEL	SUF12-2
Classification	Freezer
Cabinet Dimension (WxDxH mm)	1200 x 700(600) x 850
Capacity(Liters)	280
Inner Temperature(°C)	-21°C~-12°C
Ambient Temperature(°C)	38
Refrigent	R-404A
Insulation Type	Polyurethane/ Cyclopentane + CFC Free
Amps(A)	2.5A
Voltage(V/Hz/Ph)	240V / 50Hz / 1PH
Weight(Kg)	84
Power(W)	613W
Number of Doors	2
Compressor(HP)	1/3
Number of Shelves	2
Power plug	10A

PLAN VIEW

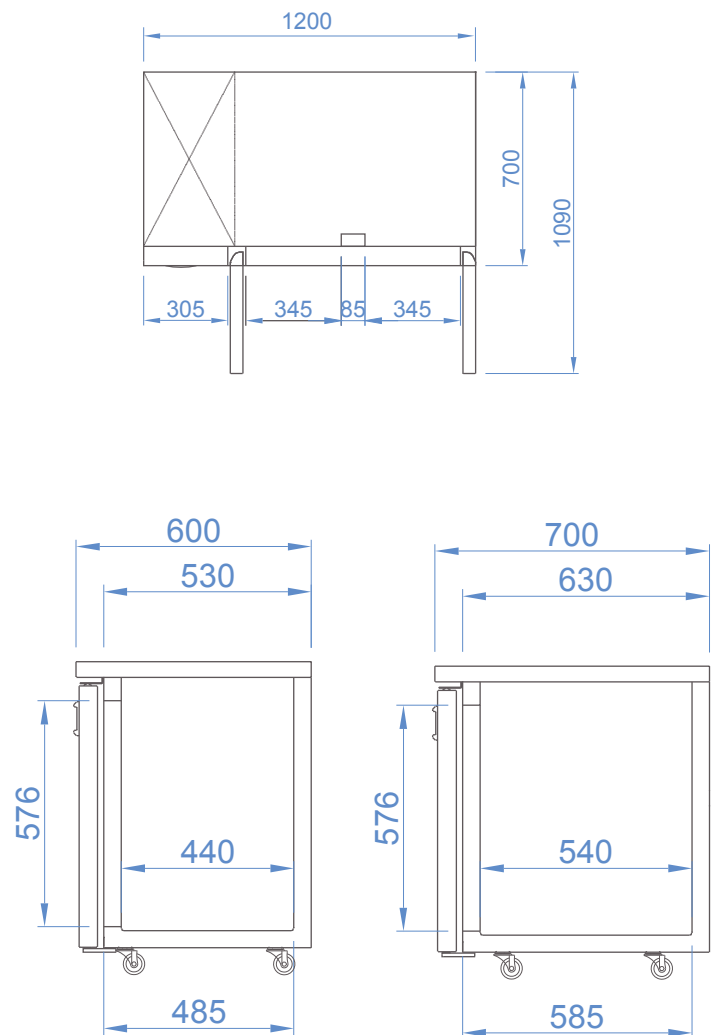

Sydney Branch
 ADD: 218 Woodp
 TEL: +61 2 8798 5061 / 5283 / 5581
 X: +61 2 8798 5707
 EMAIL: admin@skipio-australia.com

Melbourne Branch
 ADD: 55 Lara Way Campbellfield VIC 3061
 TEL: +61 3 8405 3359 / 9408 - 4081
 X: +61 3 9408 9384
 EMAIL: adminvic@skipio-australia.com

Brisbane Branch
 ADD: 3/74 Murdoch Circuit, Acacia Ridge 4110 QLD
 TEL: +61 7 3155 0250
 EMAIL: adminqld@skipio-australia.com

