



VACUUM SEALER SU-810

Floorstanding unit. 100m³/h. 530+848 mm.



FOOD PRESERVATION AND SOUS-VIDE
VACUUM PACKING MACHINES - "SENSOR ULTRA" LINE



FEATURES AND BENEFITS

- ✓ Powered by Busch.
- ✓ Vacuum controlled by sensor.
- ✓ Vacuum PLUS.
- ✓ LCD colour screen: all information at a glance.
- ✓ Backlit touch keyboard.
- ✓ Programmable: 25-programme memory. Blocking option.
- ✓ "Pause" button.
- ✓ Phased vacuum programme.
- ✓ Detection of the evaporation of liquids.
- ✓ Double seal.
- ✓ Cordless sealing bar.
- ✓ Progressive decompression.
- ✓ Vac-Norm ready with Automatic decompression.
- ✓ Stainless steel body and chamber.
- ✓ Damped transparent lid of high durability polycarbonate.
- ✓ Dry-oil programme for drying the pump.
- ✓ Working hours counter for oil changes.
- ✓ Safety system with protection against vacuum failure.
- ✓ NSF-listed.

INCLUDES

- ✓ BUSCH pump.
- ✓ Sensor Controls.
- ✓ 25 programmable settings.
- ✓ Vacuum PLUS: up to 10 seconds of extra vacuum pull.
- ✓ Soft air function.
- ✓ Clear methacrylate lid.
- ✓ "PAUSE" function.
- ✓ Liquid detection system.
- ✓ Dry oil cycle.
- ✓ NSF Approved.
- ✓ Filling plate.

OPTIONAL

- Inert gas
- Sealing plus
- Printer
- Vacuum packing bags
- External vacuum kit for Vac-Norm, containers and accessories
- Bag cutting kit
- Support for liquid packaging
- Additional filling plates

SALES DESCRIPTION

Two sealing bars (530+848 mm.)
 100 m³/h Busch vacuum pump.
 Vacuum controlled by sensor.



sammic | www.sammic.com
 Food Service Equipment Manufacturer

Polígono Basarte, 1. phone +34 943 15 72 36
 20720 Azkoitia, Spain sales@sammic.com



Project	Date
Item	Qty
Approved	

specification sheet
 update 11/21/17



VACUUM SEALER SU-810

Floorstanding unit. 100m³/h. 530+848 mm.



TECHNICAL SPECIFICATIONS

Pump capacity: 100 m³/h
 Bar length: 530 mm + 848 mm
 Total loading: 2200 W
 Vacuum pressure (maximum): 0.5 mbar

Internal dimensions

- ✓ Width: 864 mm
- ✓ Depth: 603 mm
- ✓ Height: 215 mm

External dimensions (WxDxH)

- ✓ Width: 960 mm
 - ✓ Depth: 757 mm
 - ✓ Height: 998 mm
- Net weight: 250 Kg
 Noise level (1m.): 75 dB(A)
 Background noise: 32 dB(A)

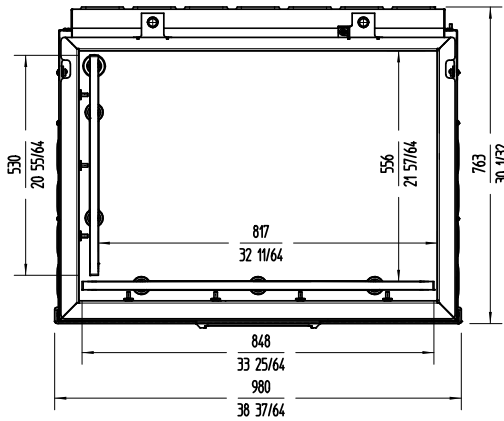
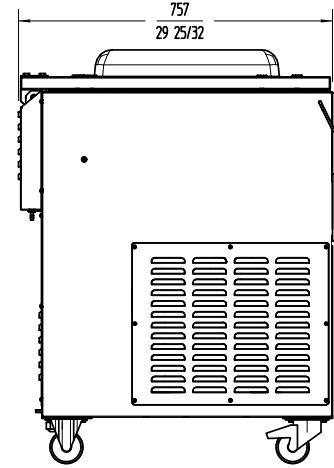
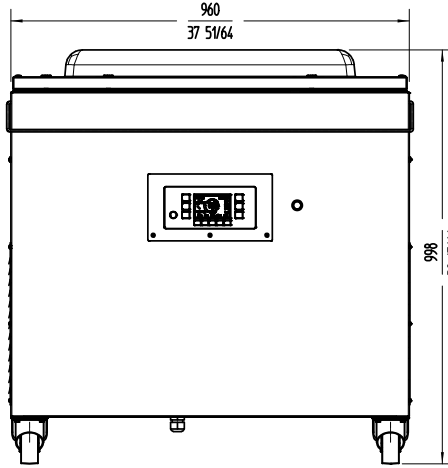

AVAILABLE VERSIONS

1140935 Vacuum packing machine SU-810 230-400/50/3N

* ask for special versions availability

ACCESORIES

- Bag cutting kits
- Filling plates
- Liquid insert plates
- Vac-norm external vacuum kits
- Vac-norm containers
- Smooth bags for vacuum packing
- CG2 Desktop printer for SU vacuum packing machines *
- Thermal labels for CG2 printer

FOOD PRESERVATION AND SOUS-VIDE
VACUUM PACKING MACHINES - "SENSOR ULTRA" LINE

sammic | www.sammic.com
 Food Service Equipment Manufacturer

Polígono Basarte, 1. phone +34 943 15 72 36
 20720 Azkoitia, Spain sales@sammic.com



Project	Date
Item	Qty
Approved	

specification sheet
update 11/21/17