



VACUUM PACKING MACHINE SU-310GP 230/50-60/1

Tabletop model. 10 m³/h. 320 mm.



P/N 1140733



FEATURES AND BENEFITS

- ✓ Powered by Busch.
- ✓ Vacuum controlled by sensor.
- ✓ Vacuum PLUS.
- ✓ LCD colour screen: all information at a glance.
- ✓ Backlit touch keyboard.
- ✓ Programmable: 25-programme memory. Blocking option.
- ✓ "Pause" button.
- ✓ Phased vacuum programme.
- ✓ Detection of the evaporation of liquids.
- ✓ Double seal.
- ✓ Cordless sealing bar.
- ✓ Progressive decompression.
- ✓ Vac-Norm ready with Automatic decompression.
- ✓ Stainless steel body and chamber. Deep-drawn chamber.
- ✓ Damped transparent lid of high durability polycarbonate.
- ✓ Dry-oil programme for drying the pump.
- ✓ Working hours counter for oil changes.
- ✓ Safety system with protection against vacuum failure.
- ✓ NSF-listed model.

SALES DESCRIPTION

- 320 mm. sealing bar.
- 10 m³/h Busch vacuum pump.
- Vacuum controlled by sensor.

INCLUDES

- ✓ Filling plate
- ✓ Inert gas flush
- ✓ Bluetooth connectivity
- ✓ Printer connection

ACCESSORIES

- Filling plates
- Liquid insert plates
- Vac-norm external vacuum kits
- Vac-norm containers
- Smooth bags for vacuum packing
- CG2 Desktop printer for SU vacuum packing machines *
- Thermal labels for CG2 printer
- RB Desktop printer for SU vacuum packing machines *
- Thermal transfer labels for printer



sammic | www.sammic.com
Food Service Equipment Manufacturer

Polígono Basarte, 1. phone +34 943 15 72 36
20720 Azkoitia, Spain sales@sammic.com



Project	Date
Item	Qty
Approved	

FOOD PRESERVATION AND SOUS-VIDE
VACUUM PACKING MACHINES - "SENSOR ULTRA" LINE

product sheet
updated 30/05/2019



VACUUM PACKING MACHINE SU-310GP 230/50-60/1

Tabletop model. 10 m³/h. 320 mm.



P/N 1140733

SPECIFICATIONS

Pump capacity: 10 m³/h

Bar length: 320 mm

Total loading: 370 W

Vacuum pressure (maximum): 2 mbar

Electrical supply: 230 V / 50-60 Hz / 1 ~
(3.4 A)

Internal dimensions

✓ Width: 330 mm

✓ Depth: 360 mm

✓ Height: 155 mm

External dimensions (WxDxH)

✓ Width: 384 mm

✓ Depth: 465 mm

✓ Height: 403 mm

Net weight: 39.5 Kg

Noise level (1m.): 75 dB(A)

Background noise: 32 dB(A)

Crated dimensions

460 x 530 x 460 mm

Gross weight: 43.5 Kg.

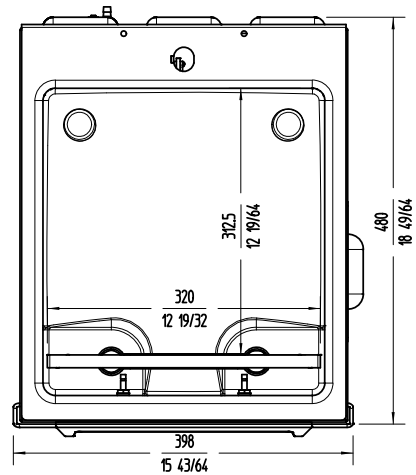
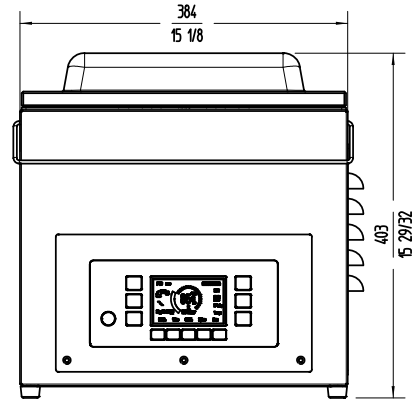
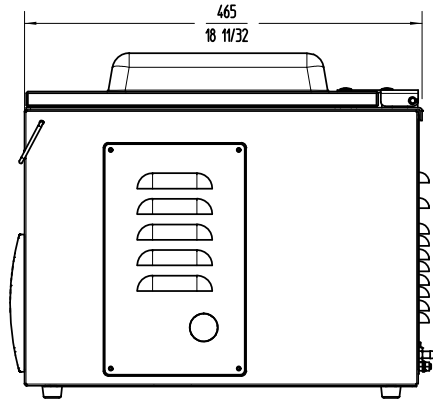

FOOD PRESERVATION AND SOUS-VIDE
VACUUM PACKING MACHINES - "SENSOR ULTRA" LINE

sammic | www.sammic.com
Food Service Equipment Manufacturer

Polígono Basarte, 1. phone +34 943 15 72 36
20720 Azkoitia, Spain sales@sammic.com



Project	Date
Item	Qty
Approved	

product sheet
updated 30/05/2019