

BM740TT

Bain Marie - Electric, 2/1 GN / Countertop

700



Product Information:

- Class leading, European style, professional quality and reliability since 1963
- 700 series, electric 2/1 GN countertop Bain Marie (2.4kW)
- Silicone heating pad external to the tank provides uniform heating, superior hygiene and ease of cleaning
- Temperature regulation via thermostat (30°C - 90°C)
- Indicator lights to monitor the correct operation of the appliance
- Manual water fill with tank sloped to solenoid valve operated drain
- Robust 304 grade stainless steel construction with rounded corners for improved cleaning
- 24-month warranty

General Drawing:

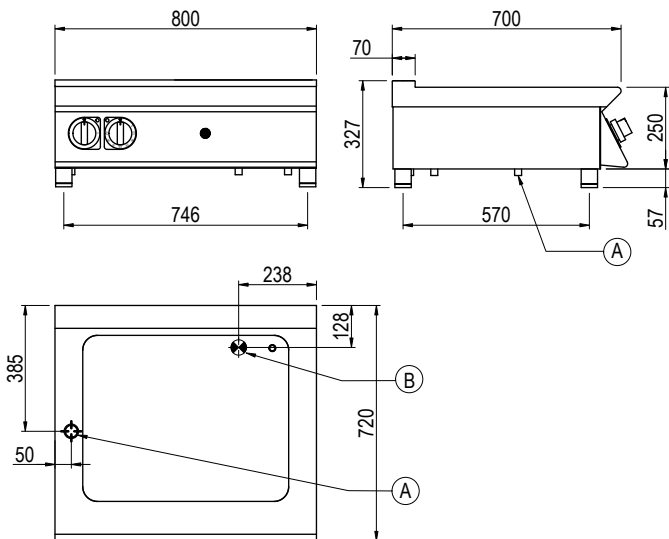

Specifications:

Model	BM740TT
W x D x H (mm)	800 x 720 x 327
Weight	75kg
Capacity	1 x 2/1 150mm GN Pans
Packed Dimensions (mm)	845 x 825 x 570
Packed Weight	85kg
Electrical Connection	1Ø + N + E 240VAC / 50Hz / 2.4kW 10A plug & lead fitted

Legend:

- A** Electrical Connection
- B** Drain Connection 1/2" BSP

Due to continuous product research and development, the information contained herein is subject to change without notice.

Revision: 01 - 04/01/2022 - A

www.stoddart.com.au

www.stoddart.co.nz

