

specifications

PG500HFr

SKOPE Pegasus Horizontal 2/1
REMOTE 2 Door Freezer (JK5302)

CABINET DIMENSIONS

	External	Internal
Height:	771mm*	565mm
Width:	1750mm	1250mm
Depth:	828mm	650mm
Floor area:	1.45m ²	

* Height includes plinth and worktop (excludes castors and adjustable legs).

**INDUSTRY
KITCHENS**

www.industrykitchens.com.au 1800 611 058

Pictured with optional 50mm stainless steel worktop

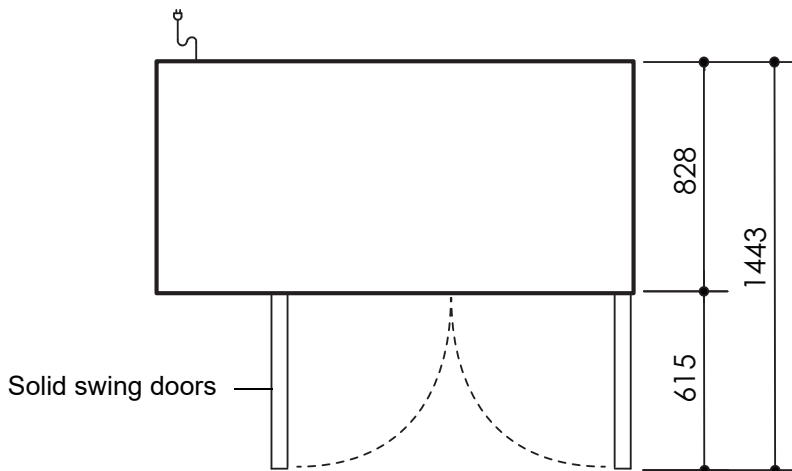

Electronic controller

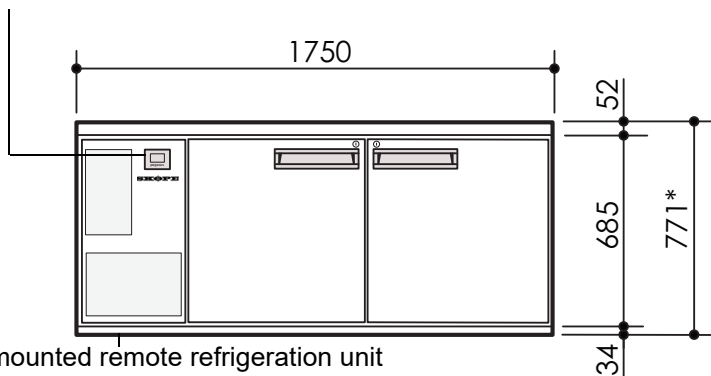

Side mounted remote refrigeration unit

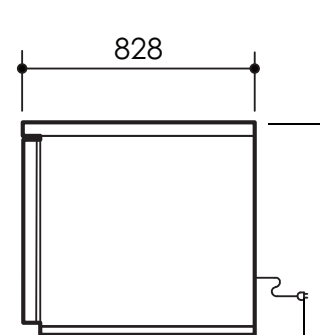

Power cord with 3-Pin plug

Copyright © 2012 SKOPE Industries Limited

CABINET SPECIFICATIONS

Refrigeration system:	Electronic controlled, side mounted, remote refrigeration unit
Refrigerant:	Thermostatic expansion valve fitted as standard to suit R404A
Pipe connection size:	Liquid line: 1/4". Suction line: 3/8"
Remote refrigeration duty:	364 Watts @ -30°C SST
Cabinet internal volume:	480 litres
Insulation:	60mm thick, high density cyclo-isopentane polyurethane foam
Cabinet temperature range:	-18°C to -21°C up to 43°C ambient
Drainage:	Evaporator drain fitted inside service compartment (requires plumbing)
Electrical:	230-240 Volts a.c. 50 Hz, 3.60 Amps
Internal lighting:	n.a.
Internal door opening size:	2 door openings: 565mm high x 565mm wide
Door:	Solid stainless steel, self-closing doors (with key lock) - LH & RH hinged
Worktop (optional):	Optional 50mm square edged stainless steel worktop
Shelves:	Two levels of non-tip, adjustable tray slides and/or shelves per door
Weight:	123 kg

SKOPE Industries Limited reserve the right to alter specifications without notice.

PSS0319 Rev 2.3 Aug. 2017



SKOPE INDUSTRIES LIMITED



New Zealand Freephone: 0800 947 5673, Fax: (03) 983 3896. Australian Freephone: 1800 121 535, Freefax: 1800 121 533

Email: enquiry@skope.co.nz Website: www.skope.co.nz