

specifications

PG500Prepr

SKOPE Pegasus Horizontal 2/1
REMOTE 2 Door Prep Chiller (JK8302)

CABINET DIMENSIONS

	External	Internal
Height:	771mm*	495mm
Width:	1750mm	1250mm
Depth:	828mm	650mm
Floor area:	1.45m ²	

* Height includes plinth and worktop (excludes castors and adjustable legs).

**INDUSTRY
KITCHENS**

www.industrykitchens.com.au 1800 611 058

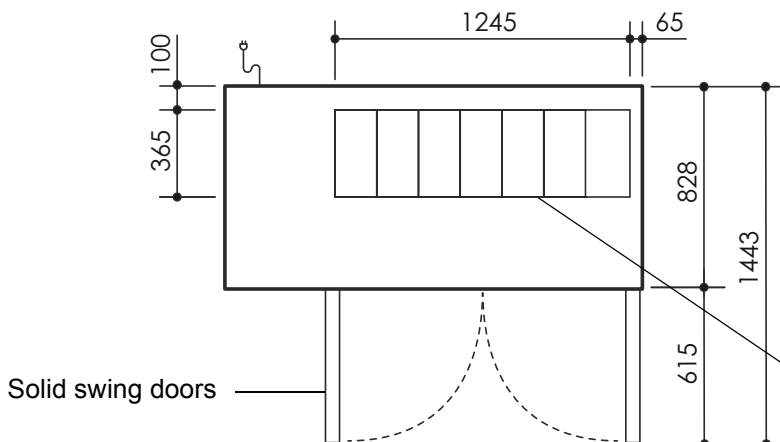

Electronic controller

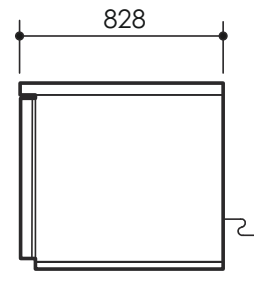
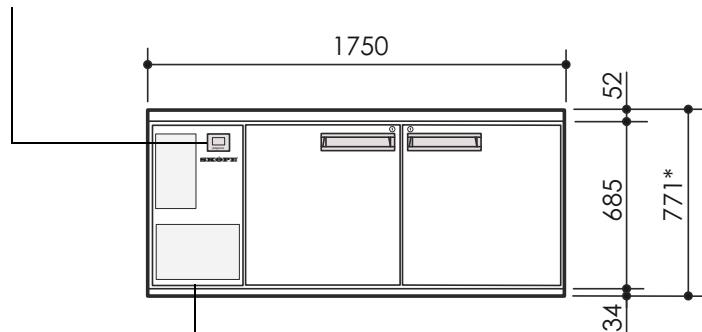

Side mounted remote refrigeration unit

Copyright © 2012 SKOPE Industries Limited

CABINET SPECIFICATIONS

Refrigeration system:	Electronic controlled, side mounted, remote refrigeration unit
Refrigerant:	Thermostatic expansion valve fitted as standard to suit R134a or R404A
Pipe connection size:	Liquid line: 1/4". Suction line: 3/8"
Remote refrigeration duty:	706 Watts @ -10°C SST
Cabinet internal volume:	480 litres
Insulation:	60mm thick, high density cyclo-isopentane polyurethane foam
Cabinet temperature range:	+1°C to +5°C up to 30°C ambient
Drainage:	Evaporator drain fitted inside service compartment (requires plumbing)
Electrical:	230-240 Volts a.c. 50 Hz, 0.49 Amps
Internal lighting:	n.a.
Internal door opening size:	2 door openings: 565mm high x 565mm wide
Doors:	Solid stainless steel, self-closing doors (with key lock) - LH & RH hinged
Worktop:	Worktop accepts 7 x 1/3 150mm deep pans
Shelves:	2 shelves & adjustable tray slides per door (530mm wide x 650mm deep)
Weight:	135 kg

SKOPE Industries Limited reserve the right to alter specifications without notice.

PSS0233 Rev. 4.3 Apr. 2016



SKOPE INDUSTRIES LIMITED



New Zealand Freephone: 0800 947 5673, Fax: (03) 983 3896. Australian Freephone: 1800 121 535, Freefax: 1800 121 533

Email: enquiry@skope.co.nz Website: www.skope.co.nz