

Electric salamander broiler with dual controlled Solar Ray heating elements. All Stainless steel construction, 34" (864mm) wide with fixed position broiling rack. Available wall mounted or counter mounted.

STANDARD FEATURES

- Stainless steel exterior
- Six metal sheath elements, 3 over each half of broiler rack, 1.16 kW each, (3.5 kW per side, 7.0 kW total)
- Elements are controlled by two 3-heat switch controls, one for each half of the broiler rack
- Fixed position broiling rack with flat or easy view tilt position, roll-in, roll-out rack
- Large capacity removable grease pan
- Heat resistant, cool touch handle with easy grip shape
- 102mm sanitary legs

OPTIONAL FEATURES

- Stainless steel wall-mount brackets, please specify when ordering
- Stainless steel main back

DIMENSIONS

External Dimension: 864W x 457D x 413H mm

Clearance: Sides: 178mm, Back: 51mm

TECHNICAL DATA

Power supply: 415V, 2 Phase, 50Hz

Total Output: 7kW

Shipping weight: 95kg

SPECIFICATIONS ARE SUBJECT TO CHANGE WITHOUT NOTICE.

SERC

864mm WIDE ELECTRIC SALAMANDER

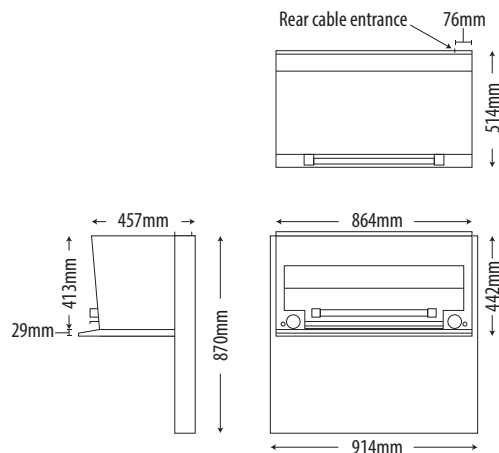

INDUSTRY
KITCHENS

www.industrykitchens.com.au 1800 611 058



National Head Office
156 Swann Drive
Derrimut VIC 3030
Tel: +61 3 8369 4600
Fax: +61 3 8369 4699

www.comcater.com.au

Melbourne
96-100 Tope Street
South Melbourne VIC 3205
Tel: +61 3 8369 4600
Fax: +61 3 8699 1299

Sydney
20/4 Avenue of the Americas
Newington, NSW 2127
Tel: +61 2 9748 3000
Fax: +61 2 9648 4762

Brisbane
1/62 Borthwick Avenue
Murarrie QLD 4172
Tel: +61 7 3399 3122
Fax: +61 7 3399 5311

Perth
Unit 16, 7 Abrams Street
Balcatta, WA 6021
Tel: +61 8 6217 0700
Fax: +61 8 6217 0799