



CUTLERY DRYER SAS-6001 230/50/1

Floorstanding machine with motor brake and outlet fan.



WARE WASHING
CUTLERY DRYERS

P/N 1370044



FEATURES AND BENEFITS

- ✓ Dries, polishes and removes lime scale stains from cutlery after washing.
- ✓ Fully automatic.
- ✓ Stainless steel body and polishing tank.
- ✓ Rounded cutlery carousel, avoiding cutlery jams.
- ✓ Economy: saves on personnel costs and quick return of investment.
- ✓ Speed: hourly output of up to 8,000 pieces.
- ✓ Hygiene: the germicidal UVC-ray lamp sterilises both the cutlery and the polishing product.

SALES DESCRIPTION

Output: up to 8000 pieces per hour.

INCLUDES

- ✓ Germicidal UVC-ray lamp.
- ✓ Outlet fan.
- ✓ Motor brake.

ACCESSORIES

- Polishing product
- Front Wheel Kit



sammic | www.sammic.com
Food Service Equipment Manufacturer

Polígono Basarte, 1. phone +34 943 15 72 36
20720 Azkoitia, Spain sales@sammic.com



Project	Date
Item	Qty
Approved	

product sheet
updated 17/04/2019



CUTLERY DRYER SAS-6001 230/50/1

Floorstanding machine with motor brake and outlet fan.



P/N 1370044

SPECIFICATIONS

Hourly production (pieces): 5000 - 8000
 Electrical supply: 230 V / 50 Hz / 1 ~ (5.2 A)
 Plug: EU

Loading

- ✓ Motor power: 300 W
- ✓ Element power: 900 W
- ✓ Uvc lamp power: 8 W
- ✓ Fan power: 50 W

External dimensions (WxDxH)

- ✓ Width: 630 mm
- ✓ Depth: 693 (800) mm
- ✓ Height: 783 mm

Net weight: 130 Kg

Crated dimensions

760 x 850 x 930 mm

Gross weight: 142 Kg.

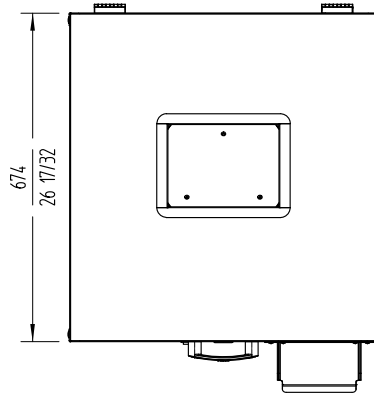
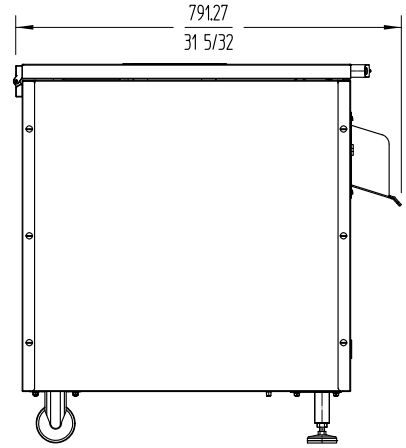
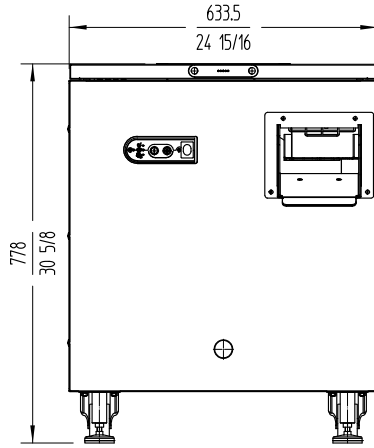

WARE WASHING
CUTLERY DRYERS

sammic | www.sammic.com
 Food Service Equipment Manufacturer

Polígono Basarte, 1. phone +34 943 15 72 36
 20720 Azkoitia, Spain sales@sammic.com



Project	Date
Item	Qty
Approved	

product sheet
updated 17/04/2019