

1524mm WIDE 10 ELEMENT ELECTRIC RANGE

The state-of-the-art Garland Heavy Duty Electric Series is a commercial range that has been engineered for unmatched performance and durability.

The Heavy Duty Electric Series is built to last well into the future. It is also built to suit specified requirements. Each 305mm section of this series can be customised to fit the available kitchen space and workflow.

Featuring stainless steel construction with a 87mm front 'plate rail' and 254mm backguard that matches the other Electric Series units giving a sleek clean finish and can be lined up with the 152mm high adjustable stainless steel legs.

10 all-purpose tubular electric elements in 2 sizes with the option of sealed high performance elements designed for small pot work are controlled by an infinite switch.

Large easy-to-use control knobs sit atop the fully porcelain interior standard oven that accepts full sized sheet pans in both directions on a 4-position removable rack guide, has a 4.85kW element and electro-mechanical heavy duty thermostat 66°C - 288°C and a strong adjustable door with heat resistant, cool touch door handle.

OPTIONAL FEATURES

- Additional Oven Rack
- Swivel casters with front brakes
- Convection oven base (add suffix - RC) Note: Convection oven comes standard with 2 oven racks
- Sealed high performance elements with 6-heat switch (Model SS684) Note: Sealed elements are not available with all-purpose tubular elements. All top elements must be the same type.
- Marine equipment - storm rails for pots, oven door latch, drip tray stop and deck fasteners



DIMENSIONS

External Dimension: 1524W x 794D x 1190H mm
 Working height: 955mm
 Oven Interior : 667W x 559D x 343H mm

TECHNICAL DATA

Power supply: 415V, 3 Phase, 50Hz
 Total Output: 26.45kW

Element Ratings:		
Tubular Element:	165mm	216mm
	1.25kW	2.1kW
Sealed High Performance Elements:	180mm	220mm
	2.0kW	2.6kW
Griddle per 300mm section:	3.35kW	
Standard Oven:	4.85kW	
Convection Oven:	5.5kW	

Shipping weight: 285kg

SPECIFICATIONS ARE SUBJECT TO CHANGE WITHOUT NOTICE.

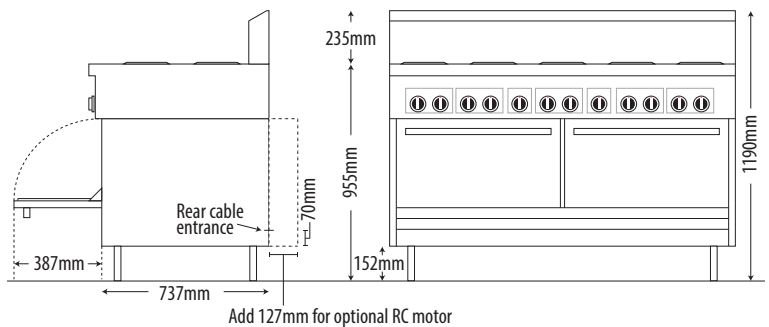
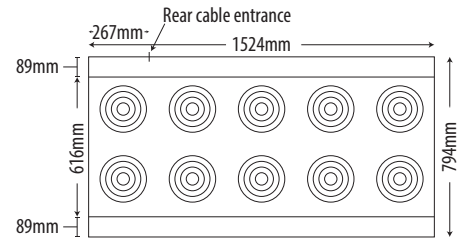

INDUSTRY KITCHENS

www.industrykitchens.com.au 1800 611 058



National Head Office
 156 Swann Drive
 Derrimut VIC 3030
 Tel: +61 3 8369 4600
 Fax: +61 3 8369 4699
www.comcater.com.au

Melbourne
 96-100 Tope Street
 South Melbourne VIC 3205
 Tel: +61 3 8369 4600
 Fax: +61 3 8699 1299

Sydney
 20/4 Avenue of the Americas
 Newington, NSW 2127
 Tel: +61 2 9748 3000
 Fax: +61 2 9648 4762

Brisbane
 1/62 Borthwick Avenue
 Murarrie QLD 4172
 Tel: +61 7 3399 3122
 Fax: +61 7 3399 5311

Perth
 Unit 16, 7 Abrams Street
 Balcatta, WA 6021
 Tel: +61 8 6217 0700
 Fax: +61 8 6217 0799