

Rowlett

Toaster

Instruction manual



Model:
Premier/Regent/Esprit

Safety Instructions

Please take a few moments to carefully read through this manual. Correct maintenance and operation of this machine will provide the best possible performance from your Rowlett product.

- Position on a flat, stable surface.
- A service agent/qualified technician should carry out installation and any repairs if required. Do not remove any components on this product.
- Consult Local and National Standards to comply with the following:
 - Health and Safety at Work Legislation
 - Fire Precautions
 - Wiring Regulations
 - Building Regulations
- **This is an Attended Appliance.**
- **Caution: Hot surfaces!**
- **Danger of burns!** 
DO NOT touch the top and sides of the appliance when in use.
- DO NOT immerse the appliance in water.
- DO NOT obstruct or cover the appliance in any way when in use.
- DO NOT insert any metallic objects in to the appliance when connected to a power supply.
- Always switch off the appliance, disconnect the power supply and allow to cool before cleaning, carrying out maintenance, or when not in use.
- Keep all packaging away from children. Dispose of the packaging in accordance to the regulations of local authorities.
- DO NOT use if damaged.
- This appliance can be used by children aged from 8 years and above and persons with reduced physical, sensory or mental capabilities or lack of experience and knowledge if they have been given supervision or instruction concerning use of the appliance in a safe way and understand the hazards involved.
- Children shall not play with the appliance.

- Cleaning and user maintenance shall not be made by children without supervision.
- Keep the appliance and its cord out of reach of child less than 8 years.
- This appliance is not intended to be operated by means of an external timer or separate remote-control system.
- **Fire hazard! Bread can burn!**  The appliance should not come into contact or be covered with easily flammable materials, like curtains, textiles, walls and the like. Always ensure sufficient safety distance to flammable materials.
- This appliance is intended to be used in household and similar applications such as:
 - staff kitchen areas in shops, offices and other working environments;
 - farm houses;
 - by clients in hotels, motels and other residential type environments;
 - bed and breakfast type environments.
- Rowlett recommend that this appliance should be periodically tested (at least annually) by a Competent Person. Testing should include, but not be limited to: Visual Inspection, Polarity Test, Earth Continuity, Insulation Continuity and Functional Testing.

Introduction

Engineered for reliability, Rowlett toaster range enjoys huge success in pubs, restaurants, leisure outlets, hotels, institutions and caring establishments. Select from a wide choice of Bread toasters available with variable settings for toasting perfection.

Pack Contents

The following is included:

- Toaster
- Instruction manual
- Sandwich cage: For Esprit range only (Models CH177-A to CH188-A)
- Replacement element set AL994 (1 x AK232 Middle element, 1 x AK231 End element)

Rowlett prides itself on quality and service, ensuring that at the time of packaging the contents are supplied fully functional and free of damage.

Should you find any damage as a result of transit, please contact your Rowlett dealer immediately.

Operation



Toasting

1. Remove the appliance from the packaging. Make sure that all protective plastic film and plastic coatings are thoroughly removed from all surfaces.
2. Ensure the Timer knob is set to 'OFF'.

Note: There is no separate on/off switch on the toaster as it forms part of the timer mechanism. Your toaster is "off" when the timer knob is set to "OFF". Ensure your toaster is plugged in before turning it on.

3. The slot selector knob is used to determine which slots are energised.

Note: All Rowlett toasters (excluding 2-slot toasters) have a slot selector knob that enables you to control which slots are in use, saving on element wear and electricity. Choose how many slots you need and adjust the selector knob accordingly. Slots are energised from the left.

4. Load bread into toaster with ejector lever up. Lower to toast. Do not use bread that is too thick.
5. Set the timer knob to desired time setting according to your taste. It is better to use 1 day old bread.
6. The power indicator light will illuminate and the timer will start.
7. Power will be automatically turned off shortly before the timer completes its task.
8. The toast can be removed immediately by using the ejector lever, or left in the machine to keep warm for several minutes.

Cleaning, Care & Maintenance

Always switch off the appliance, disconnect the power supply and allow to cool before cleaning or performing maintenance.

- If necessary wipe the exterior with a soft cloth and warm soapy water.
- Never use a scouring agent as this will scratch the finish.
- Dry thoroughly after cleaning.

Crumb Tray

- Periodically empty the crumb tray (located at the bottom of the appliance).
- Slide the tray out to empty.
- Slot back in securely when replacing the tray.

Notes on maintenance

- Bread containing fruit or nuts can be toasted but natural sugars present may cause them to stick to the guard rails on your toaster. Such debris should not be left on the guard rails as it will char and possibly smoke and can swell so as to damage the element.
- Elements wear out with use and it is impossible to predict their life as this is affected by the amount and type of use and the quality of electrical supply. They can easily be damaged by careless handling. Your toaster has been designed that should anything go wrong all major components such as elements and switches can easily be replaced.
- Repairs or replacement of components should be undertaken only by a competent electrician.
- All components and fitting instructions can be obtained from your supplier.

Troubleshooting

If your Rowlett appliance develops a fault, please check the following table before making a call to the Helpline. A Rowlett agent or qualified technician must carry out repairs if required.

Fault	Probable Cause	Solution
The unit is not working	The unit is not switched on	Check the unit is plugged in correctly and switched on
	Plug or lead is damaged	Replace plug or lead
	Mains power supply fault	Check mains power supply
	Heating element has expired	Refer to replacing instructions (on Pages 7-8)
	Thermal cut-out activated	Check your machine is safe with no obvious damage. Disconnect from power supply and let it cool down, then remove the bottom cover and press the re-set switch (white-coloured)

Electrical Wiring

The plug is to be connected to a suitable mains socket.

This appliance is wired as follows:

- Live wire (coloured brown) to terminal marked L
- Neutral wire (coloured blue) to terminal marked N
- Earth wire (coloured green/yellow) to terminal marked E

This appliance must be earthed.



If in doubt consult a qualified electrician.

Electrical isolation points must be kept clear of any obstructions. In the event of any emergency disconnection being required they must be readily accessible.

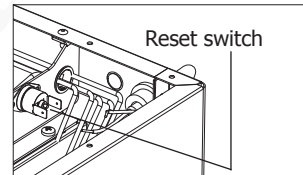

Compliance

The product must not be disposed of as household waste. To help prevent possible harm to human health and/or the environment, the product must be disposed of in an approved and environmentally safe recycling process. For further information on how to dispose of this product correctly, contact the product supplier, or the local authority responsible for waste disposal in your area.

EAZYZAP parts have undergone strict product testing in order to comply with regulatory standards and specifications set by international, independent, and federal authorities.

EAZYZAP products have been approved to carry the following symbol:



All rights reserved. No part of these instructions may be produced or transmitted in any form or by any means, electronic, mechanical, photocopying, recording or otherwise, without the prior written permission of Rowlett.

Every effort is made to ensure all details are correct at the time of going to press, however, Rowlett reserves the right to change specifications without notice.

Technical Specifications

Model	Voltage	Power	Slots	H x W x D mm	Weight (Kg)
CH170-A: Stainless steel	220-240V~, 50-60Hz	1800W	4	210 x 410 x 210	6.00
CH181-A: Chrome					
CH182-A: White					
CH183-A: Jet Black					
CH184-A: Traffic Red					
CH172-A: White					6.50 kg
CH173-A: Jet Black					
CH174-A: Quartz Grey					
CH175-A: Traffic Red					
CH171-A: Stainless steel		2600W	6	210 x 500 x 210	7.50 kg
CH185-A: Chrome					
CH186-A: White					
CH187-A: Jet Black					
CH188-A: Traffic Red					
CH176-A: White					8.50 kg
CH177-A: Chrome		1000W	2	200 x 310 x 210	4.50
CH178-A: White					
CH179-A: Jet Black					
CH180-A: Traffic Red					

Replacing the heating element AL994



Before taking action, ensure to identify the damaged heating element, then disconnect toaster from power supply and let it cool down sufficiently. Element replacement to be conducted by an electrically competent person!

Tools needed (not supplied)

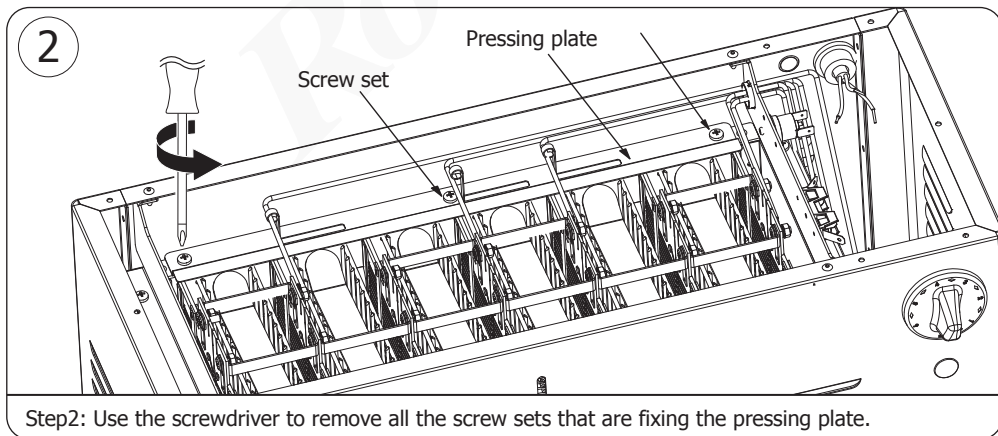
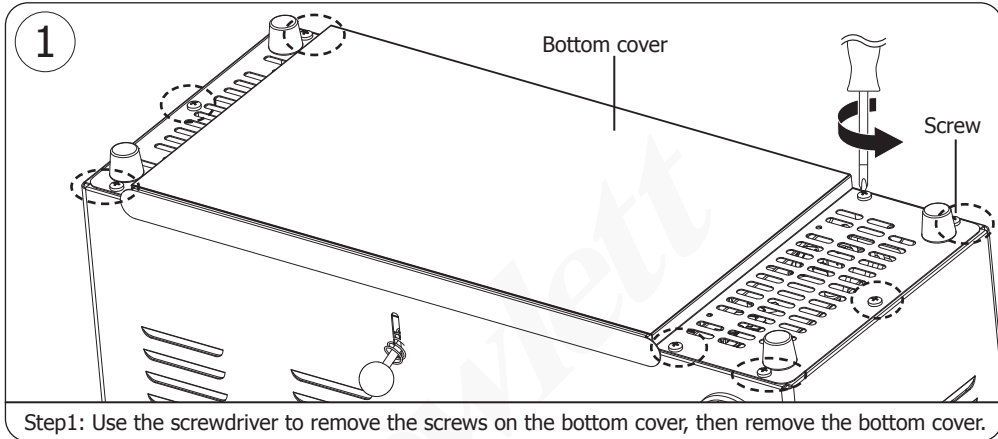
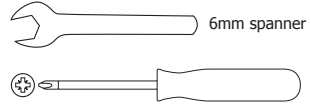

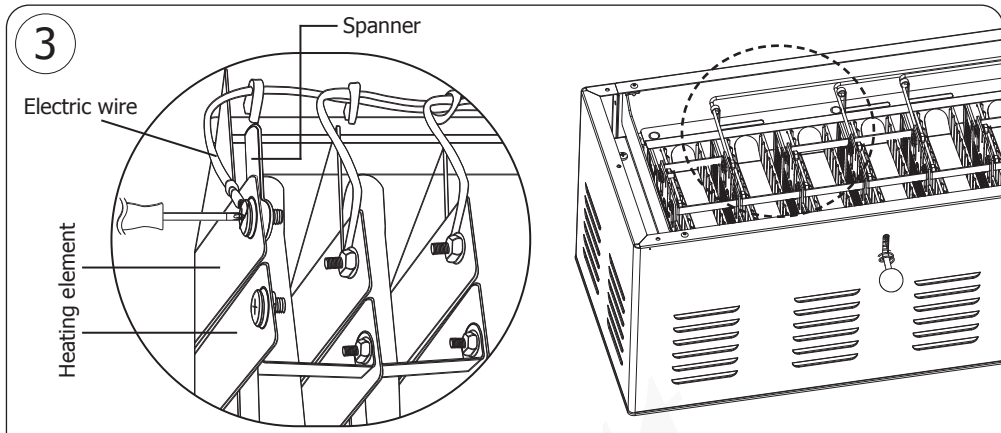

Step3: Lift the damaged heating element. Then use the spanner to hold the nut whilst using the screwdriver to loosen the screw, thus the heating element can be released.

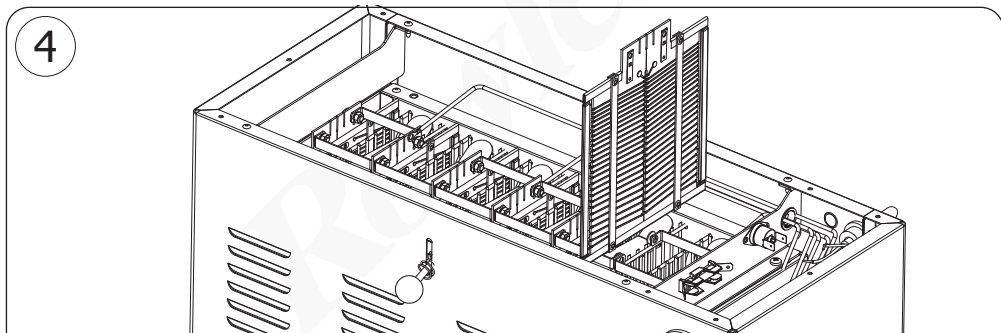

Step4: Take out the damaged heating element.

Step5: Insert a new heating element into the slot, then mount the electric wire and heating element in place with the previously removed nuts and screws.

Step6: Install back the previously removed pressing plate and bottom cover with the screws.

DECLARATION OF CONFORMITY

- Conformiteitsverklaring • Déclaration de conformité • Konformitätserklärung • Dichiarazione di conformità •
• Declaración de conformidad • Declaração de conformidade

Equipment Type • Uitrustingstype • Type d'équipement • Gerätetyp • Tipo di apparecchiatura • Tipo de equipo • Tipo de equipamento			Model • Modèle • Modell • Modello • Modelo • Mali			
	2 Slot	4 Slot	6 Slot	2 Slot	4 Slot	6 Slot
Premier	Stainless Steel				CH170 (&-A)	CH171 (&-A)
	Quartz Grey				CH174 (&-A)	
Regent	Jet Black				CH173 (&-A)	
	Traffic Red				CH175 (&-A)	
	White				CH172 (&-A)	CH176 (&-A)
Esprit	Chrome			CH177 (&-A)	CH181 (&-A)	CH186 (&-A)
	White			CH178 (&-A)	CH182 (&-A)	CH187 (&-A)
	Jet Black			CH179 (&-A)	CH183 (&-A)	CH188 (&-A)
	Traffic Red			CH180 (&-A)	CH184 (&-A)	CH185 (&-A)
Application of Territory Legislation & Council Directives(s) Toepassing van Europese Richtlijn(en) • Application de la/des directive(s) du Conseil • Anwendbare EU-Richtlinie(n) • Applicazione delle Direttive • Aplicación de la(s) directiva(s) del consejo • Aplicação de directiva(s) do Conselho	Low Voltage Directive (LVD) - 2014/35/EU Electrical Equipment (Safety) Regulations 2016 EN 60335-1:2012 +A11:2014 +A13:2017 EN 60335-2-9:2003 +A1:2004 +A2:2006 +A12:2007 +A13:2010 +AC:2012 EN 62233:2008 Electro-Magnetic Compatibility (EMC) Directive 2014/30/EU - recast of 2004/108/EC Electromagnetic Compatibility Regulations 2016 (S.I. 2016/1091) EN55014-1:2017 EN55014-2:2015 EN 61000-3-2: 2014 EN 61000-3-3: 2013 Restriction of Hazardous Substances Directive (RoHS) 2015/863 amending Annex II to Directive 2011/65/EU Restriction of the Use of Certain Hazardous Substances in Electrical and Electronic Equipment Regulations 2012 (S.I. 2012/3032)			Electrical Safety AS/NZS 60335.1:2011 +A1:2012 +A2:2014 +A3:2015 +A4:2017 AS/NZS:60335.2.9:2014 +A1:2015 +A2:2016 +A3:2017 Electromagnetic Compatibility EN55014-1:2017 EN55014-2:2015 EN 61000-3-2: 2014 EN 61000-3-3: 2013		
Producer Name • Naam fabrikant • Nom du producteur • Name des Herstellers • Nome del produttore • Nombre del fabricante • Nome do fabricante			Rowlett			

I, the undersigned, hereby declare that the equipment specified above conforms to the above Territory Legislation, Directive(s) and Standard(s).
 Ik, de ondergetekende, verklaar hierbij dat de hierboven gespecificeerde uitrusting goedgekeurd is volgens de bovenstaande Richtlijn(en) en Standaard(en).
 Je soussigné, confirme la conformité de l'équipement cité dans la présente à la / aux Directive(s) et Norme(s) ci-dessus.
 Ich, der/die Unterzeichnende, erkläre hiermit, dass das oben angegebene Gerät der/den oben angeführten Richtlinie(n) und Norm(en) entspricht.
 Il sottoscritto dichiara che l'apparecchiatura di sopra specificata è conforme alle Direttive e agli Standard sopra riportati.
 El abajo firmante declara por la presente que el equipo arriba especificado está en conformidad con la(s) directiva(s) y estándar(es) arriba mencionadas.
 Eu, o abaixo-assinado, declaro que o equipamento anteriormente especificado está em conformidade com a(s) anterior(es) Directiva(s) e Norma(s)

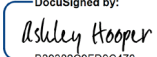
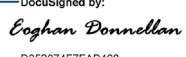
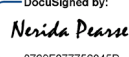
Date • Data • Datum • Data • Fecha • Data	2 nd November 2021		
Signature • Handtekening • Signature • Unterschrift Firma • Firma • Assinatura	DocuSigned by:  B39382C9FD9C478...	DocuSigned by:  D3528747FFAB460...	DocuSigned by:  8769F077756845D...
Full Name • Volledige naam • Nom et prénom • Vollständiger Name • Nome completo • Nombre completo • Nome por extenso	Ashley Hooper	Eoghan Donnellan	Nerida Pearse
Position • Functie • Fonction • Position • Qualifica • Posición • Função	Technical & Quality Manager	Commercial Manager/ Importer	Commercial Manager/ Responsible Supplier
Producer Address • Adres fabrikant • Adresse du producteur • Anschrift des Herstellers • Indirizzo del produttore • Dirección del fabricante • Morada do fabricante	Fourth Way, Avonmouth, Bristol, BS11 8TB United Kingdom	42 North Point Business Park New Mallow Road Cork Ireland	15 Bagdally Road, Campbelltown NSW 2560



Rowlett

Rowlett Toaster IM_ANZ_A5_v2_20211207