

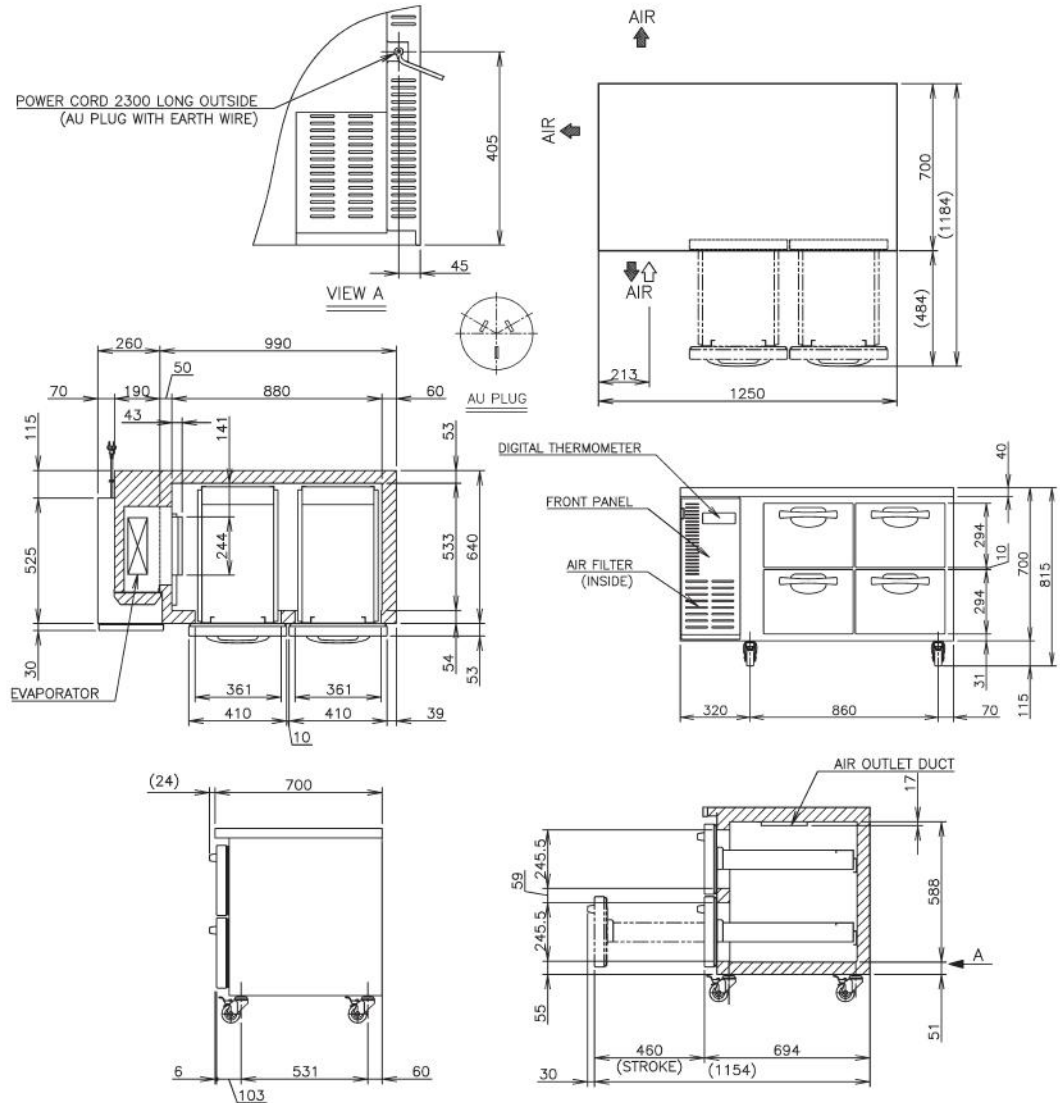

## PRODUCT FEATURES

- Stainless steel interior and exterior.
- Programmable Digital controller and display.
- 4 x Auto closing drawers
- Fits GN pans 150mm Deep
- Compact slide out refrigeration unit for quick maintenance.
- 2 years parts and labour warranty.
- Comes standard with 115mm lockable castors (not legs).
- Optional Adjustable legs 150 - 180mm (Sold separately).

## TECHNICAL DRAWING



## PRODUCT SPECIFICATION

Exterior	Stainless Steel, Galvanized Steel (Rear /Bottom)
Interior	Stainless Steel, ABS Plastic
Max Storage Capacity	270L
Temperature Control	Microprocessor controlled Adjustable from -6 to 12°C
Drain Evaporator Pan	Fin & Tube type
Outside Dimensions	1250mm (W) x 700mm (D) x 815mm (H)
Inside Dimensions	880mm (W) x 533mm (D) x 588mm (H)
Refrigeration System	Forced Air Circulation
Weight Net/Gross (kg)	101
AC Supply Voltage	1 PHASE 220-240V 50Hz/10amp Plug
Amperage	Rated: 2.2A
Refrigerant	R134a / 150g
Operating Conditions	Ambient Temp.: 5-43°C Voltage Range: Rated Voltage ±6%

