



RB100

ICE STORAGE BIN WITH TROLLEYS

The RB100 is a stainless steel structure with a 108kg capacity polyethylene moulded trolley for transporting ice flakes.

When coupled with an ice flake head, the RB100 generously stores ice to meet peak demand times for a range of applications.

Can be coupled with: VM500/900, TM250/450, G280/510.

STANDARD FEATURES

- 108kg storage capacity
- Can be coupled with a range of Brema modular ice machine heads
- Stainless steel structure
- Polyethylene moulded trolleys

STANDARD ACCESSORIES

- Drainage hose
- Plastic Ice Scoop



DIMENSIONS	
795W x 1060D x 1284H mm	
Clearances: Rear: 100mm Sides: 100mm	
CONNECTIONS	
24mm Water outlet	
TECHNICAL DATA	
Store Capacity:	17kg
Storage Capacity:	108kg
Weight:	64kg
USABLE WITH MODULAR HEADS	
TM250/450, G280/510, G160/280/510	

SPECIFICATIONS ARE SUBJECT TO CHANGE WITHOUT NOTICE.

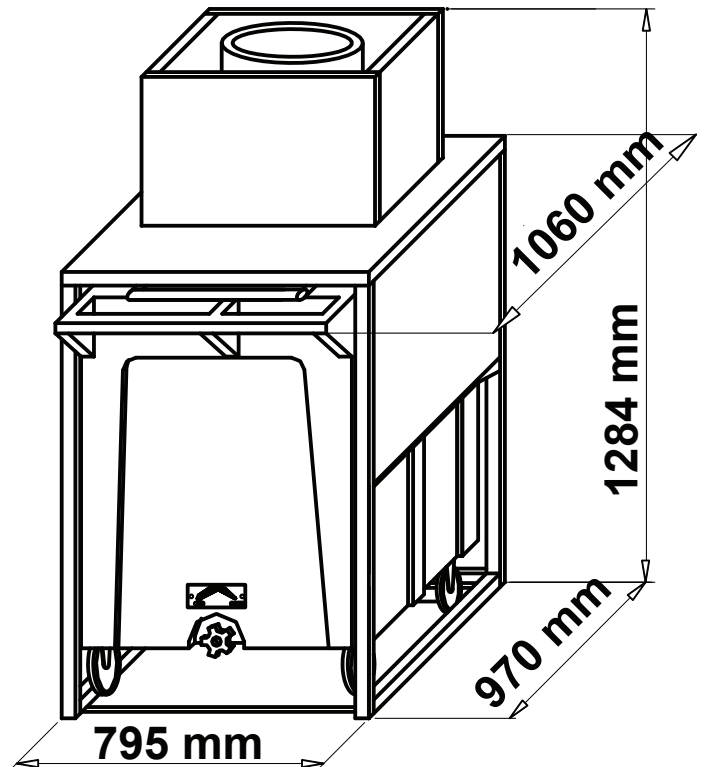

National Head Office
156 Swann Drive
Derrimut VIC 3030
Tel: +61 3 8369 4600
Fax: +61 3 8369 4699
www.comcater.com.au

Melbourne
96-100 Tope Street
South Melbourne VIC 3205
Tel: +61 3 8369 4600
Fax: +61 3 8699 1299

Sydney
20/4 Avenue of the Americas
Newington, NSW 2127
Tel: +61 2 9748 3000
Fax: +61 2 9648 4762

Brisbane
1/62 Borthwick Avenue
Murarrie QLD 4172
Tel: +61 7 3399 3122
Fax: +61 7 3399 5311

Perth
Unit 16, 7 Abrams Street
Balcatta, WA 6021
Tel: +61 8 6217 0700
Fax: +61 8 6217 0799