

INDUSTRY
KITCHENS

www.industrykitchens.com.au 1800 611 058

POLAR

Beer Dispenser

Instruction manual



Model:
GE632-A/GE633-A

Safety Instructions

Please take a few moments to carefully read through this manual. Correct maintenance and operation of this machine will provide the best possible performance from your POLAR product.

- Position on a flat, stable surface.
- A service agent/qualified technician should carry out installation and any repairs if required. Do not remove any components or service panels on this product.
 - **In Queensland the service agent/qualified technician MUST hold a Gas Work Authorisation or License for hydrocarbon refrigerants if the appliance gas system is being opened or charged.**
- Consult Local and National Standards to comply with the following:
 - Health and Safety at Work Legislation
 - Fire Precautions
 - Wiring Regulations
 - Building Regulations
- DO NOT use jet/pressure washers to clean the appliance.
- DO NOT use the appliance outside.
- DO NOT store food in the appliance.
- DO NOT use this appliance to store medical supplies.
- DO NOT allow oil or fat to come into contact with the plastic components or door seal. Clean immediately if contact occurs.
- DO NOT store products on top of the appliance.
- Always carry, store and handle the appliance in a vertical position and move by holding the base of the appliance.
- Always switch off and disconnect the power supply to the unit before cleaning.
- This appliance can be used by children aged from 8 years and above and persons with reduced physical, sensory or mental capabilities or lack of experience and knowledge if they have been given supervision or instruction concerning use of the appliance in a safe way and understand the hazards involved.

- Children shall not play with the appliance.
- Cleaning and user maintenance shall not be made by children without supervision.
- Keep the appliance and its cord out of reach of children less than 8 years.
- Keep all packaging away from children. Dispose of the packaging in accordance with the regulations of local authorities.
- The appliance is not intended to be operated by means of an external timer or separate remote-control system.
- Polar recommend that this appliance should be periodically tested (at least annually) by a Competent Person. Testing should include, but not be limited to: Visual Inspection, Polarity Test, Earth Continuity, Insulation Continuity and Functional Testing.

Caution: Risk of Fire 

- Do not store explosive substances such as aerosol cans with a flammable propellant in this appliance.



Warning: Keep all ventilation openings clear of obstruction. Unit should not be boxed in without adequate ventilation.

- **To comply with AS/NZS 60079.10.1:2009: Ensure there are not sources of ignition in any area where refrigerant could gather in the event of a leak.**
- **Electrical equipment should not be placed under the vent or where refrigerant could gather in the event of a leak.**
- **Warning:** Do not use mechanical devices or other means to accelerate the defrosting process, other than those recommended by the manufacturer.
- **Warning:** Do not damage the refrigerant circuit.
- **Warning:** Do not use electrical appliances inside the food storage compartments of the appliance.

Product Description

GE632-A - Direct Draw Beer Dispenser (1 Keg 1 Tap)

GE633-A - Direct Draw Beer Dispenser (2 Keg 2 Tap)

Pack Contents

The following is included:

- Beer Dispenser
- Drip pan
- Beer tower assembly
- CO₂ line
- Tee joint for CO₂ lines
- Screws and washers
- Multi-function spanner
- Instruction manual

POLAR prides itself on quality and service, ensuring that at the time of unpacking the contents are supplied fully functional and free of damage.

Should you find any damage as a result of transit, please contact your POLAR dealer immediately.

Installation

Note: Not for use in vans or trailers, food trucks or similar vehicles.

Note: If the unit has not been stored or moved in an upright position, let it stand upright for approximately 12 hours before operation. If in doubt allow to stand.

1. Remove the appliance from the packaging. Make sure that all protective plastic film and coatings are thoroughly removed from all surfaces.
2. To optimize performance and longevity, ensure a minimum clearance of 2.5cm is maintained between the unit and walls and other objects, with a minimum 20cm clearance on the top.
NEVER LOCATE NEXT TO A HEAT SOURCE.



Note: Before using the appliance for the first time, clean the interior with soapy water and dry well.

Location

- The appliance is intended for indoor use only.
- Be sure the location chosen has a floor strong enough to support the total weight of the cabinet and contents. A fully loaded unit can weigh as much as 450kg. Reinforce the floor as necessary to provide maximum loading.
- For the most efficient refrigeration, be sure to provide good air circulation inside and outside.

Ventilation

- Be sure that the unit has access to ample air. Avoid hot corners and locations near stoves and ovens.
- Should it become necessary to lay the unit on its side or back for any reason, allow at least 12 hours before start-up so as to allow compressor oil to flow back to the sump. Failure to meet this requirement can cause compressor failure and unit damage.

Levelling

- A level cabinet will perform better because the doors will line up with the frames properly, the cabinet will not be subject to undue strain and the contents inside the cabinet will not move around.
- Use a level to make sure the unit is level from front to back and side to side.
- Units supplied with legs will have adjustable bullet feet to make the necessary adjustments. If the unit is supplied with castors, set the brakes on the castors to keep the appliance in position.
- Ensure the floor where the unit is to be located is level.



Caution:
Failure to follow all the due installation instructions will invalidate your guarantee.

Connection

Connecting the beer tower

1. Pull out the air conduct hose from the hole in the cabinet surface.

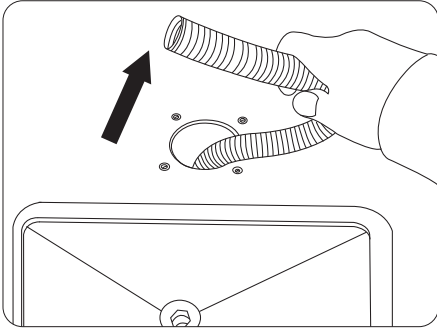

2. Unscrew the 2 bolts to release the cover plate which is located on the cabinet's inner surface.

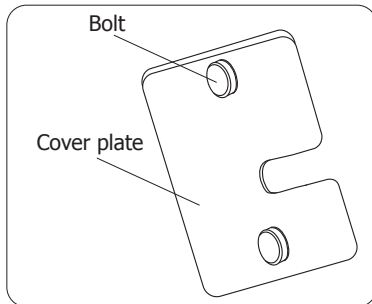

3. Thread the big black washer through the beer line that is coming from the beer tower.

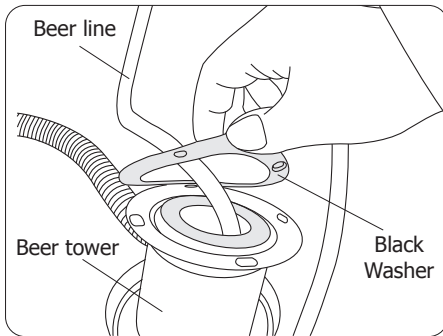

4. Insert the beer line into the cabinet via the hole. Then insert the air conduct hose into the beer tower.

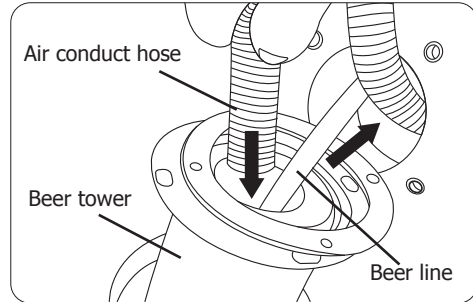

5. Align all holes and install the 4 screws to fix the beer tower in place.

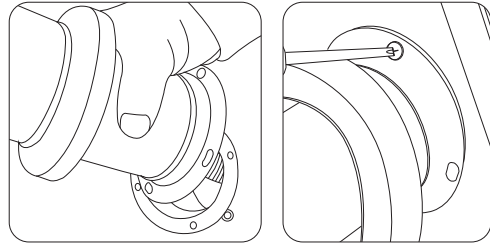

6. Slide the beer tower's shade downward fully.

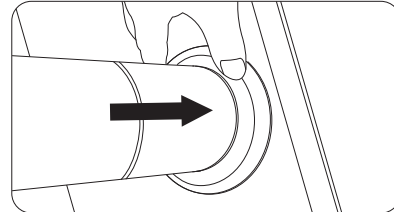

7. Re-attach and fix the cover plate to the cabinet's inner surface with bolts.

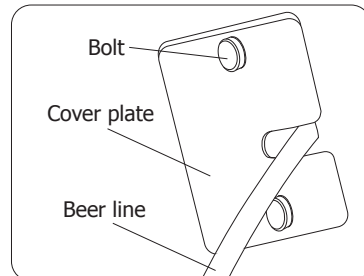

8. In case the beer tower is not stable, you can adjust the tap as needed. Open the top cap of the beer tower first. Then use the supplied spanner to adjust the tap.

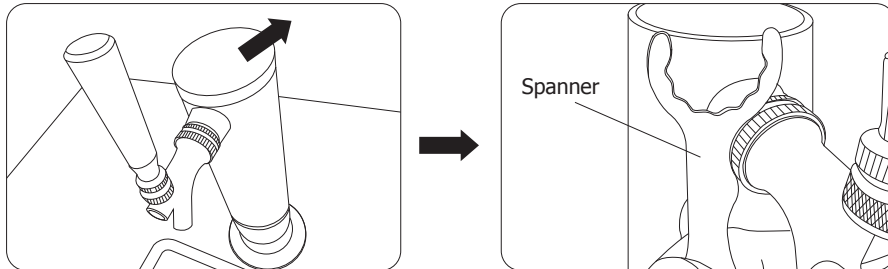

Connecting the CO₂ cylinder and beer keg



Note: The diagram below is for reference only. For actual connections, please follow the manufacturer's instructions supplied with the CO₂ cylinder and beer keg. All connections should be done by professionals only.

Be gentle when locating CO₂ cylinder and beer keg into the cabinet to avoid any damage.

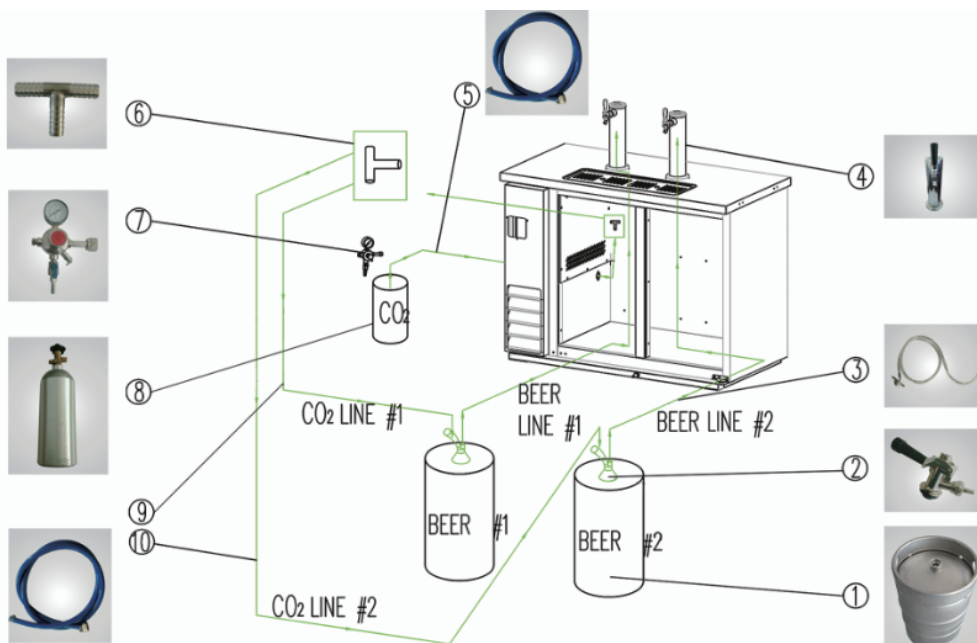

- | | |
|----------------------------|---|
| 1. Beer keg (Not supplied) | 6. Tee Joint for CO ₂ lines |
| 2. Keg tap | 7. CO ₂ regulator (Not supplied) |
| 3. Beer line | 8. CO ₂ cylinder (Not supplied) |
| 4. Beer tower | 9. CO ₂ line (#1) |
| 5. CO ₂ line | 10. CO ₂ line (#2) |



Warning:

- Make sure that all fittings in system are tight. Always keep the CO₂ cylinder in vertical position. The recommended pressure for the CO₂ system is 8-10 psi.
- Always handle the CO₂ cylinder with care. Never lay flat or drop!
- Handle all pressure system components with care. Do not use excessive pressures. Be sure instructions are understood thoroughly. If in doubt, contact your dealer/distributor for explanation.
- Filled CO₂ cylinders are potentially dangerous because of the pressure they contain. If you are unfamiliar with their use or the use of the CO₂ regulator, seek information from your local distributor, or your local beverage man before proceeding.



When necessary to connect a remote CO₂ cylinder, use below diagram for reference. For actual connections, ensure to follow the manufacturer's instructions supplied with the CO₂ cylinder.

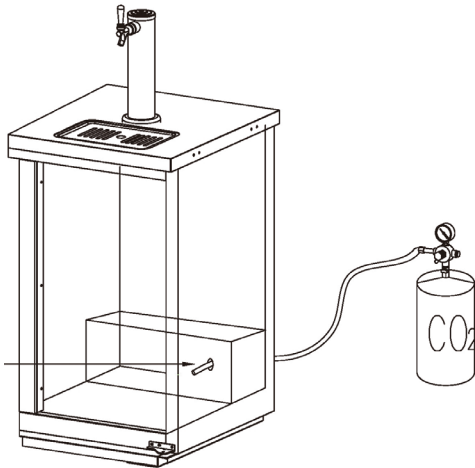

Beer keg layout: Model GE632-A

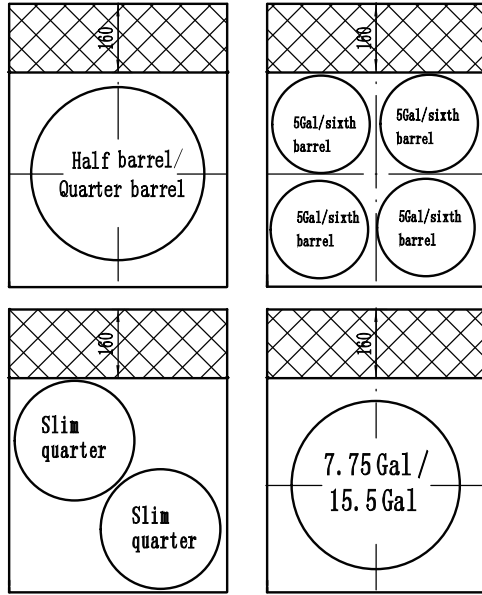

Beer keg layout: Model GE633-A

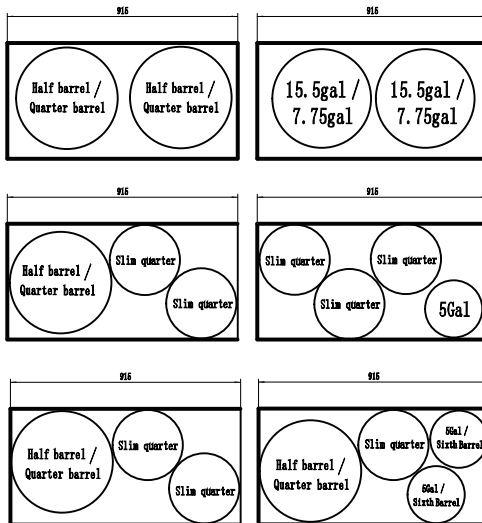

Beer keg layout: Model GE633-A

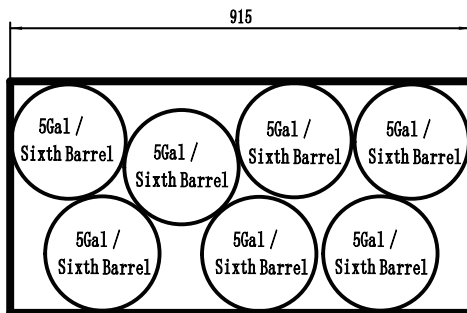
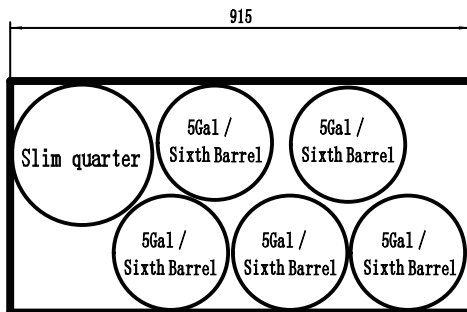
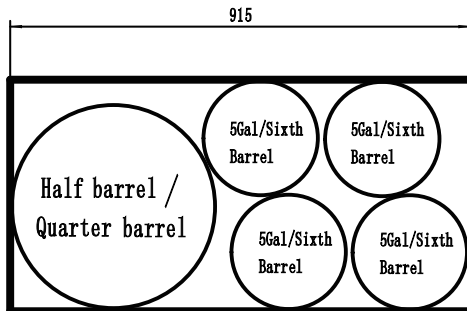

Operation

Control Panel

For GE632-A: The control panel is located on the rear wall inside the cabinet.

For GE633-A: The control panel is located on the front of the appliance.

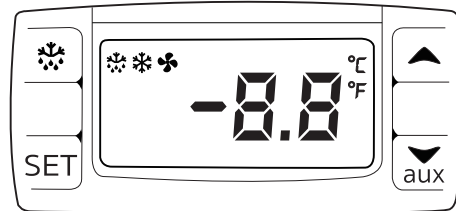

To lock/unlock the keyboard, press ▲ and ▼ together for more than 3 seconds. Display will flash POF (locked) / PON (unlocked).

Turn On

1. Close the door(s) of the appliance.
2. Connect the appliance to a mains power supply.

Set the Operating Temperature

1. Hold the **SET** button for 3 seconds. The value of the current set point will be displayed.
2. Press the ▲ or ▼ button to display the required temperature.
3. Press the **SET** button to store the temperature.

Manual Defrost

Press and hold the defrost button ❄️ for 2 seconds to begin a manual defrost. The defrost light illuminates.

The defrost cycle will end automatically.

Lock/Unlock the Doors

Use the keys provided to lock/unlock the door.

Serving

- Before serving, ensure to locate the drip tray(s) in place.

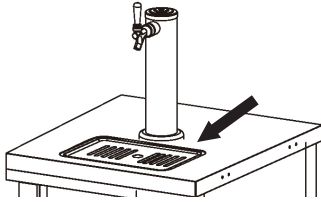

- Pull the tap toward you to begin pouring.
- Raise the tap handle to close the tap.

Cleaning, Care & Maintenance

Switch off and disconnect from the power supply before cleaning and maintenance.

- Warm, soapy water is recommended for cleaning. Cleaning agents may leave harmful residues. Wipe the exterior with a damp cloth.
- Empty and clean the drip trays regularly.



Note: Condensation will form in refrigeration on hot humid days, please ensure condensation is allowed to drain properly or is wiped dry.

Cleaning the cabinet

The interior and exterior can be cleaned using soap and warm water. If this is not sufficient, try ammonia and water or a non-abrasive liquid cleaner. When cleaning the exterior, always rub with the "grain" of the stainless steel to avoid marring the finish.

Do not use an abrasive cleaner because it will scratch the stainless steel and plastic and can damage the breaker strips and gaskets.

Cleaning the Condenser Coil

The condenser coil requires regular cleaning, with the recommended frequency of every 90 days. In some instances, you may find there is a large amount of debris and dust or grease accumulated prior to the 90-day period. Thus the condenser coil should be cleaned more frequently.

If the buildup on the coil consists of only light dust and debris the condenser coil can be cleaned with a simple brush. Heavier dust buildup may require a vacuum or even compressed air to blow through the condenser coil.

If heavy grease is present, there are de-greasing agents available for refrigeration use and specifically for the condenser coils. The condenser coil may require a spray with the de-greasing agent and then blown through with compressed air.

Failure to maintain a clean condenser coil can initially cause high temperatures and excessive run times, continuous operation with dirty or clogged condenser coils can result in compressor failures. Neglecting the condenser coil cleaning procedures will void any warranties associated with the compressor or cost to replace the compressor.

In order to maintain proper refrigeration performance, the condenser fins must be cleaned of dust, dirt and grease regularly. It is recommended that this be done at least every 3 months. If conditions are such that the condenser is totally blocked, the frequency of cleaning should be increased. Clean the condenser with a vacuum cleaner or stiff brush. If extremely dirty, a commercially available condenser cleaner may be required.

Stainless Steel Care

To maintain the stainless steel exterior of your Polar item, please consider the following information:

Never:

- Use abrasive Scourers or scrubbing pads, etc.
- Use Chlorinated or acidic detergents
- Allow anything e.g. food, dirt, cleaning chemicals to remain on the surface for longer than necessary, clean them off right away.
- Allow the surface to remain wet.

Do:

- Clean often.
- Use soft Cloths or plastic Scourers.
- Rub with the grain of the metal, rather than across it.
- Use detergents and polish designed for cleaning Stainless Steel.
- Ensure that the cleaning products are washed off fully and that the steel is left dry.

Gasket Maintenance

Gaskets require regular cleaning to prevent mould and mildew buildup and also to keep the elasticity of the gasket.

Gasket cleaning can be done with the use of warm soapy water. Avoid full strength cleaning products on gaskets as this can cause them to become brittle and prevent proper seals. Also, never use sharp tools or knives to scrape or clean the gasket which could possibly tear the gasket and rip the bellows.

Gaskets can easily be replaced and do not require the use of tools or authorized service persons. The gaskets are "Dart" style and can be pulled out of the grove in the door and new gaskets can be "pressed" back into place.

Doors/Hinges

Over time and with heavy use, doors the hinges may become loose. If it is noticed that the door is beginning to sag, it may become necessary to tighten the screws that mount the hinge brackets to the frame of the unit. If the doors are loose or sagging this can cause the hinge to pull out of the frame which may damage both the doors and the door hinges. In some cases this can require qualified service agents or maintenance personnel.

Drain Maintenance

Each unit has a drain located inside the unit which removes the condensation from the evaporator coil and evaporates it at an external condensate evaporator pan. The drain may become loose or even disconnected resulting from moving or bumping the drain.

If you notice excessive water accumulation on the inside of the unit, be sure the drain tube is connected from the evaporator housing to the condensate evaporator drain pan.

If water is collected underneath the unit, you may need to check the condensate evaporator drain tube to make sure it is still located inside the drain pan.

The levelling of the unit is important as the units are designed to drain properly when on a level surface. If your floor is not level this can also cause drain problems. Make sure all drain lines are free of obstructions, or blocked drain lines will cause water to back up and overflow the drain pans.

Troubleshooting

A qualified technician must carry out repairs if required.

Fault	Probable Cause	Solution
The appliance is not working	The unit is not switched on	Check the unit is plugged in correctly and switched on
	Plug or lead is damaged	Replace plug or lead
	Mains power supply fault	Check mains power supply
Cabinet temperature is too Warm	Doors are not shut properly	Check doors are shut and seals are not damaged
	Appliance is located near a heat source or air flow to the condenser is being interrupted	Move the appliance to a more suitable location
	Ambient temperature is too high	Increase ventilation or move appliance to a cooler position
	Insufficient airflow to the fans	Remove any blockages to the fans
	The set temperature is too high	Set a lower temperature
	Low refrigerant level	Consult a qualified Technician
Condensation on the Cabinet and/or floor	Gasket not sealing well	Clean, repair, or replace the gasket as necessary

Technical Specifications

Note: Due to our continuing program of research and development, the specifications herein may be subject to change without notice.

Model	Voltage	Power	Current	Temperature Range	Refrigerant	Dimensions H x W x D mm	Weight (kg)
GE632-A	220-240V~ 50Hz	150W	1.1A	2°C ~ 8°C	R600a (55g)	1312 x 612 x 810	63
GE633-A		250W	1.6A	2°C ~ 8°C	R290 (95g)	1438 x 1247 x 620	97

Electrical Wiring

The plug is to be connected to a suitable mains socket.

This appliance is wired as follows:

- Live wire (coloured brown) to terminal marked L
- Neutral wire (coloured blue) to terminal marked N
- Earth wire (coloured green/yellow) to terminal marked E

The appliances must be earthed.



If in doubt consult a qualified electrician.

Electrical isolation points must be kept clear of any obstructions. In the event of any emergency disconnection being required they must be readily accessible.

Compliance

The product must not be disposed of as household waste. To help prevent possible harm to human health and/or the environment, the product must be disposed of in an approved and environmentally safe recycling process. For further information on how to dispose of this product correctly, contact the product supplier, or the local authority responsible for waste disposal in your area.

POLAR parts have undergone strict product testing in order to comply with regulatory standards and specifications set by international, independent, and federal authorities.

POLAR products have been approved to carry the following symbol:



All rights reserved. No part of these instructions may be produced or transmitted in any form or by any means, electronic, mechanical, photocopying, recording or otherwise, without the prior written permission of POLAR. Every effort is made to ensure all details are correct at the time of going to press, however, POLAR reserve the right to change specifications without notice.

DECLARATION OF CONFORMITY

• Conformiteitsverklaring • Déclaration de conformité • Konformitätserklärung • Dichiarazione di conformità • Declaración de conformidad

Equipment Type • Uitrustingstype • Type d'équipement • Gerätetyp • Tipo di apparecchiatura • Tipo de equipo	Model • Modèle • Modell • Modello • Modelo
G-series Direct Draw Keg Beer Dispenser Single G-series Direct Draw Keg Beer Dispenser Double	GE632 (E&-A) GE633 (E&-A)
Application of Territory Legislation & Council Directives(s) Toepassing van Europese Richtlijn(en) • Application de la/des directive(s) du Conseil • Anwendbare EU-Richtlinie(n) • Applicazione delle Direttive • Aplicación de la(s) directiva(s) del consejo	<p>Machinery Directive 2006/42/EC Supply of Machinery (Safety) Regulations 2008 (BS) EN 60335-1:2012 +A11:2014 +A13:2017 +A1:2019 +A14:2019 +A2:2019 (BS) EN 60335-2-89:2010 +A1:2016 +A2:2017 (BS) EN 62233:2008</p> <p>Electro-Magnetic Compatibility (EMC) Directive 2014/30/EU - recast of 2004/108/EC Electromagnetic Compatibility Regulations 2016 (S.I. 2016/1091) (BS) EN IEC 55014-1:2021 (BS) EN IEC 55014-2:2021 (BS) EN IEC 61000-3-2: 2019 +A1:2021 (BS) EN 61000-3-3: 2013 +A1:2019 +A2:2021</p> <p>Eco-design energy-related products Directive 2009/125/EC; Regulation (EU) 2015/1095 - Ecodesign professional refrigerators (BS) EN 16825: 2016</p> <p>Restriction of Hazardous Substances Directive (RoHS) 2015/863 amending Annex II to Directive 2011/65/EU Restriction of the Use of Certain Hazardous Substances in Electrical and Electronic Equipment Regulations 2012 (S.I. 2012/3032)</p>
Producer Name • Naam fabrikant • Nom du producteur • Name des Herstellers • Nome del produttore • Nombre del fabricante	Polar

I, the undersigned, hereby declare that the equipment specified above conforms to the above Territory Legislation, Directive(s) and Standard(s).

Ik, de ondergetekende, verklaar hierbij dat de hierboven gespecificeerde uitrusting goedgekeurd is volgens de bovenstaande Richtlijn(en) en Standaard(en).

Je soussigné, confirme la conformité de l'équipement cité dans la présente à la / aux Directive(s) et Norme(s) ci-dessus

Ich, der/die Unterzeichnende, erkläre hiermit, dass das oben angegebene Gerät der/den oben angeführten Richtlinie(n) und Norm(en) entspricht.

Il sottoscritto dichiara che l'apparecchiatura di sopra specificata è conforme alle Direttive e agli Standard sopra riportati.

El abajo firmante declara por la presente que el equipo arriba especificado está en conformidad con la(s) directiva(s) y estándar(es) arriba mencionadas.

Date • Data • Date • Datum • Data • Fecha

Signature • Handtekening • Signature • Unterschrift Firma • Firma

Full Name • Volledige naam • Nom et prénom • Vollständiger Name • Nome completo • Nombre completo

Position • Functie • Fonction • Position • Qualifica • Posición

Producer Address • Adres fabrikant • Adresse du producteur • Anschrift des Herstellers • Indirizzo del produttore • Dirección del fabricante

19 th May 2023		
DocuSigned by: <i>Ashley Hooper</i> B39382C9FD9C478...	DocuSigned by: <i>Eoghan Donnellan</i> D352874F7FAB460...	DocuSigned by: <i>Brendan Denmeade</i> D052C5837EB7465...
Ashley Hooper	Eoghan Donnellan	Brendan Denmeade
Technical & Quality Manager	Commercial Manager/Importer	Commercial Manager/Responsible Supplier
Fourth Way, Avonmouth, Bristol, BS11 8TB United Kingdom	Unit 9003, Blarney Business Park, Blarney, Co. Cork Ireland	15 Bagdally Road, Campbelltown NSW 2560



POLAR



Please see website for the latest version of the manual

<http://www.polar-refrigerator.com/> 

GE632-A_GE633-A_A5_v2_2023/06/20