

# SOLSTICE SUPREME GAS FRYERS

SSH75, SSH75C

INDUSTRY  
KITCHENS  
www.industrykitchens.com.au 1800 611 058



Pitco SSH55 and SSH75C fryers with Solstice Supreme Burner Technology offer energy-saving, high-production frying. They deliver up to 70% thermal efficiency and ENERGYSTAR® performance without the need for complex blowers. The self-cleaning burner runs a 30-second daily cycle for optimal efficiency. Patented Down Draft Protection optimises combustion efficiency, making these fryers low-maintenance and reliable – ideal for high-volume restaurants and multi-store chains.

## STANDARD FRYER FEATURES & ACCESSORIES

- Tank - stainless steel construction
- Cabinet - stainless front, door and sides
- Solstice Burner Technology, No blower or ceramics
- High Efficiency design, EnergyStar performance
- Patented Self Cleaning Burner & Down Draft Protection
- Solid State T-Stat with melt cycle & boil out mode
- Matchless Ignition automatically lights the pilot when the power is turned on
- DVI drain valve interlock safety system turns the heat off preventing the oil from scorching / overheating.
- High Temperature safety limit switch
- Heavy duty 3/16" bottom door hinge
- 1 ¼" (32 mm) Full port drain valve for fast draining
- Separate Manual gas shutoffs, for front servicing
- Integrated flue deflector
- 9" (229 mm) adjustable legs, easier access to clean
- Tube rack, allows crumbs & debris into cool zone
- Removable basket hanger, requires no tools
- Drain Line Clean out rod
- Drain Extension
- Fryer cleaner sample packet
- 3 Baskets

## CONTROL OPTIONS

### Solid State Control – SSH75

Temperature Monitoring  
Auto Lighting of Pilot  
Melt Cycle  
Boil Out



### 12-Button Computer Control – SSH75C

Turning On/Off  
Temperature Monitoring  
Auto Lighting of Pilot  
Cooking Timer  
Shake & Hold Timers  
Load Compensation Mode  
Boil Out Mode  
Melt Cycle  
Programming Mode  
Adjustable Alarm & Alerts  
Dual Vat Control  
Password Option



Solid State Control option shown

Note: The controller style must be specified when ordering. Standard fryers come with one type only.

Please note, due to ongoing product development and improvement, we reserve the right to change product design and specification at any time without notice.



**HEAD OFFICE  
AND MANUFACTURING PLANT**  
211-217 Woodpark Road  
Smithfield NSW 2164

**VIC – TAS**  
47 Stubbs Street,  
Kensington  
VIC 3031

**QLD**  
U12, 210 Queensport  
Rd Nth, Murarrie  
QLD 4172

**WA**  
U2, 9 Meares Way,  
Canning Vale WA  
6155

**1800 013 123  
+61 2 9604 7333  
sales@middleby.com.au  
middleby.com.au**

# SOLSTICE SUPREME GAS FRYERS

SSH75, SSH75C



## SPECIFICATIONS

Dimensions (W x D x H)	498 x 875 x 1172mm
Cooking Area (W x D x H)	457 x 127 x 457mm
Oil Capacity	+/-36 Litres
Rating	116MJ
Weight	125Kg

## INSTALLATION CLEARANCES

Front min.	762mm
Floor min.	153mm
Combustible material - Sides min.	152mm
Combustible material - Rear min.	152mm
Non-Combustible material - Sides min.	0
Non-Combustible material - Rear min.	0
Fryer Flue Area	Do not block / restrict flue gases from flowing into hood or install vent hood drains over the flue.

## GAS SYSTEM REQUIREMENTS

	NG	LPG
Store Supply Pressure*	17.4 mbars/ 1.7 kPa	27.4 mbars/ 2.7 kPa
Burner Manifold Pressure	10 mbars / 1 kPa	25mbars/ 2.4 kPa

Minimum 10amp 240V supply, Plug not included.

\* Check plumbing / gas codes for proper gas supply line sizing to sustain burner pressure when all gas appliances are full on.

- A** Electrical Connection
- B** 3/4" BSP Gas Connection
- C** Solid State Controls
- D** Computer Control Panel
- E** Basket Lifter (Optional)

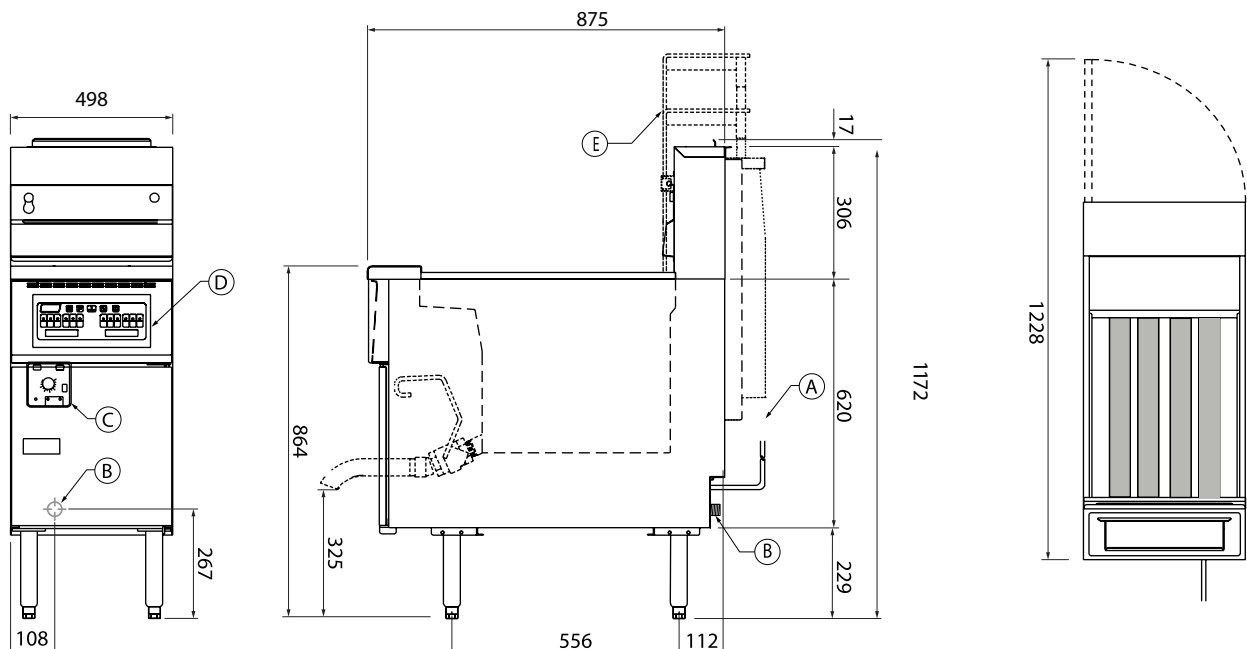

Please note, due to ongoing product development and improvement, we reserve the right to change product design and specification at any time without notice.



**HEAD OFFICE  
AND MANUFACTURING PLANT**  
211-217 Woodpark Road  
Smithfield NSW 2164

**VIC - TAS**  
47 Stubbs Street,  
Kensington  
VIC 3031

**QLD**  
U12, 210 Queensport  
Rd Nth, Murarrie  
QLD 4172

**WA**  
U2, 9 Meares Way,  
Canning Vale WA  
6155

**1800 013 123**  
**+61 2 9604 7333**  
**sales@middleby.com.au**  
**middleby.com.au**