

SOLSTICE SUPREME GAS FRYERS

INDUSTRY
KITCHENS

www.industrykitchens.com.au 1800 611 058



SSH75-FD, SSH75C-FD

Pitco SFSSH75-FD and SSH75C-FD fryers combine space-saving filtering with energy-efficient, high-production frying. Solstice Supreme Burner Technology delivers up to 70% thermal efficiency and ENERGYSTAR® performance without complex blowers. The self-cleaning burner runs a 30-second daily cycle for optimal efficiency, while Patented Down Draft Protection optimises combustion efficiency. A simple two-step filtering system keeps oil clean for fresher products and longer oil life.

STANDARD FRYER FEATURES & ACCESSORIES

- Tank - stainless steel construction
- Cabinet - stainless front, door and sides
- Patented Solstice Burner Technology, No blower or ceramics
- Patented Self Cleaning Burner & Down Draft Protection
- High Efficiency design, EnergyStar performance
- Solid State T-Stat with melt cycle and boil out mode
- Matchless Ignition with DVI drain valve interlock
- High Temperature safety limit switch
- Heavy duty 3/16" bottom door hinge
- 1 ¼" (32 mm) Full port drain valve for fast draining
- Separate Manual gas shutoffs, for front servicing
- Integrated flue deflector
- 10" (254mm) adjustable front legs and rear rigid castors, easier access to clean
- Tube rack, allows crumbs & debris into cool zone
- Removable basket hanger, requires no tools
- Drain Line Clean out rod
- Fryer cleaner sample packet
- 3 Baskets

STANDARD FILTER FEATURES & ACCESSORIES

- Simple two-step filtration
- Fast filtering with a 30L per minute pump for quick oil refills
- Easy, hassle-free hookup with a self-aligning filter connection
- Rear oil return helps clean the fryer bottom
- Durable stainless steel filter pan with rear wheels for easy movement
- Convenient self-storing lid stays out of the way
- Comes standard with: washdown/discharge hose, 50 envelope filter papers, starter pack of filter powder, lids, and brush

CONTROL OPTIONS

Solid State Control – SSH75-FD

Temperature Monitoring
Auto Lighting of Pilot
Melt Cycle
Boil Out



12-Button Computer Control – SSH75C-FD

Turning On/Off
Temperature Monitoring
Auto Lighting of Pilot
Cooking Timer
Shake & Hold Timers
Load Compensation Mode
Boil Out Mode
Melt Cycle
Programming Mode
Adjustable Alarm & Alerts
Dual Vat Control
Password Option



Solid State Control option shown

Note: The controller style must be specified when ordering. Standard fryers come with one type only.

Please note, due to ongoing product development and improvement, we reserve the right to change product design and specification at any time without notice.



**HEAD OFFICE
AND MANUFACTURING PLANT**
211-217 Woodpark Road
Smithfield NSW 2164

VIC – TAS
47 Stubbs Street,
Kensington
VIC 3031

QLD
U12, 210 Queensport
Rd Nth, Murarrie
QLD 4172

WA
U2, 9 Meares Way,
Canning Vale WA
6155

**1800 013 123
+61 2 9604 7333
sales@middleby.com.au
middleby.com.au**

SOLSTICE SUPREME GAS FRYERS

SSH75-FD, SSH75C-FD



SPECIFICATIONS

Dimensions (W x D x H)	498 x 875 x 1197mm
Cooking Area (W x D x H)	457 x 127 x 457mm
Oil Capacity	+/-36 Litres
Rating	116MJ
Weight	158Kg

INSTALLATION CLEARANCES

Front min.	762mm
Floor min.	153mm
Combustible material - Sides min.	152mm
Combustible material - Rear min.	152mm
Non-Combustible material - Sides min.	0
Non-Combustible material - Rear min.	0
Fryer Flue Area	Do not block / restrict flue gases from flowing into hood or install vent hood drains over the flue.

- A** Electrical Connection
- B** 3/4" BSP Gas Connection
- C** Solid State Controls
- D** Computer Control Panel
- E** Basket Lifter (Optional)

GAS SYSTEM REQUIREMENTS

	NG	LPG
Store Supply Pressure*	17.4 mbars/ 1.7 kPa	27.4 mbars/ 2.7 kPa
Burner Manifold Pressure	10 mbars / 1 kPa	25mbars/ 2.4 kPa

FILTER SPECIFICATIONS

Voltage/Frequency/Amps	240/50/3.5
Filter pump rated flow	30LPM

Minimum 10amp 240V supply, Plug not included.

* Check plumbing / gas codes for proper gas supply line sizing to sustain burner pressure when all gas appliances are full on.

Note: If solid oil/lard is being used in filtration fryers, then it is required as per manufacturer's specifications, to have heat tape fitted ex-factory. Warranty will be void if the unit is not being used as per the manufacturer's recommendations.

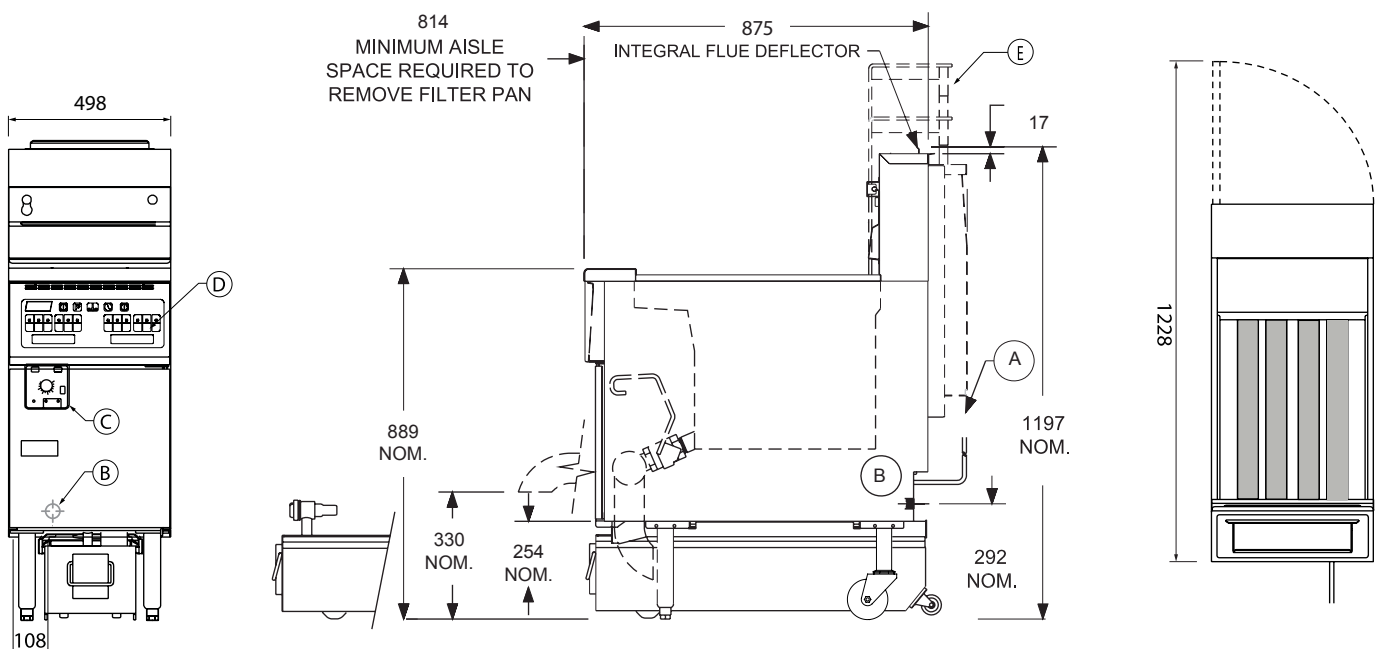

Please note, due to ongoing product development and improvement, we reserve the right to change product design and specification at any time without notice.



**HEAD OFFICE
AND MANUFACTURING PLANT**
211-217 Woodpark Road
Smithfield NSW 2164

VIC - TAS
47 Stubbs Street,
Kensington
VIC 3031

QLD
U12, 210 Queensport
Rd Nth, Murarrie
QLD 4172

WA
U2, 9 Meares Way,
Canning Vale WA
6155

1800 013 123
+61 2 9604 7333
sales@middleby.com.au
middleby.com.au