

SOLSTICE SUPREME GAS FRYERS

SSH55-3/FD, SSH55C-3/FD

INDUSTRY
KITCHENS

www.industrykitchens.com.au 1800 611 058



The Pitco solstice supreme gas fryer offers high product output and outstanding quality with every single cook. Designed for high volume usage, this commercial fryer features a +/-23 litre oil capacity per tank, and an efficient output of 88 MJ per hour per tank. They fry as much food as +110MJ fryers while using less than 90MJ. This solstice energy efficient tube fired fryer ensures fast recovery times and less oil absorption, resulting in better quality fried food with a crispy finish. The built in oil filtration further increases the lifespan of the oil, resulting in huge savings on oil.

STANDARD FRYER FEATURES & ACCESSORIES

- Tank - stainless steel construction
- Cabinet - stainless front, door and sides
- Solstice Burner Technology, No blower or ceramics
- High Efficiency design, EnergyStar performance
- Patented Self Cleaning Burner & Down Draft Protection
- Solid State T-Stat with melt cycle & boil out mode
- Matchless Ignition automatically lights the pilot when the power is turned on
- DVI drain valve interlock safety system turns the heat off preventing the oil from scorching / overheating.
- High Temperature safety limit switch
- Heavy duty 3/16" bottom door hinge
- 1 1/4" (32 mm) Full port drain valve for fast draining
- Separate Manual gas shutoffs, for front servicing
- Integrated flue deflector
- 9" swivel castors with front brakes easier access to clean
- Tube rack, allows crumbs & debris into cool zone
- Removable basket hanger, requires no tools
- Drain Line Clean out rod
- Drain Extension
- Fryer cleaner sample packet
- 2 Baskets per tank

CONTROL OPTIONS

Solid State Control – SSH55

Temperature Monitoring
Auto Lighting of Pilot
Melt Cycle
Boil Out



12-Button Computer Control – SSH55C

Turning On/Off
Temperature Monitoring
Auto Lighting of Pilot
Cooking Timer
Shake & Hold Timers
Load Compensation Mode
Boil Out Mode
Melt Cycle
Programming Mode
Adjustable Alarm & Alerts
Dual Vat Control
Password Option



THREE FRYER FILTER SYSTEM

- Simple two-step filtration
- Fast filtering with a 30L per minute pump for quick oil refills
- Easy, hassle-free hookup with a self-aligning filter connection
- Rear oil return helps clean the fryer bottom
- Durable stainless steel filter pan with rear wheels for easy movement
- Convenient self-storing lid stays out of the way
- Comes standard with: washdown/discharge hose, 50 envelope filter papers, starter pack of filter powder, lids, and brush



Solid State Control option shown

Note: The controller style must be specified when ordering. Standard fryers come with one type only.

Please note, due to ongoing product development and improvement, we reserve the right to change product design and specification at any time without notice.



**HEAD OFFICE
AND MANUFACTURING PLANT**
211-217 Woodpark Road
Smithfield NSW 2164

VIC – TAS
47 Stubbs Street,
Kensington
VIC 3031

QLD
U12, 210 Queensport
Rd Nth, Murarrie
QLD 4172

WA
U2, 9 Meares Way,
Canning Vale WA
6155

**1800 013 123
+61 2 9604 7333
sales@middleby.com.au
middleby.com.au**

SOLSTICE SUPREME GAS FRYERS

SSH55-3/FD, SSH55C-3/FD



SPECIFICATIONS

Dimensions (W x D x H)	1191 x 875 x 1172mm
Cooking Area (W x D x H) per tank	356 x 127 x 356mm
Oil Capacity per tank	+/-23 Litres
Rating	264MJ
Weight	406Kg

GAS SYSTEM REQUIREMENTS

	NG	LPG
Store Supply Pressure*	17.4 mbars/ 1.7 kPa	27.4 mbars/ 2.7 kPa
Burner Manifold Pressure	10 mbars / 1 kPa	25mbars/ 2.4 kPa

INSTALLATION CLEARANCES

Front min.	762mm
Floor min.	153mm
Combustible material - Sides min.	152mm
Combustible material - Rear min.	152mm
Non-Combustible material - Sides min.	0
Non-Combustible material - Rear min.	0
Fryer Flue Area	Do not block / restrict flue gases from flowing into hood or install vent hood drains over the flue.

FILTER SPECIFICATIONS

Voltage/Frequency/Amps	240/50/3.5
Filter pump rated flow	30LPM

Minimum 10amp 240V supply, Three plugs required (not included).

* Check plumbing / gas codes for proper gas supply line sizing to sustain burner pressure when all gas appliances are full on.

- A** Electrical Connection
- B** 3/4" BSP Gas Connection
- C** Solid State Controls
- D** Computer Control Panel
- E** Basket Lifter (Optional)

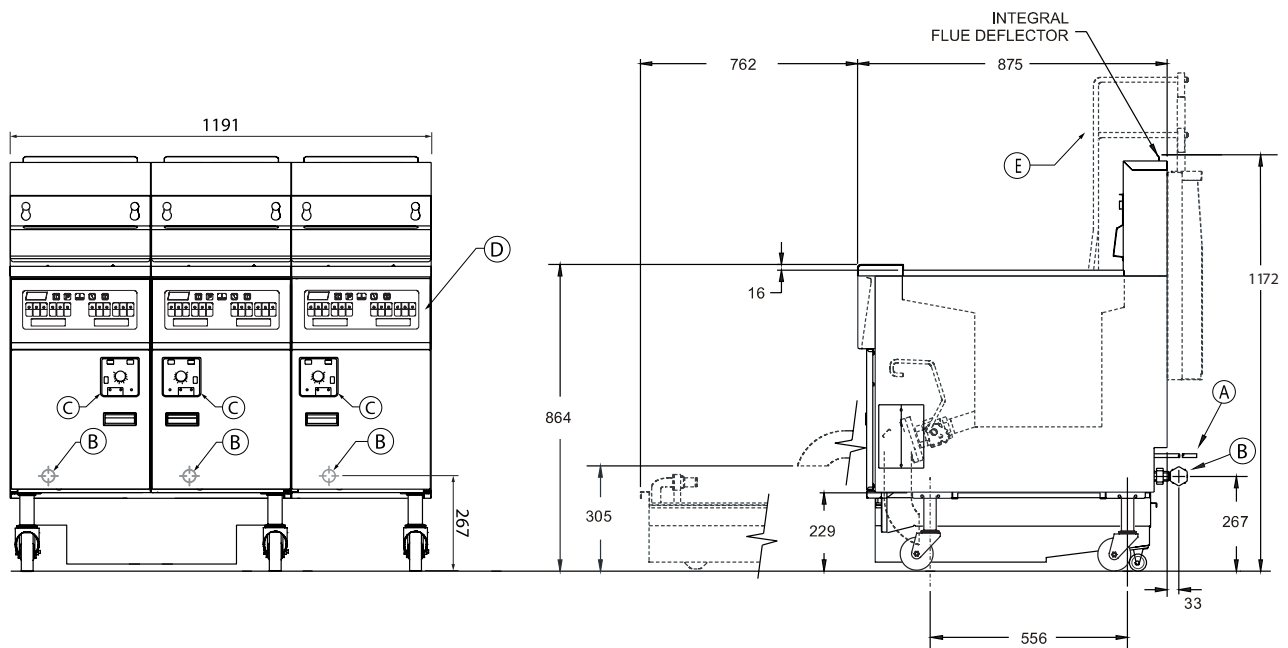
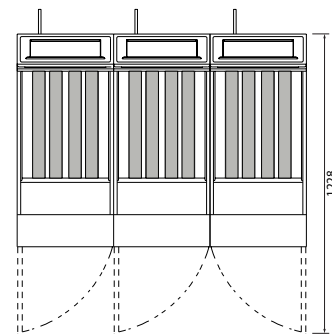

Please note, due to ongoing product development and improvement, we reserve the right to change product design and specification at any time without notice.



**HEAD OFFICE
AND MANUFACTURING PLANT**
211-217 Woodpark Road
Smithfield NSW 2164

VIC - TAS
47 Stubbs Street,
Kensington
VIC 3031

QLD
U12, 210 Queensport
Rd Nth, Murarrie
QLD 4172

WA
U2, 9 Meares Way,
Canning Vale WA
6155

1800 013 123
+61 2 9604 7333
sales@middleby.com.au
middleby.com.au