

**RP1RG, RP2R**  
**Retarder Prover**

**Product Features**

- Full stainless steel construction internal and external
- Easy to use electronic panel
- Fitted with insulated floor as standard
- Accommodates racks at 750mm x 525mm
- Humidity adjustable up to 100%
- Temperature adjustable up to 40°C
- Refrigeration adjustable down to -2°C
- Cabinet supplied complete
- RP1RG: Single swing door with fixed glass panel
- RP2R: Solid 2 swing doors

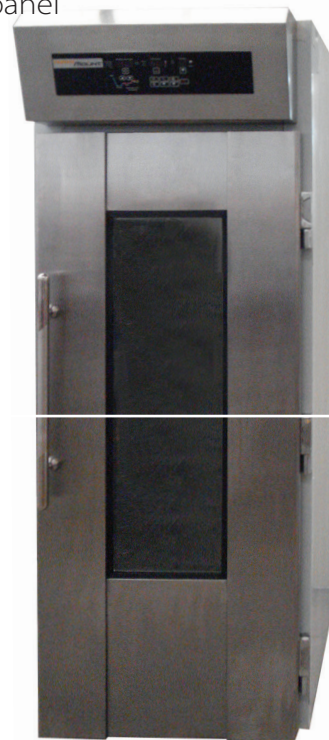

**RP1RG**

Sourced from the leading equipment manufacturers globally, the Paramount brand is renowned for quality equipment at an affordable price point. With a range including spiral dough mixers, hydraulic dividers, bun divider rounders, provers, deck and rotating ovens, bread slicers, planetary mixers and dough sheeters, Paramount offers solutions to your production requirements. Designed to withstand the demands of the modern bakery environment, the Paramount brand offers many years of trouble free operation.

A critical component in the quality of baked finish goods, our quality range of provers and retarder provers provide controlled climates with adjustable temperature and humidity settings.

## RP1RG, RP2R Retarder Prover

### Model RP1RG

Capacity	1 rack
<b>Dimensions</b>	
Width	780mm
Depth	1150mm
Height	2310mm
<b>Electrical Requirements</b>	
220-240V, 1P+N+E, 50Hz, 15amp	
Nett Weight	120kg

### Model RP2R

Capacity	2 rack
<b>Dimensions</b>	
Width	1860mm
Depth	1200mm
Height	2390mm
<b>Electrical Requirements</b>	
400-415V, 3P+N+E, 50Hz, 20amp	
Nett Weight	170kg

### Additional Information

Dimensions EXCLUDE all protrusions - door handles, drain exits etc...

Minimum ceiling height required: 2600mm

Refrigeration requires assembly, connection and gassing

### Units require the following:

- Drain Outlet
- ½" BSP Inlet

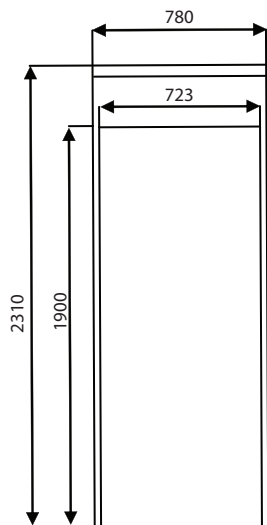

RP1RG

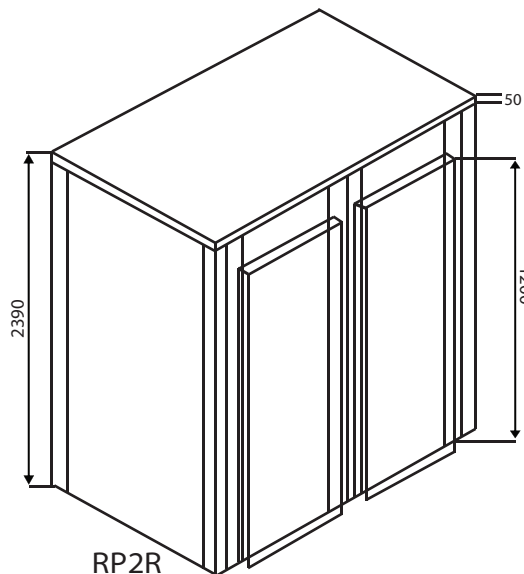

RP2R

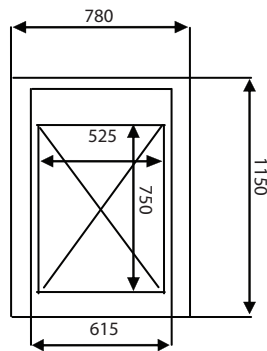

Door opening direction

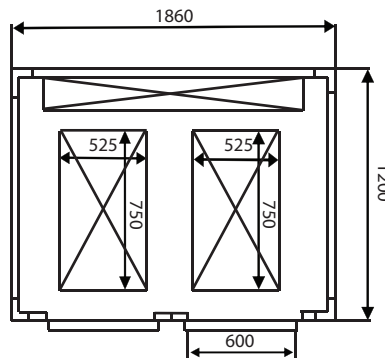

moffat.com.au  
moffat.co.nz

Australia  
moffat.com.au

Moffat Pty Limited

Victoria/Tasmania  
740 Springvale Road  
Mulgrave, Victoria 3170  
Telephone +613-9518 3888  
Facsimile +613-9518 3833  
vsales@moffat.com.au

New South Wales

Telephone +612-8833 4111  
nswsales@moffat.com.au

South Australia

Telephone +613-9518 3888  
vsales@moffat.com.au

Queensland

Telephone +617-3630 8600  
qldsales@moffat.com.au

Western Australia

Telephone +618-9413 2400  
wasales@moffat.com.au

New Zealand

moffat.co.nz

Moffat Limited

Rolleston

45 Illinois Drive  
Izone Business Hub  
Rolleston 7675  
Telephone +64 3-983 6600  
Facsimile +64 3-983 6600  
sales@moffat.co.nz

Auckland

Telephone +64 9-574 3150  
sales@moffat.co.nz



In line with policy to continually develop and improve its products, Moffat Limited reserves the right to change specifications and design without notice.

© Copyright Moffat Ltd  
AN.P.01.21

an Ali Group Company



The Spirit of Excellence