

P1R 16 Tray - Single Rack Prover

P2R 32 Tray - 2 Rack Prover

Product Features

- Full stainless steel construction internal and external
- Swing door fitted as standard
- Easy to use electronic panel
- Fitted with floor as standard
- Accommodates 750mm x 525mm racks
- Humidity adjustable up to 100%
- Temperature adjustable up to 40°C



P1R

Sourced from the leading equipment manufacturers globally, the Paramount brand is renowned for quality equipment at an affordable price point. With a range including spiral dough mixers, hydraulic dividers, bun divider rounders, provers, deck and rotating ovens, bread slicers, planetary mixers and dough sheeters, Paramount offers solutions to your production requirements. Designed to withstand the demands of the modern bakery environment, the Paramount brand offers many years of trouble free operation.

A critical component in the quality of baked finish goods, our quality range of provers and retarder provers provide controlled climates with adjustable temperature and humidity settings.

P1R 16 Tray - Single Rack Prover

P2R 32 Tray - 2 Rack Prover

Model P1R

Dimensions

Width	780mm
Depth	1150mm
Height	2280mm

Electrical Requirements

220-240V, 1P+N+E, 50Hz, 15amp

Nett Weight 90kg

Model P2R

Dimensions

Width	1860mm
Depth	1200mm
Height	2390mm

Electrical Requirements

400-415, 3P+N+E, 50Hz, 20amp

Nett Weight 140kg

Additional Information

P2R requires assembly

Dimensions EXCLUDE all protrusions - door handles, drain exits etc...

Minimum ceiling Height required - 2850mm

Units require the following:

Drain Outlet

½" BSP Inlet

moffat.com.au

moffat.co.nz

Australia

moffat.com.au

Moffat Pty Limited

Victoria/Tasmania

740 Springvale Road

Mulgrave, Victoria 3170

Telephone +613-9518 3888

Facsimile +613-9518 3833

vsales@moffat.com.au

New South Wales

Telephone +612-8833 4111

nswsales@moffat.com.au

South Australia

Telephone +613-9518 3888

vsales@moffat.com.au

Queensland

Telephone +617-3630 8600

qldsales@moffat.com.au

Western Australia

Telephone +618-9413 2400

wasales@moffat.com.au

New Zealand

moffat.co.nz

Moffat Limited

Rolleston

45 Illinois Drive

Izone Business Hub

Rolleston 7675

Telephone +64 3-983 6600

Facsimile +64 3-983 6660

sales@moffat.co.nz

Auckland

Telephone +64 9-574 3150

sales@moffat.co.nz

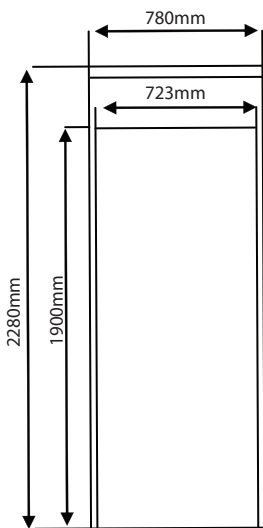

P1R

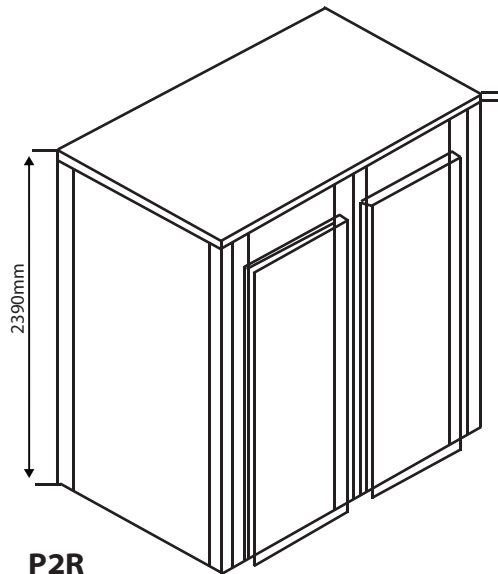

P2R

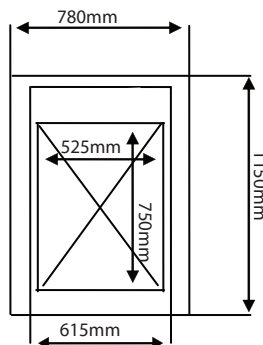

Door opening direction

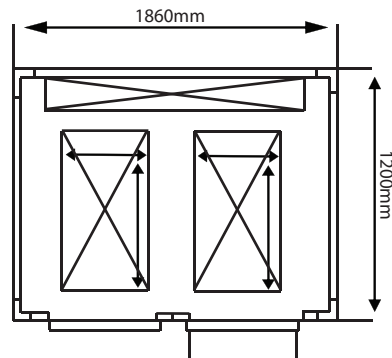

In line with policy to continually develop and improve its products, Moffat Limited reserves the right to change specifications and design without notice.

© Copyright Moffat Ltd
AN.P.01.21

an Ali Group Company



The Spirit of Excellence