



## HHT081E

### Hot holding trolley

#### CONSTRUCTION FEATURES

- Tightness chamber with radiuses corners
- All-around rubber bumpers
- Total thermic insulation with rock or glass wood
- Long lasting front and door seals made up of food grade of high heat resistance
- Removable side racks to facilitate cleaning
- Static heating provided by low consumption wire heating element that coils up all the chamber
- Ergonomic and fully built-in door handle with magnetic closure
- Mounted on four 125 mm diameter castors, two of which with brake
- Ergonomic handle for pushing and guiding
- Easy access to facilitate maintenance and repair

#### FUNCTIONAL FEATURES

- Electronic control of the temperature
- Operating temperature 30°-120°C
- Two adjustable humidity vents on the door
- Chamber with safety thermostat

#### STANDARD SUPPLY

- Removable GN 1/1 tray racks

#### OPTIONS & ACCESSORIES

- Pass-through design



**MODULINESRL**

Via dell'Industria 11, Z.I. San Giacomo di Veglia 31029 Vittorio Veneto (TV) - ITALY  
 tel. +39 0438 5063 - fax +39 0438 912 323 - info@moduline.it - www.moduline.it



# moduline

## TECHNICAL INSTALLATION DIAGRAM

- Electricity supply cable inlet 
- Adjustable vent for release of excess humidity 

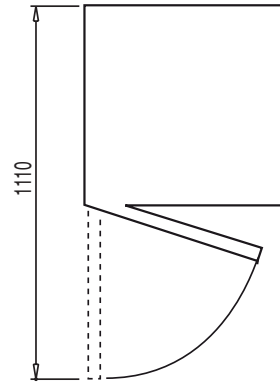
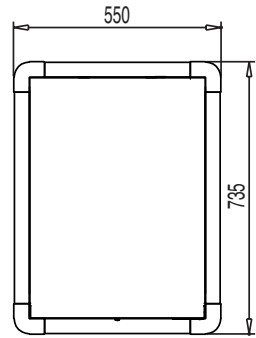
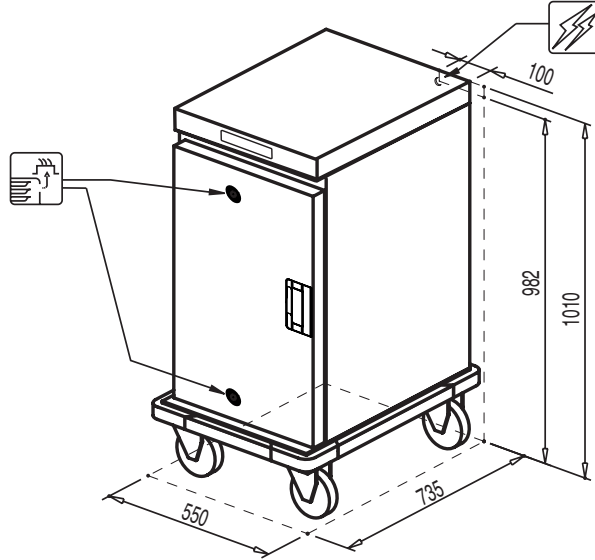

<b>Overall dimensions (W x D x H) - mm</b>	550 x 735 x 1010
<b>Trays capacity</b>	8 x GN 1/1
<b>Tray max. height [mm]</b>	8 x 65 (h) 3 x 150 (h) 2 x 200 (h) + 2 x 65 (h)
<b>Power kW</b>	1
<b>Power supply</b>	AC 230 V / 50 Hz

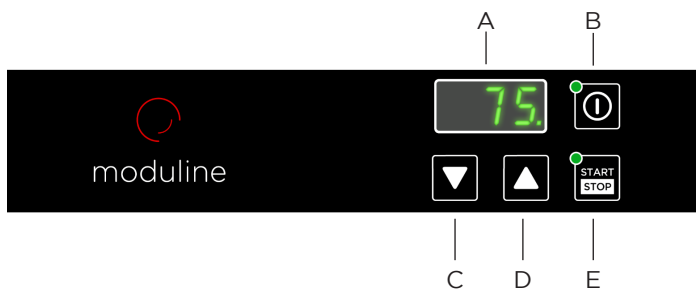

- A Display
- B ON/OFF switch
- C Temperature decrease key
- D Temperature increase key
- E START/STOP key

**MODULINESRL**

Via dell'Industria 11, Z.I. San Giacomo di Veglia 31029 Vittorio Veneto (TV) - ITALY  
tel. +39 0438 5063 - fax +39 0438 912 323 - info@moduline.it - www.moduline.it