

# MERCURY

## SALAMANDER



Mercury Gas Range answers the needs of modern, busy catering establishments for reliable, well-built equipment that offers flexibility, performance, style and value for money. Mercury equipment has been designed with safety, ease of operation and performance as paramount. Mercury has a stylish and robust modular design, constructed of high quality brushed stainless steel, large “cool to touch” dials, large heavy duty adjustable feet and easy to clean and remove accessories.

The Mercury salamander complements the freestanding range of Mercury gas cooking equipment. Two independently controlled infra-red ceramic burners provide excellent performance for menu items requiring grilling and gratinating. Built from stainless steel, including stainless steel removable crumb trays, the unit comes standard with a heavy duty grilling rack that can be manually adjusted to 3 grilling height. The salamander is simple to operate and easy to clean. The salamander is wall mountable but also has the option of installing feet for bench mount requirements.

The Mercury salamander is designed for the most demanding foodservice applications and delivers years of maintenance free operation.

## Product Features

- 900mm wide
- Stainless steel finish
- Dual high performance infrared burners
- Dual controlled burners, with large easy to use control dials
- Independent variable high to low burner settings
- Flame failure as standard
- 3 grilling heights, manually adjusted
- Removable grill rack system, rack supports and crumb tray
- Removable easy-clean crumb tray
- Wall mounting bracket supplied

## Gas Salamander



# INDUSTRY KITCHENS

[www.industrykitchens.com.au](http://www.industrykitchens.com.au) 1800 611 058



1800 013 123 | +61 2 9604 7333  
[sales@middleby.com.au](mailto:sales@middleby.com.au)  
[middleby.com.au](http://middleby.com.au)

**VIC - TAS** - 47 Stubbs Street, Kensington VIC 3031  
**QLD** - U12, 210 Queensport Rd Nth, Murarrie QLD 4172  
**WA** - U2, 9 Meares Way, Canning Vale WA 6155, 08 9456 0559

**HEAD OFFICE  
AND MANUFACTURING PLANT**  
211-217 Woodpark Road, Smithfield NSW 2164

v1\_2023

**MIDDLEBY GOLDSTEIN**

# Gas Salamander

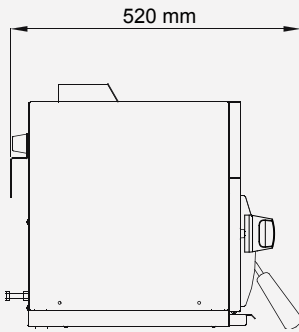
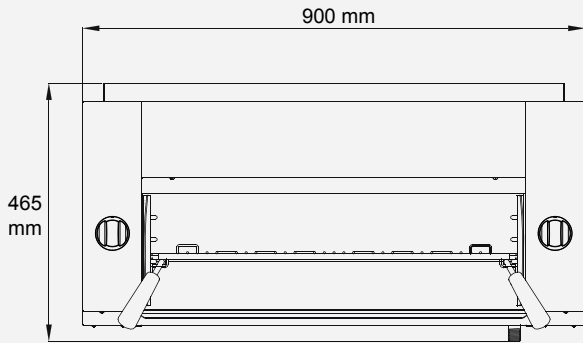

**MERCURY**

Product Code	Infrared Burners	Capacity/ Cooking Area	MJ	Product Overall Dimensions (mm)		
				Width	Depth	Height
<b>MS-36-F</b>	2	630x300 mm	32	900	520	465

- Grill Rack  
620 mm x 285 mm
- Gas connection  
3/4 male, all units supplied with Natural and LP gas regulator
- Net weight 42kg
- Packing data  
935 mm width x 515 mm depth x 635 mm height  
Gross weight 69kg

The dimensions given are reference dimensions only. Due to a continuous program of product improvement, Middleby Food Service Equipment reserves the right to make product changes without notice.

This document contains information that is confidential and proprietary to Middleby Food Service Equipment and shall not be reproduced or transferred to other documents or disclosed to others or used for any purpose other than that for which it was obtained without the expressed written consent of Middleby Food Service Equipment.

 **MIDDLEBY GOLDSTEIN**