

Light Duty Microwaves are ideal for light volume sites recommended for 100 or less uses per day. These dependable ovens are easy to use and are the perfect replacement for domestic ovens in any foodservice operation.

The RCS511TS is a commercial microwave for light duty food service. 100 programmable menu settings and a 4 stage cooking option.

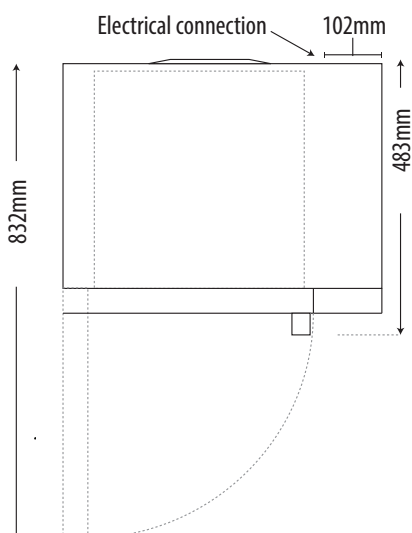
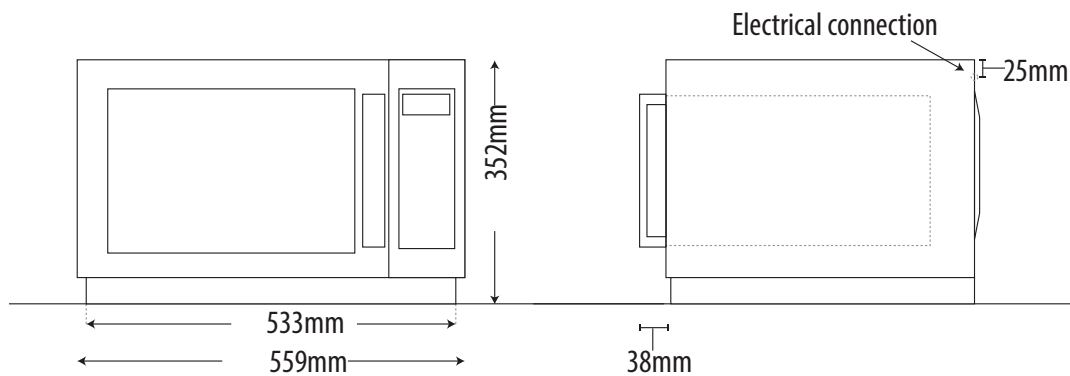

DIMENSIONS

External dimensions: 559W x 483D x 352H mm
Internal cavity: 368W x 381D x 216H mm

POWER SUPPLY

240V 50Hz 10A single phase

TECHNICAL DATA

Power output:	1100 watts
Internal cavity volume:	34 litres
External cabinet finish:	Stainless steel
Internal cavity finish:	Stainless steel with sealed-in ceramic base
Memory programs:	100
Power levels:	5
Product weight:	19 kg
Shipping weight:	22kg
Magnetrons:	1
Clearance:	51mm top & sides
Clearance:	51mm top & sides

SPECIFICATIONS ARE SUBJECT TO CHANGE WITHOUT NOTICE.