

RANGE	CODE	MODEL	FUNCTION
MI - 70	MAMCOOOO660	FR76E1OT	Fryers

ITEM

Twin pan electric fryer 10+10 litres top

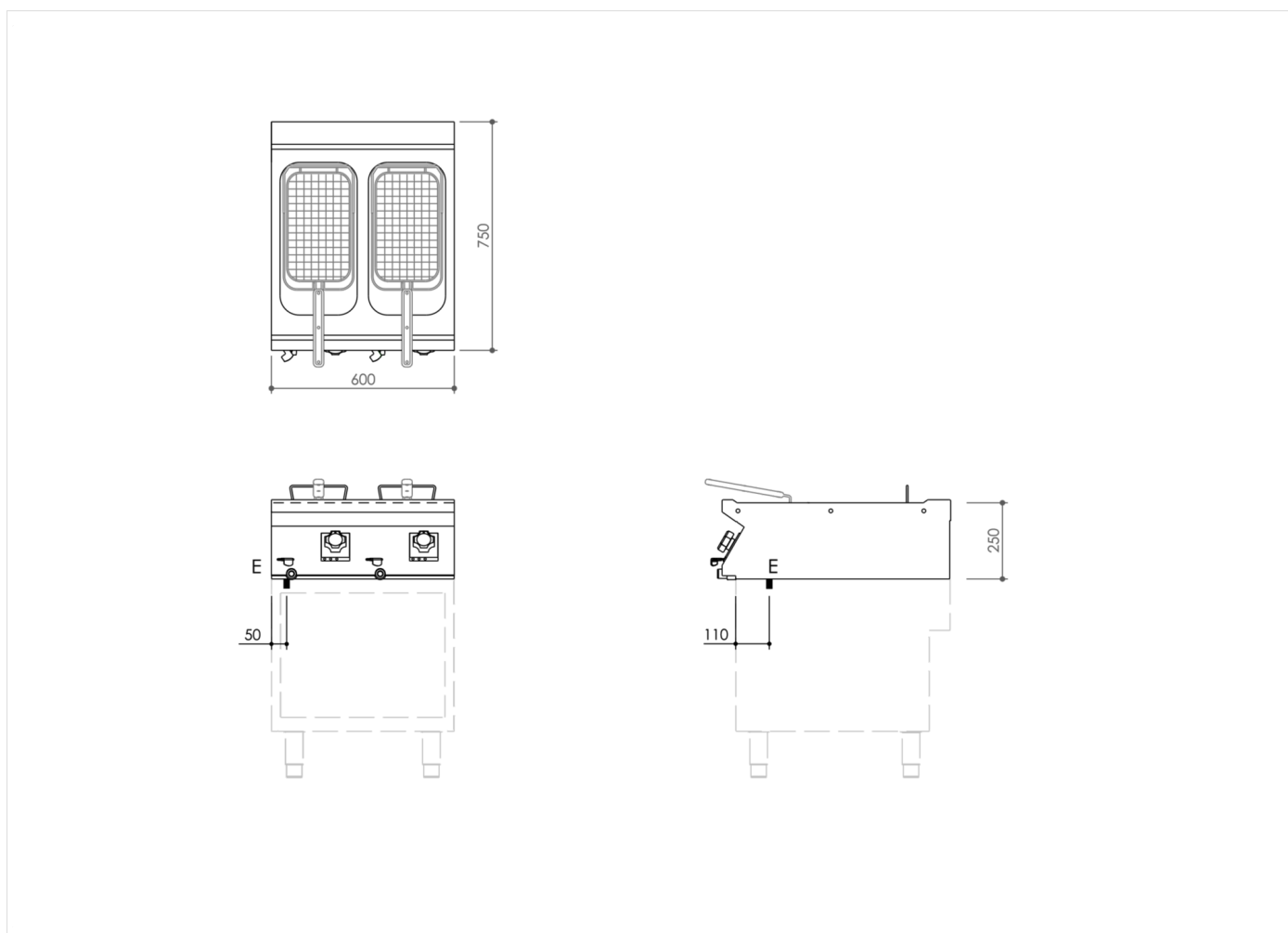

INSTALLATION SPECIFICATIONS

(E) Electrical Connection: VAC400 3N 50 / 60 Hz

