

NEO®

190 SERIES

Undercounter Ice Machines

UYPO190A | UDPO190A



ICE SHAPES



▶ **Half-Dice:** 3/8" x 1 1/8" x 7/8"
(0.95 x 2.86 x 2.22 cm)



▶ **Dice:** 7/8" x 7/8" x 7/8"
(2.22 x 2.22 x 2.22 cm)

SIZE

- ▶ Up to 200 lbs(91 kgs) of daily ice production
- ▶ 26" (66.0 cm) wide, 28.50" (72.4 cm) deep, and 38.50" (97.8 cm) high on 6" (15.24 cm) legs
- ▶ 3.037 ft³ (0.086 m³) cabinet volume
- ▶ 90 lb. (40.0 kgs) ice storage capacity*

*Application capacity based on 90% volume x 33 lbs./ft³ average density of ice

SPECIFICATIONS

Refrigerant R290

BTU Per Hour

- ▶ 3,200 (average)
- ▶ 3,800 (peak)

Compressor: Nominal rating 0.5 HP

Operating Limits:

- ▶ Ambient temperature range: 10° to 37.7°C (50° to 100°F)
- ▶ Water temperature range: 4.4° to 32.2°C (45° to 90°F)
- ▶ Water pressure ice maker
 - ◆ Water in
 - Min. 137.9 kPa (20 psi)
 - Max. 551.1 kPa (80 psi)

Power

230/50/1 Ice machines are factory pre-wired with a 6' (180 cm) power cord only, plug is supplied.

Total Amps

- ▶ 230/50/1 Air Cooled: 2.5 amps

Maximum Fuse Size

- ▶ Air-cooled: 15 amps
- ▶ HACR-type circuit breakers can be used in place of fuses

 **R290 NATURAL REFRIGERANT**



Touchpad

Easy to read and use touchpad - on/off, delay, clean, filter change, full bin, service indicator



Onboard Water Filtration

Integrated water filtration improves machine efficiency and performance while ensuring cleaner, clearer, and great-tasting ice



Air Flow

Front ventilation is ideal for installation under countertops or next to other equipment



Removable Bin

Removable, forward-sliding storage bin allows for easy access to refrigeration components for cleaning and maintenance

BAKER
REFRIGERATION

GEMS: GRN-AIM0057

www.ajbaker.com.au

NEO[®] 190 SERIES

Undercounter Ice Machines

UYPO190A | UDPO190A



INSTALLATION

Recommended clearance for top, sides and back is 5" (12.7 cm) however, there is no minimum clearance required.

- A** 3/8" (0.95 cm) F.P.T. Ice Making Water Inlet
- B** 1/2" (1.27 cm) F.P.T. Ice Making Water Drain
- C** 1/2" (1.27 cm) F.P.T. Bin Water Drain
- D** Electrical Entrance

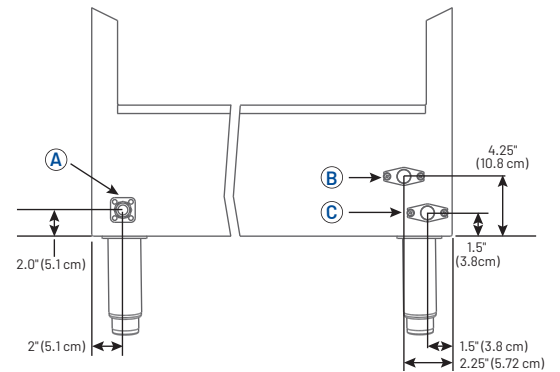
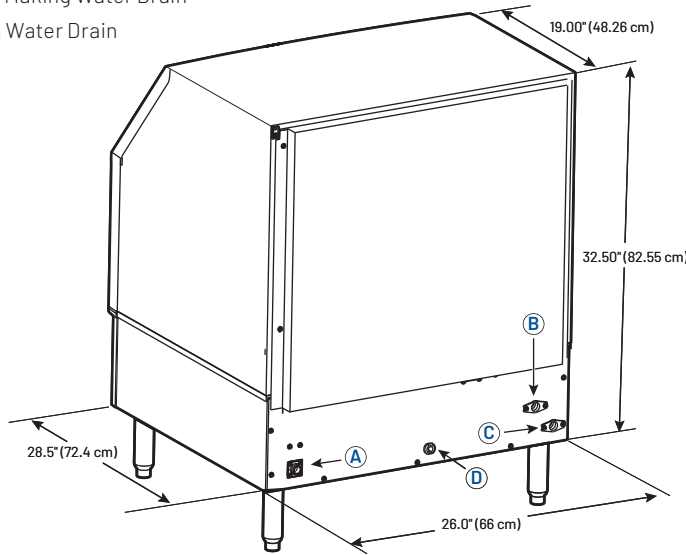

Limited Commercial Warranty

Ice Maker Three (3) years parts and labor

Evaporator Five (5) years parts and labor

Compressor Five (5) years parts, three (3) years labor

SPECIFICATIONS

Model	Ice Shape	Ice Production 24 Hours				Power Usage kWh per 100 lbs. of ice 90° Air/70°F Water (32° Air/21°C Water)	Potable water usage ltr/100 lbs. ice @ 90° Air/70°F Water (32° Air/21°C Water)
		70° Air/50°F Water 21° Air/10°C Water		90° Air/70°F Water 32° Air/21°C Water			
UDPO190A	Dice	181 lbs	82 kgs	127 lbs	58 kgs	5.71	56.5 L
UYPO190A	Half-Dice	186 lbs	84 kgs	132 lbs	60 kgs	5.80	57.25 L

Standard 6" (15.24 cm) adjustable leg. Standard plastic NEO ice scoop included.



GEMS: GRN-AIM0057

www.ajbaker.com.au



2110 South 26th Street | Manitowoc, WI 54220 | United States
+1.920.682.0161 | 920.683.7589 Fax | manitowocice.com

All indicated Pentair trademarks and logos are property of Pentair. Third party registered and unregistered trademarks and logos are the property of their respective owners. ©2025 Pentair. All rights reserved.