

50Hz

iT1500 Ice Cube Machine

iT1500 Ice Cube Machine

Models

IDT1500A



Indigo NXT Series iT1500 Ice Machine on D970C Bin

Designed for operators who know that ice is critical to their business, the Indigo NXT Series ice machine's preventative diagnostics continually monitor itself for reliable ice production. Improvements in cleanliness and programmability make your ice machine easy to own and less expensive to operate.

- **New levels of Performance** - Showcasing an average of 6% lower energy consumption, up to 9% increase in ice production and a 9% reduction in condenser water usage. This translates into lower cost of ownership over the life of your machine.
- **easyTouch® Display** - New icon based touch screen takes the guess work out of owning and operating an ice machine.
- **Multiple Language Capability** - The easyTouch display is available in multiple languages selected in the initial start-up installation Wizard.
- **Programmable Ice Production** - Now its super easy to program your ice machine to be off at certain times of the day to save money with fluctuating electrical rates. Also programmable by daily ice production volume.
- **Easy to Clean Foodzone** - Easy Access front door panel. Removable water-trough, distribution tube, curtain, and sensing probes for fast and efficient cleaning. Select components made with AlphaSan® antimicrobial.
- **Intelligent Diagnostics** - Provides 24 hour preventative maintenance and diagnostic feedback for trouble free operation.
- **Acoustical Ice Sensing Probe** - Unique patented technology allows for reliable operation in challenging water conditions and environments.
- Available **LuminIce® II Growth Inhibitor** - Controls the growth of bacteria and yeast within the Food zone keeping the machine cleaner longer. A new indicator in the display keeps you abreast of the operational status.

Ice Machine Electric

230/50/1

Minimum circuit ampacity:

Air-cooled: 14.9 *1ph*

Maximum fuse size:

Air-cooled: 25 *1ph*



Specifications

Operating Limits:

BTU Per Hour:
23,000 (average),
and 27,000 (peak)

- Ambient Temperature Range: 40° to 110°F (4.4° to 43.3° C)
- Water Temperature Range: 40° to 90°F (4.4° to 32.2° C)

Refrigerant:

R-410 CFC-free

- Water Pressure Ice Maker Water In:
Min. 20 psi (137.9 kPa)
Max. 80 psi (551.1 kPa)

Ice Shape



Dice
7/8" x 7/8" x 7/8"
(2.22 x 2.22 x 2.22 cm)
Cube weight 8.5 g



www.ajbaker.com.au



COMPANY WITH
QUALITY SYSTEM



50Hz

Indigo® NXT™ iT1500 Ice Cube Machine

iT1500 on D970C Storage Bin

- Ⓐ Electrical Entrance (2) Options
- Ⓑ 1/2" (1.27 cm) F.P.T. Water Condenser Outlet (water-cooled units)
- Ⓒ 3/8" (0.95 cm) F.P.T. Water Condenser Inlet (water-cooled units)
- Ⓓ 3/8" (0.95 cm) F.P.T. Ice Making Water Inlet
- Ⓔ 1/2" (1.27 cm) F.P.T. Ice Making Water Drain
- Ⓕ 1/2" (1.27 cm) Auxillary Base Drain Socket
- Ⓖ 3/4" (1.91 cm) Bin Drain

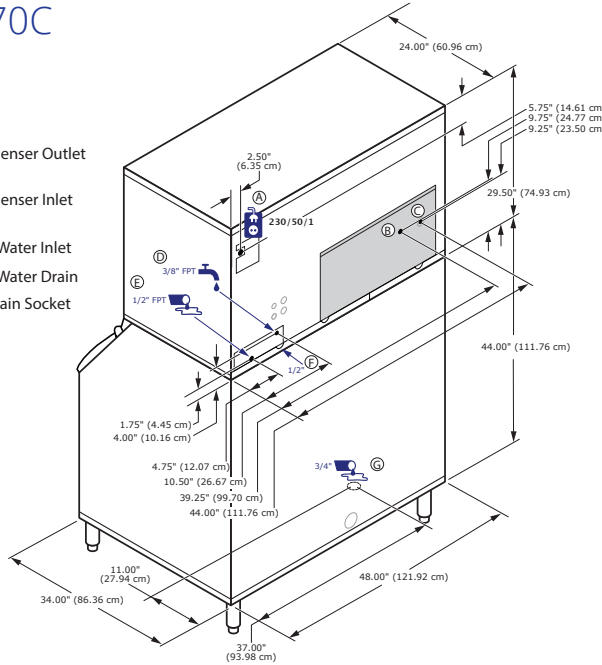

Installation Note

Air Cooled clearance:

Top: 24" (61.0 cm)
Sides: 24" (61.0 cm)
Back: 5" (30.5 cm)

Water Cooled clearance:

Top/Sides: 8" (20.3 cm)
Back: 5" (12.7 cm)

Space-Saving Design



	iT1500 D970C
Height	79.50" 201.90 cm
Width	48.00" 121.92 cm
Depth	34.00" 86.30 cm
Bin Storage	710lbs 322.2 kgs

Height includes adjustable bin legs 6.00" to 8.00", (15.24 to 20.32 cm) set at 6.00" (15.24 cm).

Specifications

Model	Ice Shape	Ice Production 24 Hours		Power Usage kWh 45.4 kg / 100 lbs @ 32°Air / 21°C Water 90°Air / 70°F Water	Potable Water Usage/100 lbs. 45.4 kgs. of Ice
		21°Air / 10°C Water 70°Air / 50°F Water	32°Air / 21°C Water 90°Air / 70°F Water		
IDT1500A	dice	1,725 lbs.	1,146 lbs.	1 Ph	16 Gal.
		782 kgs	521 kgs	4.23	72.7 L

Order separately: Ice storage bin for all units, line-set and remote condenser unit JCT1500 for remote cooled units.
This product is hermetically sealed and contains fluorinated greenhouse gas R404A

www.ajbaker.com.au

Accessories

LuminIce® II Growth Inhibitor
reduces yeast and bacteria growth for a cleaner ice machine.



External Scoop holder

Protect the ice scoop with the NSF approved versatile scoop holder.

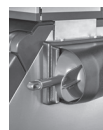

Arctic Pure® Water Filters

Reduces sediment and chlorine odors for better tasting ice.

