



## H 120 Undercounter Ice Machines

Model:  HDE0120A-251Z



H120A Ice Machine

### Standard Features

- Up to 121lbs. (55 kgs.) daily ice production
- 39 lbs. (14kgs.) ice storage capacity
- Only 20" (50cm) wide
- R-134A CFC-free refrigerant
- Front air intake and exhaust
- Stainless steel exterior with the fit and finish of an appliance
- Easy access door, slides up and out of the way
- Easy access air filter designed for longer operation in greasy and dusty environments
- Cleaning and sanitizing technology
- Storage bin liner is fabricated by rotational molding with polyethylene, no seams and better insulation for ice storage
- CFC-free polyethylene foaming technology, better insulation for refrigeration efficiency

### Specifications:

**BTU Per Hour:**  
1,750 (average), 2,600 (peak)

**Compressor:**  
Nominal rating: 1/3 HP

**Refrigerant:**  
R-134A CFC-free

### Ice Machine Electric

220-240/50/1 standard

**Minimum circuit ampacity:**

4.0 amps

**Maximum fuse size:**

15 amps

HACR-type circuit breakers can be used in place of fuses

### Operating Limits:

- Ambient Temperature Range: 1.6°C to 43°C
- Water Temperature Range: 0.6°C to 32°C
- Water Pressure Ice Maker Water In:  
Min. 138kPA  
Max. 551kPA



### Cube Size Available



**Dice**  
7/8" X 7/8" X 7/8"  
2.22 X 2.22 X 2.22 (cm)



H 120 Undercounter Ice Machines



H 120 Undercounter Ice Machines

H120A

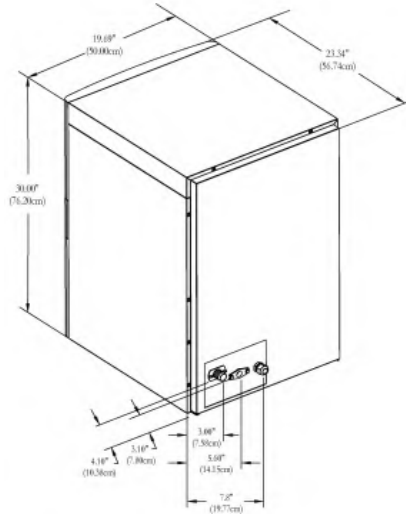

- (A) Electrical Entrance
- (B) 3/4\"(1.91cm)N.P.T.Ice Making Water Inlet
- (C) 1/2\"(1.27cm)F.P.T.Ice Making Water Drain
- (D) 3/4\"(1.91cm)Bin Drain

*Installation Note - Minimum installation clearance:  
Top/sides: 8\"(20.32 cm), back: 5\"(12.70 cm).*

Space-Saving Designs

H120A



Height	31.10" 79.00cm
Width	19.70" 50.00 cm
Depth	22.40" 57.00 cm
Bin Storage	30.9 lbs. 14 kgs.

*Height includes adjustable bin legs 6.00" to 7.00"  
(15.24 cm to 17.78 cm) set at 6.00" (15.24 cm).*

24 - Hour Production

Air-Cooled Units

Air temp	Water temp			
°C	10°	15°	21°	32°
10°	55			
21°	52			
32°			36	
43°				22

Model	Ice Shape	Ice Production 24 Hours		Power Usage KWH/100lbs. @32° C / 21° C	Water Usage L /100lbs. of ice
		21° C Air/10° C Water	32° C Air/21° C Water		
HDE0120A-251Z	dice	115 lbs.	80 lbs.	12.24	140
		52 kgs.	36 kgs.		

Air Flow Front View



Front air intake and exhaust, no side vents

Air Filter



Slides out from left side front without tools, easy to clean, reusable filter protects condenser from lint, grease and dust

Easy Access Door



Easy access door, slides up & out of the way