

Magistar Combi DI Natural Gas Combi Oven 6GN1/1

ITEM # _____

MODEL # _____

NAME # _____

SIS # _____

AIA # _____

**INDUSTRY
KITCHENS**www.industrykitchens.com.au 1800 611 058**218970 (ZCOG61C2U0)**

Magistar Combi DI combi boilerless oven with digital control, 6x1/1GN, gas, programmable, automatic cleaning (Australia)

Short Form Specification

Item No. _____

- Combi oven with digital interface with guided selection.
- Boilerless steaming function to add and retain moisture.
 - AirFlow air distribution system to achieve maximum performance with 5 fan speed levels.
 - HP Automatic Cleaning: Automatic and built-in self cleaning system. 5 automatic cycles (soft, medium, strong, extra strong, rinse-only).
 - Cooking modes: Programs (a maximum of 100 recipes can be stored); Manual (steam, combi and convection cycles); EcoDelta cooking cycle.
 - Automatic backup mode to avoid downtime.
 - USB port to download HACCP data, programs and settings. Connectivity ready.
 - Single sensor core temperature probe.
 - Double-glass door with LED lights.
 - Stainless steel construction throughout.
 - Supplied with n.1 tray rack 1/1 GN, 67 mm pitch.

Main Features

- Digital interface with LED backlight buttons with guided selection.
- Boilerless steaming function to add and retain moisture for high quality, consistent cooking results.
- Dry hot convection cycle (max 300 °C) ideal for low humidity cooking. Automatic moistener (11 settings) for boiler-less steam generation.
- EcoDelta cooking: cooking with food probe maintaining preset temperature difference between the core of the food and the cooking chamber.
- Programs mode: a maximum of 100 recipes can be stored in the oven's memory, to recreate the exact same recipe at any time. 4-step cooking programs also available.
- AirFlow air distribution system to achieve maximum performance in chilling/heating evenness and temperature control thanks to a special design of the chamber combined with high precision variable speed fan.
- Fan with 5 speed levels from 300 to 1500 RPM and reverse rotation for optimal evenness. Fan stops in less than 5 seconds when door is opened.
- Single sensor core temperature probe included.
- Automatic fast cool down and pre-heat function.
- HP Automatic Cleaning: Automatic and built-in self cleaning system. 5 automatic cycles (soft, medium, strong, extra strong, rinse-only).
- Grease Collector: predisposed for integrated grease drain and collection for safer operation (dedicated base as optional accessory).
- USB port to download HACCP data, share cooking programs and configurations. USB port also allows to plug-in sous-vide probe (optional accessory).
- Connectivity ready for real time access to connected appliances from remote and HACCP monitoring (requires optional accessory).
- Back-up mode with self-diagnosis is automatically activated if a failure occurs to avoid downtime.
- 2 different chemical options available: solid and liquid (requires optional accessory).
- Capacity: 6 GN 1/1 trays.
- Connectivity ready for real time access to connected appliances from remote and data monitoring (requires optional accessory – contact the Company for more details).
- [NOT TRANSLATED]

Construction

- Double thermo-glazed door with open frame construction, for cool outside door panel. Swing hinged easy-release inner glass on door for easy cleaning.
- Seamless hygienic internal chamber with all rounded corners for easy cleaning.
- 304 AISI stainless steel construction throughout.
- Front access to control board for easy service.
- IPX 5 spray water protection certification for easy cleaning.
- Supplied with n.1 tray rack 1/1 GN, 67 mm pitch.

APPROVAL: _____

Optional Accessories

• Water softener with cartridge and flow meter (high steam usage)	PNC 920003	<input type="checkbox"/>	• Slide-in rack with handle for 6 & 10 GN 1/1 oven	PNC 922610	<input type="checkbox"/>
• Water softener with salt for ovens with automatic regeneration of resin	PNC 921305	<input type="checkbox"/>	• Open base with tray support for 6 & 10 GN 1/1 oven	PNC 922612	<input type="checkbox"/>
• Wheel kit for 6 & 10 GN 1/1 and 2/1 GN oven base (not for the disassembled one)	PNC 922003	<input type="checkbox"/>	• Cupboard base with tray support for 6 & 10 GN 1/1 oven	PNC 922614	<input type="checkbox"/>
• Pair of AISI 304 stainless steel grids, GN 1/1	PNC 922017	<input type="checkbox"/>	• Hot cupboard base with tray support for 6 & 10 GN 1/1 oven holding GN 1/1 or 400x600mm	PNC 922615	<input type="checkbox"/>
• Pair of grids for whole chicken (8 per grid - 1,2kg each), GN 1/1	PNC 922036	<input type="checkbox"/>	• External connection kit for detergent and rinse aid	PNC 922618	<input type="checkbox"/>
• AISI 304 stainless steel grid, GN 1/1	PNC 922062	<input type="checkbox"/>	• Grease collection kit for GN 1/1-2/1 cupboard base (trolley with 2 tanks, open/close device and drain)	PNC 922619	<input type="checkbox"/>
• Grid for whole chicken (4 per grid - 1,2kg each), GN 1/2	PNC 922086	<input type="checkbox"/>	• Stacking kit for gas 6 GN 1/1 oven placed on gas 6 GN 1/1 oven	PNC 922622	<input type="checkbox"/>
• External side spray unit (needs to be mounted outside and includes support to be mounted on the oven)	PNC 922171	<input type="checkbox"/>	• Stacking kit for gas 6 GN 1/1 oven placed on gas 10 GN 1/1 oven	PNC 922623	<input type="checkbox"/>
• Baking tray for 5 baguettes in perforated aluminum with silicon coating, 400x600x38mm	PNC 922189	<input type="checkbox"/>	• Trolley for slide-in rack for 6 & 10 GN 1/1 oven and blast chiller freezer	PNC 922626	<input type="checkbox"/>
• Baking tray with 4 edges in perforated aluminum, 400x600x20mm	PNC 922190	<input type="checkbox"/>	• Trolley for mobile rack for 2 stacked 6 GN 1/1 ovens on riser	PNC 922628	<input type="checkbox"/>
• Baking tray with 4 edges in aluminum, 400x600x20mm	PNC 922191	<input type="checkbox"/>	• Trolley for mobile rack for 6 GN 1/1 on 6 or 10 GN 1/1 ovens	PNC 922630	<input type="checkbox"/>
• Pair of frying baskets	PNC 922239	<input type="checkbox"/>	• Riser on feet for 2 6 GN 1/1 ovens or a 6 GN 1/1 oven on base	PNC 922632	<input type="checkbox"/>
• AISI 304 stainless steel bakery/pastry grid 400x600mm	PNC 922264	<input type="checkbox"/>	• Riser on wheels for stacked 2x6 GN 1/1 ovens, height 250mm	PNC 922635	<input type="checkbox"/>
• Double-step door opening kit	PNC 922265	<input type="checkbox"/>	• Stainless steel drain kit for 6 & 10 GN oven, dia=50mm	PNC 922636	<input type="checkbox"/>
• Grid for whole chicken (8 per grid - 1,2kg each), GN 1/1	PNC 922266	<input type="checkbox"/>	• Plastic drain kit for 6 & 10 GN oven, dia=50mm	PNC 922637	<input type="checkbox"/>
• Grease collection tray, GN 1/1, H=100 mm	PNC 922321	<input type="checkbox"/>	• Grease collection kit for open base (2 tanks, open/close device and drain)	PNC 922639	<input type="checkbox"/>
• Kit universal skewer rack and 4 long skewers for GN 1/1 ovens	PNC 922324	<input type="checkbox"/>	• Wall support for 6 GN 1/1 oven	PNC 922643	<input type="checkbox"/>
• Universal skewer rack	PNC 922326	<input type="checkbox"/>	• Dehydration tray, GN 1/1, H=20mm	PNC 922651	<input type="checkbox"/>
• 4 long skewers	PNC 922327	<input type="checkbox"/>	• Flat dehydration tray, GN 1/1	PNC 922652	<input type="checkbox"/>
• Smoker for lengthwise and crosswise oven (4 kinds of smoker wood chips are available on request)	PNC 922338	<input type="checkbox"/>	• Open base for 6 & 10 GN 1/1 oven, disassembled	PNC 922653	<input type="checkbox"/>
• Multipurpose hook	PNC 922348	<input type="checkbox"/>	• Bakery/pastry rack kit for 6 GN 1/1 oven with 5 racks 400x600mm and 80mm pitch	PNC 922655	<input type="checkbox"/>
• 4 flanged feet for 6 & 10 GN , 2", 100-130mm	PNC 922351	<input type="checkbox"/>	• Stacking kit for gas 6 GN 1/1 oven placed on 7kg and 15kg crosswise blast chiller freezer	PNC 922657	<input type="checkbox"/>
• Grid for whole duck (8 per grid - 1,8kg each), GN 1/1	PNC 922362	<input type="checkbox"/>	• Heat shield for stacked ovens 6 GN 1/1 on 6 GN 1/1	PNC 922660	<input type="checkbox"/>
• Tray support for 6 & 10 GN 1/1 disassembled open base	PNC 922382	<input type="checkbox"/>	• Heat shield for stacked ovens 6 GN 1/1 on 10 GN 1/1	PNC 922661	<input type="checkbox"/>
• Wall mounted detergent tank holder	PNC 922386	<input type="checkbox"/>	• Heat shield for 6 GN 1/1 oven	PNC 922662	<input type="checkbox"/>
• USB SINGLE POINT PROBE	PNC 922390	<input type="checkbox"/>	• Kit to convert from natural gas to LPG	PNC 922670	<input type="checkbox"/>
• Tray rack with wheels, 6 GN 1/1, 65mm pitch (included)	PNC 922600	<input type="checkbox"/>	• Kit to convert from LPG to natural gas	PNC 922671	<input type="checkbox"/>
• Tray rack with wheels, 5 GN 1/1, 80mm pitch	PNC 922606	<input type="checkbox"/>	• Flue condenser for gas oven	PNC 922678	<input type="checkbox"/>
• Bakery/pastry tray rack with wheels holding 400x600mm grids for 6 GN 1/1 oven and blast chiller freezer, 80mm pitch (5 runners)	PNC 922607	<input type="checkbox"/>	• Fixed tray rack for 6 GN 1/1 and 400x600mm grids	PNC 922684	<input type="checkbox"/>
			• Kit to fix oven to the wall	PNC 922687	<input type="checkbox"/>
			• 4 high adjustable feet for 6 & 10 GN ovens, 100-115MM	PNC 922688	<input type="checkbox"/>
			• Tray support for 6 & 10 GN 1/1 open base	PNC 922690	<input type="checkbox"/>
			• Detergent tank holder for open base	PNC 922699	<input type="checkbox"/>
			• Bakery/pastry runners 400x600mm for 6 & 10 GN 1/1 oven base	PNC 922702	<input type="checkbox"/>
			• Wheels for stacked ovens	PNC 922704	<input type="checkbox"/>

- CHIMNEY ADAPTOR NEEDED IN CASE OF CONVERSION OF 6 GN 1/1 OR 6 GN 2/1 OVENS FROM NATURAL GAS TO LPG PNC 922706
- Mesh grilling grid PNC 922713
- Probe holder for liquids PNC 922714
- Exhaust hood with fan for 6 & 10 GN 1/1 ovens PNC 922728
- Exhaust hood without fan for 6&10 1/1GN ovens PNC 922733
- Fixed tray rack, 5 GN 1/1, 85mm pitch PNC 922740
- 4 high adjustable feet for 6 & 10 GN ovens, 230-290mm PNC 922745
- Tray for traditional static cooking, H=100mm PNC 922746
- Double-face griddle, one side ribbed and one side smooth, 400x600mm PNC 922747
- TROLLEY FOR GREASE COLLECTION KIT PNC 922752
- Water inlet pressure reducer PNC 922773
- EXTENSION FOR CONDENSATION TUBE PNC 922776
- Non-stick universal pan, GN 1/1, H=20mm PNC 925000
- Non-stick universal pan, GN 1/ 1, H=40mm PNC 925001
- Non-stick universal pan, GN 1/1, H=60mm PNC 925002
- Double-face griddle, one side ribbed and one side smooth, GN 1/1 PNC 925003
- Aluminum grill, GN 1/1 PNC 925004
- Frying pan for 8 eggs, pancakes, hamburgers, GN 1/1 PNC 925005
- Flat baking tray with 2 edges, GN 1/1 PNC 925006
- Baking tray for 4 baguettes, GN 1/1 PNC 925007
- Potato baker for 28 potatoes, GN 1/1 PNC 925008
- Non-stick universal pan, GN 1/2, H=20mm PNC 925009
- Non-stick universal pan, GN 1/2, H=40mm PNC 925010
- Non-stick universal pan, GN 1/2, H=60mm PNC 925011
- Compatibility kit for installation on previous base GN 1/1 PNC 930217

Front

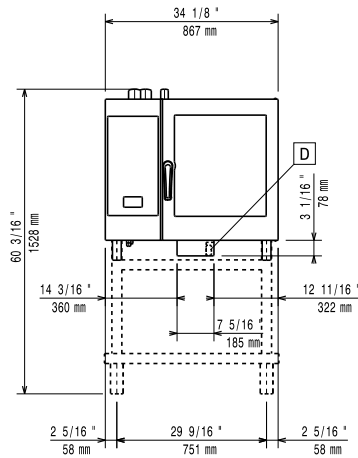

Side

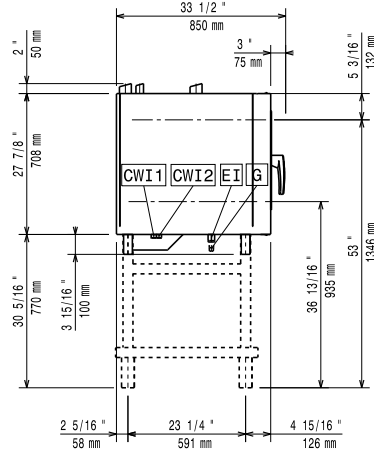

- C-WI-1** = Cold Water inlet 1 **EI** = Electrical inlet (power)
- C-WI-2** = Cold Water Inlet 2 **G** = Gas connection
- D** = Drain
- DO** = Overflow drain pipe

Top

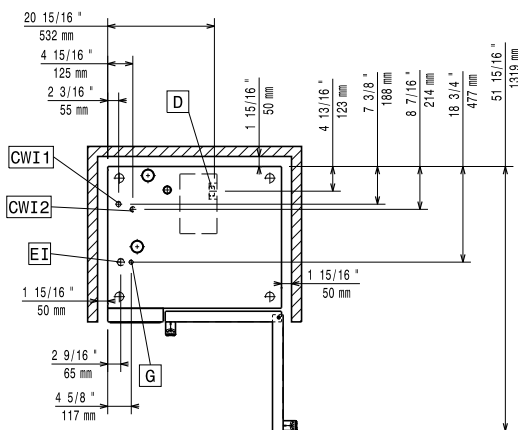

Electric

Supply voltage:
218970 (ZCOG61C2U0) 230-240 V/1 ph/50 Hz
Electrical power, default: 1.1 kW
Electrical power max.: 1.1 kW
Circuit breaker required

Gas

Gas Power: 13 kW
Standard gas delivery: Natural Gas G20
ISO 7/1 gas connection diameter: 1/2" MNPT

LPG:

Total thermal load: 44317 BTU (13 kW)

Water:

Water inlet "FCW" connection: 3/4"
Pressure, bar min/max: 1-6 bar
Drain "D": 50mm
Max inlet water supply temperature: 30 °C
Chlorides: <10 ppm
Conductivity: >50 µS/cm
Electrolux Professional recommends the use of treated water, based on testing of specific water conditions.
Please refer to user manual for detailed water quality information.

Installation:

Clearance: Clearance: 5 cm rear and right hand sides.
Suggested clearance for service access: 50 cm left hand side.

Capacity:

GN: 6 - 1/1 Gastronorm
Max load capacity: 30 kg

Key Information:

Door hinges:
External dimensions, Width: 867 mm
External dimensions, Depth: 775 mm
External dimensions, Height: 808 mm
Net weight: 122.5 kg
Shipping weight: 139.5 kg
Shipping volume: 0.84 m³

Magistar Combi DI
Natural Gas Combi Oven 6GN1/1

The company reserves the right to make modifications to the products without prior notice. All information correct at time of printing.