

**Magistar Combi DI
Electric Combi Oven 6GN2/1**

ITEM # _____

MODEL # _____

NAME # _____

SIS # _____

AIA # _____

**218931 (ZCOE62C2S0)**

Magistar Combi DI combi boilerless oven with digital control, 6x2/1GN, electric, programmable, automatic cleaning (Australia)

Short Form Specification**Item No.** _____

- Combi oven with digital interface with guided selection.
- Boilerless steaming function to add and retain moisture.
 - AirFlow air distribution system to achieve maximum performance with 5 fan speed levels.
 - HP Automatic Cleaning: Automatic and built-in self cleaning system. 5 automatic cycles (soft, medium, strong, extra strong, rinse-only).
 - Cooking modes: Programs (a maximum of 100 recipes can be stored); Manual (steam, combi and convection cycles); EcoDelta cooking cycle.
 - Automatic backup mode to avoid downtime.
 - USB port to download HACCP data, programs and settings. Connectivity ready.
 - Single sensor core temperature probe.
 - Double-glass door with LED lights.
 - Stainless steel construction throughout.
 - Supplied with n.1 tray rack 2/1 GN, 67 mm pitch.

Main Features

- Digital interface with LED backlight buttons with guided selection.
- Boilerless steaming function to add and retain moisture for high quality, consistent cooking results.
- Dry hot convection cycle (max 300 °C) ideal for low humidity cooking. Automatic moistener (11 settings) for boiler-less steam generation.
- EcoDelta cooking: cooking with food probe maintaining preset temperature difference between the core of the food and the cooking chamber.
- Programs mode: a maximum of 100 recipes can be stored in the oven's memory, to recreate the exact same recipe at any time. 4-step cooking programs also available.
- AirFlow air distribution system to achieve maximum performance in chilling/heating evenness and temperature control thanks to a special design of the chamber combined with high precision variable speed fan.
- Fan with 5 speed levels from 300 to 1500 RPM and reverse rotation for optimal evenness. Fan stops in less than 5 seconds when door is opened.
- Single sensor core temperature probe included.
- Automatic fast cool down and pre-heat function.
- HP Automatic Cleaning: Automatic and built-in self cleaning system. 5 automatic cycles (soft, medium, strong, extra strong, rinse-only).
- Grease Collector: predisposed for integrated grease drain and collection for safer operation (dedicated base as optional accessory).
- USB port to download HACCP data, share cooking programs and configurations. USB port also allows to plug-in sous-vide probe (optional accessory).
- Connectivity ready for real time access to connected appliances from remote and HACCP monitoring (requires optional accessory).
- Back-up mode with self-diagnosis is automatically activated if a failure occurs to avoid downtime.
- 2 different chemical options available: solid and liquid (requires optional accessory).
- Capacity: 6 GN 2/1 or 12 GN 1/1 trays.
- Connectivity ready for real time access to connected appliances from remote and data monitoring (requires optional accessory – contact the Company for more details).
- [NOT TRANSLATED]

Construction

- Double thermo-glazed door with open frame construction, for cool outside door panel. Swing hinged easy-release inner glass on door for easy cleaning.
- Seamless hygienic internal chamber with all rounded corners for easy cleaning.
- 304 AISI stainless steel construction throughout.
- Front access to control board for easy service.
- IPX 5 spray water protection certification for easy cleaning.
- Supplied with n.1 tray rack 2/1 GN, 67 mm pitch.

APPROVAL: _____

Optional Accessories

• Water softener with cartridge and flow meter (high steam usage)	PNC 920003	<input type="checkbox"/>	• External connection kit for detergent and rinse aid	PNC 922618	<input type="checkbox"/>
• Water softener with salt for ovens with automatic regeneration of resin	PNC 921305	<input type="checkbox"/>	• Stacking kit for electric 6 GN 2/1 oven placed on electric 10 GN 2/1 oven	PNC 922621	<input type="checkbox"/>
• Wheel kit for 6 & 10 GN 1/1 and 2/1 GN oven base (not for the disassembled one)	PNC 922003	<input type="checkbox"/>	• Trolley for slide-in rack for 6 & 10 GN 2/1 oven and blast chiller freezer	PNC 922627	<input type="checkbox"/>
• Pair of AISI 304 stainless steel grids, GN 1/1	PNC 922017	<input type="checkbox"/>	• Trolley for mobile rack for 2 stacked 6 GN 2/1 ovens on riser	PNC 922629	<input type="checkbox"/>
• Pair of grids for whole chicken (8 per grid - 1,2kg each), GN 1/1	PNC 922036	<input type="checkbox"/>	• Trolley for mobile rack for 6 GN 2/1 on 6 or 10 GN 2/1 ovens	PNC 922631	<input type="checkbox"/>
• AISI 304 stainless steel grid, GN 1/1	PNC 922062	<input type="checkbox"/>	• Riser on feet for stacked 2x6 GN 1/1 ovens	PNC 922633	<input type="checkbox"/>
• AISI 304 stainless steel grid, GN 2/1	PNC 922076	<input type="checkbox"/>	• Riser on wheels for stacked 2x6 GN 2/1 ovens, height 250mm	PNC 922634	<input type="checkbox"/>
• External side spray unit (needs to be mounted outside and includes support to be mounted on the oven)	PNC 922171	<input type="checkbox"/>	• Stainless steel drain kit for 6 & 10 GN oven, dia=50mm	PNC 922636	<input type="checkbox"/>
• Pair of AISI 304 stainless steel grids, GN 2/1	PNC 922175	<input type="checkbox"/>	• Plastic drain kit for 6 & 10 GN oven, dia=50mm	PNC 922637	<input type="checkbox"/>
• Baking tray for 5 baguettes in perforated aluminum with silicon coating, 400x600x38mm	PNC 922189	<input type="checkbox"/>	• Trolley with 2 tanks for grease collection	PNC 922638	<input type="checkbox"/>
• Baking tray with 4 edges in perforated aluminum, 400x600x20mm	PNC 922190	<input type="checkbox"/>	• Grease collection kit for open base (2 tanks, open/close device and drain)	PNC 922639	<input type="checkbox"/>
• Baking tray with 4 edges in aluminum, 400x600x20mm	PNC 922191	<input type="checkbox"/>	• Wall support for 6 GN 2/1 oven	PNC 922644	<input type="checkbox"/>
• Pair of frying baskets	PNC 922239	<input type="checkbox"/>	• Dehydration tray, GN 1/1, H=20mm	PNC 922651	<input type="checkbox"/>
• AISI 304 stainless steel bakery/pastry grid 400x600mm	PNC 922264	<input type="checkbox"/>	• Flat dehydration tray, GN 1/1	PNC 922652	<input type="checkbox"/>
• Double-step door opening kit	PNC 922265	<input type="checkbox"/>	• Open base for 6 & 10 GN 2/1 oven, disassembled	PNC 922654	<input type="checkbox"/>
• Grid for whole chicken (8 per grid - 1,2kg each), GN 1/1	PNC 922266	<input type="checkbox"/>	• Heat shield for 6 GN 2/1 oven	PNC 922665	<input type="checkbox"/>
• Kit universal skewer rack and 6 short skewers for Lengthwise GN 2/1 and Crosswise ovens	PNC 922325	<input type="checkbox"/>	• Heat shield-stacked for ovens 6 GN 2/1 on 6 GN 2/1	PNC 922666	<input type="checkbox"/>
• Universal skewer rack	PNC 922326	<input type="checkbox"/>	• Heat shield-stacked for ovens 6 GN 2/1 on 10 GN 2/1	PNC 922667	<input type="checkbox"/>
• 6 short skewers	PNC 922328	<input type="checkbox"/>	• Fixed tray rack, 5 GN 2/1, 85mm pitch	PNC 922681	<input type="checkbox"/>
• Smoker for lengthwise and crosswise oven (4 kinds of smoker wood chips are available on request)	PNC 922338	<input type="checkbox"/>	• Kit to fix oven to the wall	PNC 922687	<input type="checkbox"/>
• Multipurpose hook	PNC 922348	<input type="checkbox"/>	• 4 high adjustable feet for 6 & 10 GN ovens, 100-115MM	PNC 922688	<input type="checkbox"/>
• 4 flanged feet for 6 & 10 GN , 2", 100-130mm	PNC 922351	<input type="checkbox"/>	• Tray support for 6 & 10 GN 2/1 open base	PNC 922692	<input type="checkbox"/>
• Grease collection tray, GN 2/1, H=60 mm	PNC 922357	<input type="checkbox"/>	• Detergent tank holder for open base	PNC 922699	<input type="checkbox"/>
• Grid for whole duck (8 per grid - 1,8kg each), GN 1/1	PNC 922362	<input type="checkbox"/>	• Tray rack with wheels, 6 GN 2/1, 65mm pitch (included)	PNC 922700	<input type="checkbox"/>
• Tray support for 6 & 10 GN 2/1 disassembled open base	PNC 922384	<input type="checkbox"/>	• Mesh grilling grid	PNC 922713	<input type="checkbox"/>
• Wall mounted detergent tank holder	PNC 922386	<input type="checkbox"/>	• Probe holder for liquids	PNC 922714	<input type="checkbox"/>
• USB SINGLE POINT PROBE	PNC 922390	<input type="checkbox"/>	• Odourless hood with fan for 6 & 10 GN 2/1 electric ovens	PNC 922719	<input type="checkbox"/>
• Slide-in rack with handle for 6 & 10 GN 2/1 oven	PNC 922605	<input type="checkbox"/>	• Condensation hood with fan for 6 & 10 GN 2/1 electric oven	PNC 922724	<input type="checkbox"/>
• Tray rack with wheels, 5 GN 2/1, 80mm pitch	PNC 922611	<input type="checkbox"/>	• 4 high adjustable feet for 6 & 10 GN ovens, 230-290mm	PNC 922745	<input type="checkbox"/>
• Open base with tray support for 6 & 10 GN 2/1 oven	PNC 922613	<input type="checkbox"/>	• Tray for traditional static cooking, H=100mm	PNC 922746	<input type="checkbox"/>
• Cupboard base with tray support for 6 & 10 GN 2/1 oven	PNC 922616	<input type="checkbox"/>	• Double-face griddle, one side ribbed and one side smooth, 400x600mm	PNC 922747	<input type="checkbox"/>
• Hot cupboard base with tray support for 6 & 10 GN 2/1 oven holding GN 1/1 or 400x600mm	PNC 922617	<input type="checkbox"/>	• TROLLEY FOR GREASE COLLECTION KIT	PNC 922752	<input type="checkbox"/>
			• Water inlet pressure reducer	PNC 922773	<input type="checkbox"/>
			• KIT FOR INSTALLATION OF ELECTRIC POWER PEAK MANAGEMENT SYSTEM-6-10 GN OVENS	PNC 922774	<input type="checkbox"/>
			• Non-stick universal pan, GN 1/1, H=20mm	PNC 925000	<input type="checkbox"/>
			• Non-stick universal pan, GN 1/ 1, H=40mm	PNC 925001	<input type="checkbox"/>
			• Non-stick universal pan, GN 1/1, H=60mm	PNC 925002	<input type="checkbox"/>



Magistar Combi DI Electric Combi Oven 6GN2/1

- Double-face griddle, one side ribbed and one side smooth, GN 1/1 PNC 925003
- Aluminum grill, GN 1/1 PNC 925004
- Frying pan for 8 eggs, pancakes, hamburgers, GN 1/1 PNC 925005
- Flat baking tray with 2 edges, GN 1/1 PNC 925006
- Potato baker for 28 potatoes, GN 1/1 PNC 925008
- Compatibility kit for installation on previous base GN 2/1 PNC 930218



Magistar Combi DI Electric Combi Oven 6GN2/1

The company reserves the right to make modifications to the products without prior notice. All information correct at time of printing.

2024.01.25

Front

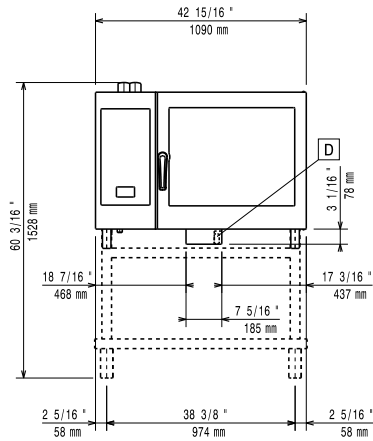

Side

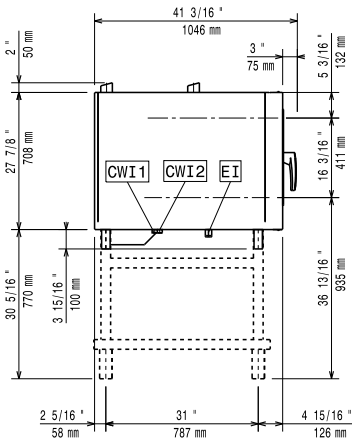

- C-** = Cold Water inlet 1 **EI** = Electrical inlet (power)
- WI-1** = Cold Water Inlet 2
- C-2** = Cold Water Inlet 2
- WI-2** = Cold Water Inlet 2
- D** = Drain
- DO** = Overflow drain pipe

Top

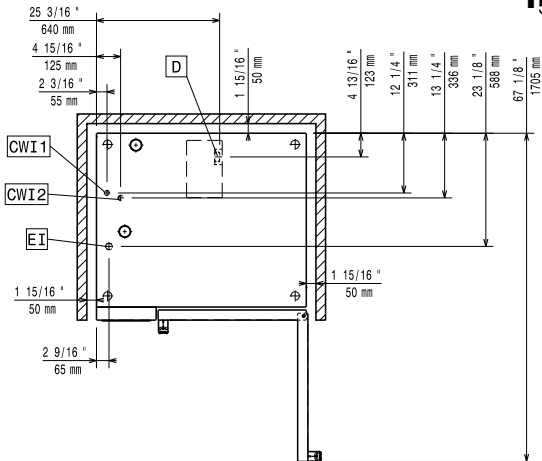

Electric

- Supply voltage:** 218931 (ZCOE62C2S0) 400-430 V/3N ph/50-60 Hz
- Electrical power, default:** 21.4 kW
- Electrical power max.:** 22.3 kW
- Circuit breaker required**

Water:

- Water inlet "FCW" connection:** 3/4"
 - Pressure, bar min/max:** 1-6 bar
 - Drain "D":** 50mm
 - Max inlet water supply temperature:** 30 °C
 - Chlorides:** <10 ppm
 - Conductivity:** >50 µS/cm
- Electrolux Professional* recommends the use of treated water, based on testing of specific water conditions.
Please refer to user manual for detailed water quality information.

Installation:

- Clearance:** Clearance: 5 cm rear and right hand sides.
- Suggested clearance for service access:** 50 cm left hand side.

Capacity:

- GN:** 6 - 2/1 Gastronorm
- Max load capacity:** 60 kg

Key Information:

- Door hinges:**
- External dimensions, Width:** 1090 mm
- External dimensions, Depth:** 971 mm
- External dimensions, Height:** 808 mm
- Net weight:** 147.5 kg
- Shipping weight:** 170.5 kg
- Shipping volume:** 1.27 m³