

**Magistar Combi TS**  
**Electric Combi Oven 10GN1/1**

ITEM # \_\_\_\_\_

MODEL # \_\_\_\_\_

NAME # \_\_\_\_\_

SIS # \_\_\_\_\_

AIA # \_\_\_\_\_



**218732 (ZCOE101T2S0)** Magistar Combi TS combi boiler oven with touch screen control, 10x1/1GN, electric, 3 cooking modes (automatic, recipe program, manual), automatic cleaning, boiler in AISI304 (Australia)

## Short Form Specification

### Item No.

- Combi oven with high resolution full touch screen interface, multilanguage.
- Boilerless steaming function to add and retain moisture.
  - AirFlow air distribution system to achieve maximum performance with 7 fan speed levels.
  - HP Automatic Cleaning: Automatic and built-in self cleaning system. 5 automatic cycles (soft, medium, strong, extra strong, rinse-only) and economizer functions to save energy, water, detergent and rinse aid.
  - Cooking modes: Programs (a maximum of 1000 recipes can be stored and organized in 16 different categories); Manual (steam, combi and convection cycles); EcoDelta cooking cycle.
  - Special functions: MultiTimer cooking, Cooking Optimizer to cut running costs, Make-it-Mine to customize interface, SoloMio to customize homepage, agenda Calendar, automatic backup mode to avoid downtime.
  - USB port to download HACCP data, programs and settings. Connectivity ready.
  - Single sensor core temperature probe.
  - Double-glass door with LED lights.
  - Stainless steel construction throughout.
  - Supplied with n.1 tray rack 1/1 GN, 63 mm pitch.

## Main Features

- High resolution full touch screen interface (translated in more than 30 languages) - color-blind friendly panel.
- Built-in steam generator for highly precise humidity and temperature control according to the chosen settings.
- Real humidity control based upon Lambda Sensor to automatically recognize quantity and size of food for consistent quality results.
- Dry, hot convection cycle (25 °C - 300 °C): ideal for low humidity cooking.
- Combination cycle (25 °C - 300 °C): combining convected heat and steam to obtain humidity controlled cooking environment, accelerating the cooking process and reducing weight loss.
- Low temperature Steam cycle (25 °C - 99 °C): ideal for sous-vide, re-thermalization and delicate cooking. Steam cycle (100 °C): seafood and vegetables. High temperature steam (25 °C - 130 °C).
- Automatic mode including 9 food families (meat, poultry, fish, vegetables, pasta/rice, eggs, savory and sweet bakery, bread, dessert) with 100+ different pre-installed variants. Through Automatic Sensing Phase the oven optimizes the cooking process according to size, quantity and type of food loaded to achieve the selected cooking result. Real time overview of the cooking parameters. Possibility to personalize and save up to 70 variants per family.
- Special Cycles: - Regeneration (ideal for banqueting on plate or rethermalizing on tray), - Low Temperature Cooking (to minimize weight loss and maximize food quality), - Proving cycle, - EcoDelta cooking, cooking with food probe maintaining preset temperature difference between the core of the food and the cooking chamber, - Sous-vide cooking, - Static Combi (to reproduce traditional cooking from static oven), - Pasteurization of pasta, - Dehydration cycles (ideal for drying fruits, vegetables, meats, seafood), - Food Safe Control (to automatically monitor safety of cooking process in compliance with HACCP hygienic standards), - Advanced Food Safe Control (to drive the cooking with pasteurization factor).
- Programs mode: a maximum of 1000 recipes can be stored in the oven's memory, to recreate the exact same recipe at any time. The recipes can be group in 16 different categories to better organize the menu. 16-step cooking programs also available.
- MultiTimer function to manage up to 20 different cooking cycles at the same time, improving flexibility and ensuring excellent cooking results. Can be saved up to 200 MultiTimer programs.
- AirFlow air distribution system to achieve maximum performance in chilling/heating evenness and temperature control thanks to a special design of the chamber combined with high precision variable speed fan.
- Fan with 7 speed levels from 300 to 1500 RPM and reverse rotation for optimal evenness. Fan stops in less than 5 seconds when door is opened.
- 6-point multi sensor core temperature probe for maximum precision and food safety.
- Pictures upload for full customization of cooking cycles.

### APPROVAL:

- Automatic fast cool down and pre-heat function.
- Make-it-mine feature to allow full personalization or locking of the user interface.
- SoloMio lets the user group the favorite functions in the homepage for immediate access.
- Calendar works as an agenda where the user can plan the daily work and receive personalized alerts for each task.
- Grease Collector: predisposed for integrated grease drain and collection for safer operation (dedicated base as optional accessory).
- USB port to download HACCP data, share cooking programs and configurations. USB port also allows to plug-in sous-vide probe (optional accessory).
- Connectivity ready for real time access to connected appliances from remote and HACCP monitoring (requires optional accessory).
- Trainings and guidances supporting materials easily accessible by scanning QR-Code with any mobile device.
- Back-up mode with self-diagnosis is automatically activated if a failure occurs to avoid downtime.
- Automatic consumption visualization at the end of the cycle.
- 2 different chemical options available: solid and liquid (requires optional accessory).
- Capacity: 10 GN 1/1 trays.
- Connectivity ready for real time access to connected appliances from remote and data monitoring (requires optional accessory – contact the Company for more details).
- [NOT TRANSLATED]

## Construction

- Double thermo-glazed door with open frame construction, for cool outside door panel. Swing hinged easy-release inner glass on door for easy cleaning.
- Seamless hygienic internal chamber with all rounded corners for easy cleaning.
- 304 AISI stainless steel construction throughout.
- Front access to control board for easy service.
- Integrated spray gun with automatic retracting system for fast rinsing.
- IPX 5 spray water protection certification for easy cleaning.
- Supplied with n.1 tray rack 1/1 GN, 67 mm pitch.

## Sustainability

- Reduced power function for customized slow cooking cycles.
- HP Automatic Cleaning: Automatic and built-in self cleaning system with integrated descale of the steam generator. 5 automatic cycles (soft, medium, strong, extra strong, rinse-only) and green functions to save energy, water, detergent and rinse aid. Also programmable with delayed start.
- Cooking Optimizer function organizes the cooking sequence of the chosen cycles optimizing the work in the kitchen from a time and energy efficiency point of view.

## Optional Accessories

- Water softener with cartridge and flow meter (high steam usage) PNC 920003
- Water softener with salt for ovens with automatic regeneration of resin PNC 921305
- Wheel kit for 6 & 10 GN 1/1 and 2/1 GN oven base (not for the disassembled one) PNC 922003
- Pair of AISI 304 stainless steel grids, GN 1/1 PNC 922017

- Pair of grids for whole chicken (8 per grid - 1,2kg each), GN 1/1 PNC 922036
- AISI 304 stainless steel grid, GN 1/1 PNC 922062
- Grid for whole chicken (4 per grid - 1,2kg each), GN 1/2 PNC 922086
- External side spray unit (needs to be mounted outside and includes support to be mounted on the oven) PNC 922171
- Baking tray for 5 baguettes in perforated aluminum with silicon coating, 400x600x38mm PNC 922189
- Baking tray with 4 edges in perforated aluminum, 400x600x20mm PNC 922190
- Baking tray with 4 edges in aluminum, 400x600x20mm PNC 922191
- Pair of frying baskets PNC 922239
- AISI 304 stainless steel bakery/pastry grid 400x600mm PNC 922264
- Double-step door opening kit PNC 922265
- Grid for whole chicken (8 per grid - 1,2kg each), GN 1/1 PNC 922266
- USB probe for sous-vide cooking PNC 922281
- Grease collection tray, GN 1/1, H=100 mm PNC 922321
- Kit universal skewer rack and 4 long skewers for GN 1/1 ovens PNC 922324
- Universal skewer rack PNC 922326
- 4 long skewers PNC 922327
- Multipurpose hook PNC 922348
- 4 flanged feet for 6 & 10 GN , 2", 100-130mm PNC 922351
- Grid for whole duck (8 per grid - 1,8kg each), GN 1/1 PNC 922362
- Thermal cover for 10 GN 1/1 oven and blast chiller freezer PNC 922364
- Tray support for 6 & 10 GN 1/1 disassembled open base PNC 922382
- Wall mounted detergent tank holder PNC 922386
- USB SINGLE POINT PROBE PNC 922390
- Tray rack with wheels 10 GN 1/1, 65mm pitch (std) PNC 922601
- Tray rack with wheels, 8 GN 1/1, 80mm pitch PNC 922602
- Bakery/pastry tray rack with wheels 400x600mm for 10 GN 1/1 oven and blast chiller freezer, 80mm pitch (8 runners) PNC 922608
- Slide-in rack with handle for 6 & 10 GN 1/1 oven PNC 922610
- Open base with tray support for 6 & 10 GN 1/1 oven PNC 922612
- Cupboard base with tray support for 6 & 10 GN 1/1 oven PNC 922614
- Hot cupboard base with tray support for 6 & 10 GN 1/1 oven holding GN 1/1 or 400x600mm PNC 922615
- External connection kit for detergent and rinse aid PNC 922618
- Grease collection kit for GN 1/1-2/1 cupboard base (trolley with 2 tanks, open/close device and drain) PNC 922619
- Stacking kit for electric 6+6 GN 1/1 ovens or electric 6+10 GN 1/1 GN ovens PNC 922620

• Trolley for slide-in rack for 6 & 10 GN 1/1 oven and blast chiller freezer	PNC 922626	<input type="checkbox"/>	• Double-face griddle, one side ribbed and one side smooth, 400x600mm	PNC 922747	<input type="checkbox"/>
• Trolley for mobile rack for 6 GN 1/1 on 6 or 10 GN 1/1 ovens	PNC 922630	<input type="checkbox"/>	• TROLLEY FOR GREASE COLLECTION KIT	PNC 922752	<input type="checkbox"/>
• Stainless steel drain kit for 6 & 10 GN oven, dia=50mm	PNC 922636	<input type="checkbox"/>	• Water inlet pressure reducer	PNC 922773	<input type="checkbox"/>
• Plastic drain kit for 6 & 10 GN oven, dia=50mm	PNC 922637	<input type="checkbox"/>	• KIT FOR INSTALLATION OF ELECTRIC POWER PEAK MANAGEMENT SYSTEM-6-10 GN OVENS	PNC 922774	<input type="checkbox"/>
• Trolley with 2 tanks for grease collection	PNC 922638	<input type="checkbox"/>	• Non-stick universal pan, GN 1/1, H=20mm	PNC 925000	<input type="checkbox"/>
• Grease collection kit for open base (2 tanks, open/close device and drain)	PNC 922639	<input type="checkbox"/>	• Non-stick universal pan, GN 1/1, H=40mm	PNC 925001	<input type="checkbox"/>
• Wall support for 10 GN 1/1 oven	PNC 922645	<input type="checkbox"/>	• Non-stick universal pan, GN 1/1, H=60mm	PNC 925002	<input type="checkbox"/>
• Banquet rack with wheels holding 30 plates for 10 GN 1/1 oven and blast chiller freezer, 65mm pitch	PNC 922648	<input type="checkbox"/>	• Double-face griddle, one side ribbed and one side smooth, GN 1/1	PNC 925003	<input type="checkbox"/>
• Banquet rack with wheels holding 23 plates for 10 GN 1/1 oven and blast chiller freezer, 85mm pitch	PNC 922649	<input type="checkbox"/>	• Aluminum grill, GN 1/1	PNC 925004	<input type="checkbox"/>
• Dehydration tray, GN 1/1, H=20mm	PNC 922651	<input type="checkbox"/>	• Frying pan for 8 eggs, pancakes, hamburgers, GN 1/1	PNC 925005	<input type="checkbox"/>
• Flat dehydration tray, GN 1/1	PNC 922652	<input type="checkbox"/>	• Flat baking tray with 2 edges, GN 1/1	PNC 925006	<input type="checkbox"/>
• Open base for 6 & 10 GN 1/1 oven, disassembled	PNC 922653	<input type="checkbox"/>	• Baking tray for 4 baguettes, GN 1/1	PNC 925007	<input type="checkbox"/>
• Bakery/pastry rack kit for 10 GN 1/1 oven with 8 racks 400x600mm and 80mm pitch	PNC 922656	<input type="checkbox"/>	• Potato baker for 28 potatoes, GN 1/1	PNC 925008	<input type="checkbox"/>
• Heat shield for stacked ovens 6 GN 1/1 on 10 GN 1/1	PNC 922661	<input type="checkbox"/>	• Non-stick universal pan, GN 1/2, H=20mm	PNC 925009	<input type="checkbox"/>
• Heat shield for 10 GN 1/1 oven	PNC 922663	<input type="checkbox"/>	• Non-stick universal pan, GN 1/2, H=40mm	PNC 925010	<input type="checkbox"/>
• Fixed tray rack for 10 GN 1/1 and 400x600mm grids	PNC 922685	<input type="checkbox"/>	• Non-stick universal pan, GN 1/2, H=60mm	PNC 925011	<input type="checkbox"/>
• Kit to fix oven to the wall	PNC 922687	<input type="checkbox"/>	• Compatibility kit for installation on previous base GN 1/1	PNC 930217	<input type="checkbox"/>
• 4 high adjustable feet for 6 & 10 GN ovens, 100-115MM	PNC 922688	<input type="checkbox"/>			
• Tray support for 6 & 10 GN 1/1 open base	PNC 922690	<input type="checkbox"/>			
• Reinforced tray rack with wheels, lowest support dedicated to a grease collection tray for 10 GN 1/1 oven, 64mm pitch	PNC 922694	<input type="checkbox"/>			
• Detergent tank holder for open base	PNC 922699	<input type="checkbox"/>			
• Bakery/pastry runners 400x600mm for 6 & 10 GN 1/1 oven base	PNC 922702	<input type="checkbox"/>			
• Wheels for stacked ovens	PNC 922704	<input type="checkbox"/>			
• Spit for lamb or suckling pig (up to 12kg) for GN 1/1 ovens	PNC 922709	<input type="checkbox"/>			
• Mesh grilling grid	PNC 922713	<input type="checkbox"/>			
• Probe holder for liquids	PNC 922714	<input type="checkbox"/>			
• Odourless hood with fan for 6 & 10 GN 1/1 electric ovens	PNC 922718	<input type="checkbox"/>			
• Condensation hood with fan for 6 & 10 GN 1/1 electric oven	PNC 922723	<input type="checkbox"/>			
• Exhaust hood with fan for 6 & 10 GN 1/1 ovens	PNC 922728	<input type="checkbox"/>			
• Exhaust hood without fan for 6&10 1/1GN ovens	PNC 922733	<input type="checkbox"/>			
• Fixed tray rack, 8 GN 1/1, 85mm pitch	PNC 922741	<input type="checkbox"/>			
• Fixed tray rack, 8 GN 2/1, 85mm pitch	PNC 922742	<input type="checkbox"/>			
• 4 high adjustable feet for 6 & 10 GN ovens, 230-290mm	PNC 922745	<input type="checkbox"/>			
• Tray for traditional static cooking, H=100mm	PNC 922746	<input type="checkbox"/>			

**Front**

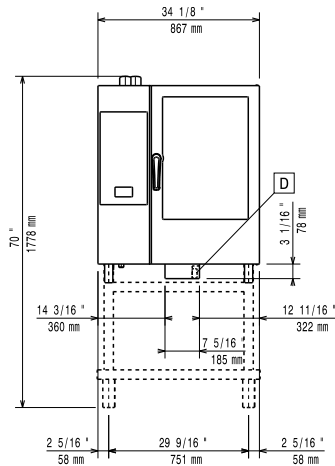

**Side**

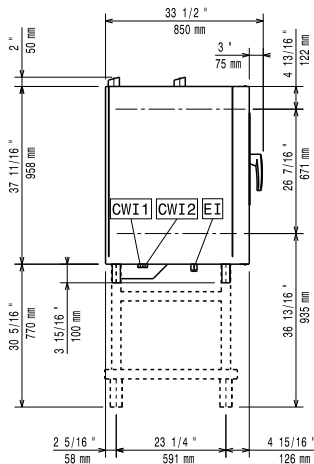

- C-** = Cold Water inlet 1      **EI** = Electrical inlet (power)
- WI-1**
- C-** = Cold Water Inlet 2
- WI-2**
- D** = Drain
- DO** = Overflow drain pipe

**Top**

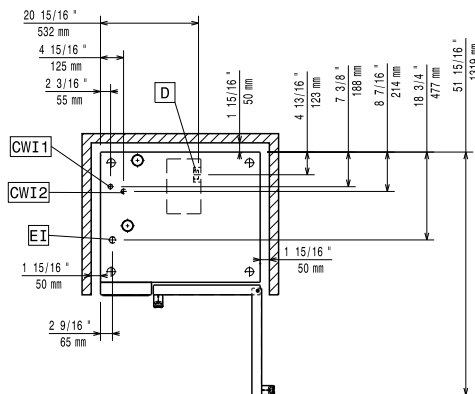

**Electric**

**Supply voltage:**

**218732 (ZCOE101T2S0)** 400-430 V/3N ph/50-60 Hz

**Electrical power, default:**

19 kW

**Electrical power max.:**

19.8 kW

**Circuit breaker required**

**Water:**

**Water inlet "FCW"**

**connection:** 3/4"

**Pressure, bar min/max:** 1-6 bar

**Drain "D":** 50mm

**Max inlet water supply**

**temperature:** 30 °C

**Chlorides:** <17 ppm

**Conductivity:** >50 µS/cm

*Electrolux Professional* recommends the use of treated water, based on testing of specific water conditions.

Please refer to user manual for detailed water quality information.

**Installation:**

Clearance: 5 cm rear and right hand sides.

**Clearance:**

**Suggested clearance for service access:**

50 cm left hand side.

**Capacity:**

**GN:** 10 - 1/1 Gastronorm

**Max load capacity:** 50 kg

**Key Information:**

**Door hinges:**

**External dimensions, Width:**

867 mm

**External dimensions, Depth:**

775 mm

**External dimensions, Height:**

1058 mm

**Net weight:**

148.5 kg

**Shipping weight:**

166.5 kg

**Shipping volume:**

1.06 m<sup>3</sup>