

Magistar Combi TI Natural Gas Combi Oven 6GN1/1

ITEM # _____

MODEL # _____

NAME # _____

SIS # _____

AIA # _____

INDUSTRY
KITCHENS

www.industrykitchens.com.au 1800 611 058



218670 (ZCOG61K2U0)

Magistar Combi TI combi boilerless oven with touch screen control, 6x1/1GN, gas, 2 cooking modes (recipe program, manual), automatic cleaning (Australia)

Short Form Specification

Item No.

- Combi oven with digital interface with guided selection.
- Built-in steam generator with real humidity control based upon Lambda Sensor.
 - AirFlow air distribution system to achieve maximum performance with 5 fan speed levels.
 - HP Automatic Cleaning: Automatic and built-in self cleaning system with integrated descale of the steam generator. 5 automatic cycles (soft, medium, strong, extra strong, rinse-only).
 - Cooking modes: Programs (a maximum of 100 recipes can be stored); Manual (steam, combi and convection cycles); EcoDelta cooking cycle; Regeneration cycle.
 - Automatic backup mode to avoid downtime.
 - USB port to download HACCP data, programs and settings. Connectivity ready.
 - Single sensor core temperature probe.
 - Double-glass door with LED lights.
 - Stainless steel construction throughout.
 - Supplied with n.1 tray rack 1/1 GN, 67 mm pitch.

Main Features

- High resolution full touch screen interface (translated in more than 30 languages) - color-blind friendly panel.
- Boilerless steaming function to add and retain moisture for high quality, consistent cooking results.
- Dry hot convection cycle (max 300 °C) ideal for low humidity cooking. Automatic moistener (11 settings) for boiler-less steam generation.
- EcoDelta cooking: cooking with food probe maintaining preset temperature difference between the core of the food and the cooking chamber.
- Programs mode: a maximum of 1000 recipes can be stored in the oven's memory, to recreate the exact same recipe at any time. The recipes can be group in 16 different categories to better organize the menu. 16-step cooking programs also available.
- MultiTimer function to manage up to 20 different cooking cycles at the same time, improving flexibility and ensuring excellent cooking results. Can be saved up to 200 MultiTimer programs.
- AirFlow air distribution system to achieve maximum performance in chilling/heating evenness and temperature control thanks to a special design of the chamber combined with high precision variable speed fan.
- Fan with 7 speed levels from 300 to 1500 RPM and reverse rotation for optimal evenness. Fan stops in less than 5 seconds when door is opened.
- Single sensor core temperature probe included.
- Pictures upload for full customization of cooking cycles.
- Automatic fast cool down and pre-heat function.
- Make-it-mine feature to allow full personalization or locking of the user interface.
- SoloMio lets the user group the favorite functions in the homepage for immediate access.
- Calendar works as an agenda where the user can plan the daily work and receive personalized alerts for each task.
- Grease Collector: predisposed for integrated grease drain and collection for safer operation (dedicated base as optional accessory).
- USB port to download HACCP data, share cooking programs and configurations. USB port also allows to plug-in sous-vide probe (optional accessory).
- Connectivity ready for real time access to connected appliances from remote and HACCP monitoring (requires optional accessory).
- Trainings and guidances supporting materials easily accessible by scanning QR-Code with any mobile device.
- Back-up mode with self-diagnosis is automatically activated if a failure occurs to avoid downtime.
- Automatic consumption visualization at the end of the cycle.
- 2 different chemical options available: solid and liquid (requires optional accessory).
- Capacity: 6 GN 1/1 trays.
- Connectivity ready for real time access to connected appliances from remote and data monitoring (requires

APPROVAL: _____

optional accessory – contact the Company for more details).

- [NOT TRANSLATED]

Construction

- Double thermo-glazed door with open frame construction, for cool outside door panel. Swing hinged easy-release inner glass on door for easy cleaning.
- Seamless hygienic internal chamber with all rounded corners for easy cleaning.
- 304 AISI stainless steel construction throughout.
- Front access to control board for easy service.
- IPX 5 spray water protection certification for easy cleaning.
- Supplied with n.1 tray rack 1/1 GN, 67 mm pitch.

Sustainability

- Reduced power function for customized slow cooking cycles.
- HP Automatic Cleaning: Automatic and built-in self cleaning system. 5 automatic cycles (soft, medium, strong, extra strong, rinse-only) and green functions to save energy, water, detergent and rinse aid. Also programmable with delayed start.
- Cooking Optimizer function organizes the cooking sequence of the chosen cycles optimizing the work in the kitchen from a time and energy efficiency point of view.

Optional Accessories

- Water softener with cartridge and flow meter (high steam usage) PNC 920003
- Water softener with salt for ovens with automatic regeneration of resin PNC 921305
- Wheel kit for 6 & 10 GN 1/1 and 2/1 GN oven base (not for the disassembled one) PNC 922003
- Pair of AISI 304 stainless steel grids, GN 1/1 PNC 922017
- Pair of grids for whole chicken (8 per grid - 1,2kg each), GN 1/1 PNC 922036
- AISI 304 stainless steel grid, GN 1/1 PNC 922062
- Grid for whole chicken (4 per grid - 1,2kg each), GN 1/2 PNC 922086
- External side spray unit (needs to be mounted outside and includes support to be mounted on the oven) PNC 922171
- Baking tray for 5 baguettes in perforated aluminum with silicon coating, 400x600x38mm PNC 922189
- Baking tray with 4 edges in perforated aluminum, 400x600x20mm PNC 922190
- Baking tray with 4 edges in aluminum, 400x600x20mm PNC 922191
- Pair of frying baskets PNC 922239
- AISI 304 stainless steel bakery/pastry grid 400x600mm PNC 922264
- Double-step door opening kit PNC 922265
- Grid for whole chicken (8 per grid - 1,2kg each), GN 1/1 PNC 922266
- USB probe for sous-vide cooking PNC 922281
- Grease collection tray, GN 1/1, H=100 mm PNC 922321
- Kit universal skewer rack and 4 long skewers for GN 1/1 ovens PNC 922324
- Universal skewer rack PNC 922326

- 4 long skewers PNC 922327
- Smoker for lengthwise and crosswise oven (4 kinds of smoker wood chips are available on request) PNC 922338
- Multipurpose hook PNC 922348
- 4 flanged feet for 6 & 10 GN , 2", 100-130mm PNC 922351
- Grid for whole duck (8 per grid - 1,8kg each), GN 1/1 PNC 922362
- Tray support for 6 & 10 GN 1/1 disassembled open base PNC 922382
- Wall mounted detergent tank holder PNC 922386
- USB SINGLE POINT PROBE PNC 922390
- Tray rack with wheels, 6 GN 1/1, 65mm pitch (included) PNC 922600
- Tray rack with wheels, 5 GN 1/1, 80mm pitch PNC 922606
- Bakery/pastry tray rack with wheels holding 400x600mm grids for 6 GN 1/1 oven and blast chiller freezer, 80mm pitch (5 runners) PNC 922607
- Slide-in rack with handle for 6 & 10 GN 1/1 oven PNC 922610
- Open base with tray support for 6 & 10 GN 1/1 oven PNC 922612
- Cupboard base with tray support for 6 & 10 GN 1/1 oven PNC 922614
- Hot cupboard base with tray support for 6 & 10 GN 1/1 oven holding GN 1/1 or 400x600mm PNC 922615
- External connection kit for detergent and rinse aid PNC 922618
- Grease collection kit for GN 1/1-2/1 cupboard base (trolley with 2 tanks, open/close device and drain) PNC 922619
- Stacking kit for gas 6 GN 1/1 oven placed on gas 6 GN 1/1 oven PNC 922622
- Stacking kit for gas 6 GN 1/1 oven placed on gas 10 GN 1/1 oven PNC 922623
- Trolley for slide-in rack for 6 & 10 GN 1/1 oven and blast chiller freezer PNC 922626
- Trolley for mobile rack for 2 stacked 6 GN 1/1 ovens on riser PNC 922628
- Trolley for mobile rack for 6 GN 1/1 on 6 or 10 GN 1/1 ovens PNC 922630
- Riser on feet for 2 6 GN 1/1 ovens or a 6 GN 1/1 oven on base PNC 922632
- Riser on wheels for stacked 2x6 GN 1/1 ovens, height 250mm PNC 922635
- Stainless steel drain kit for 6 & 10 GN oven, dia=50mm PNC 922636
- Plastic drain kit for 6 & 10 GN oven, dia=50mm PNC 922637
- Grease collection kit for open base (2 tanks, open/close device and drain) PNC 922639
- Wall support for 6 GN 1/1 oven PNC 922643
- Dehydration tray, GN 1/1, H=20mm PNC 922651
- Flat dehydration tray, GN 1/1 PNC 922652
- Open base for 6 & 10 GN 1/1 oven, disassembled PNC 922653
- Bakery/pastry rack kit for 6 GN 1/1 oven with 5 racks 400x600mm and 80mm pitch PNC 922655

- | | | | | | |
|--|------------|--------------------------|--|------------|--------------------------|
| • Stacking kit for gas 6 GN 1/1 oven placed on 7kg and 15kg crosswise blast chiller freezer | PNC 922657 | <input type="checkbox"/> | • Non-stick universal pan, GN 1/2, H=60mm | PNC 925011 | <input type="checkbox"/> |
| • Heat shield for stacked ovens 6 GN 1/1 on 6 GN 1/1 | PNC 922660 | <input type="checkbox"/> | • Compatibility kit for installation on previous base GN 1/1 | PNC 930217 | <input type="checkbox"/> |
| • Heat shield for stacked ovens 6 GN 1/1 on 10 GN 1/1 | PNC 922661 | <input type="checkbox"/> | | | |
| • Heat shield for 6 GN 1/1 oven | PNC 922662 | <input type="checkbox"/> | | | |
| • Kit to convert from natural gas to LPG | PNC 922670 | <input type="checkbox"/> | | | |
| • Kit to convert from LPG to natural gas | PNC 922671 | <input type="checkbox"/> | | | |
| • Flue condenser for gas oven | PNC 922678 | <input type="checkbox"/> | | | |
| • Fixed tray rack for 6 GN 1/1 and 400x600mm grids | PNC 922684 | <input type="checkbox"/> | | | |
| • Kit to fix oven to the wall | PNC 922687 | <input type="checkbox"/> | | | |
| • 4 high adjustable feet for 6 & 10 GN ovens, 100-115MM | PNC 922688 | <input type="checkbox"/> | | | |
| • Tray support for 6 & 10 GN 1/1 open base | PNC 922690 | <input type="checkbox"/> | | | |
| • Detergent tank holder for open base | PNC 922699 | <input type="checkbox"/> | | | |
| • Bakery/pastry runners 400x600mm for 6 & 10 GN 1/1 oven base | PNC 922702 | <input type="checkbox"/> | | | |
| • Wheels for stacked ovens | PNC 922704 | <input type="checkbox"/> | | | |
| • CHIMNEY ADAPTOR NEEDED IN CASE OF CONVERSION OF 6 GN 1/1 OR 6 GN 2/1 OVENS FROM NATURAL GAS TO LPG | PNC 922706 | <input type="checkbox"/> | | | |
| • Mesh grilling grid | PNC 922713 | <input type="checkbox"/> | | | |
| • Probe holder for liquids | PNC 922714 | <input type="checkbox"/> | | | |
| • Exhaust hood with fan for 6 & 10 GN 1/1 ovens | PNC 922728 | <input type="checkbox"/> | | | |
| • Exhaust hood without fan for 6&10 1/1GN ovens | PNC 922733 | <input type="checkbox"/> | | | |
| • Fixed tray rack, 5 GN 1/1, 85mm pitch | PNC 922740 | <input type="checkbox"/> | | | |
| • 4 high adjustable feet for 6 & 10 GN ovens, 230-290mm | PNC 922745 | <input type="checkbox"/> | | | |
| • Tray for traditional static cooking, H=100mm | PNC 922746 | <input type="checkbox"/> | | | |
| • Double-face griddle, one side ribbed and one side smooth, 400x600mm | PNC 922747 | <input type="checkbox"/> | | | |
| • TROLLEY FOR GREASE COLLECTION KIT | PNC 922752 | <input type="checkbox"/> | | | |
| • Water inlet pressure reducer | PNC 922773 | <input type="checkbox"/> | | | |
| • EXTENSION FOR CONDENSATION TUBE | PNC 922776 | <input type="checkbox"/> | | | |
| • Non-stick universal pan, GN 1/1, H=20mm | PNC 925000 | <input type="checkbox"/> | | | |
| • Non-stick universal pan, GN 1/ 1, H=40mm | PNC 925001 | <input type="checkbox"/> | | | |
| • Non-stick universal pan, GN 1/1, H=60mm | PNC 925002 | <input type="checkbox"/> | | | |
| • Double-face griddle, one side ribbed and one side smooth, GN 1/1 | PNC 925003 | <input type="checkbox"/> | | | |
| • Aluminum grill, GN 1/1 | PNC 925004 | <input type="checkbox"/> | | | |
| • Frying pan for 8 eggs, pancakes, hamburgers, GN 1/1 | PNC 925005 | <input type="checkbox"/> | | | |
| • Flat baking tray with 2 edges, GN 1/1 | PNC 925006 | <input type="checkbox"/> | | | |
| • Baking tray for 4 baguettes, GN 1/1 | PNC 925007 | <input type="checkbox"/> | | | |
| • Potato baker for 28 potatoes, GN 1/1 | PNC 925008 | <input type="checkbox"/> | | | |
| • Non-stick universal pan, GN 1/2, H=20mm | PNC 925009 | <input type="checkbox"/> | | | |
| • Non-stick universal pan, GN 1/2, H=40mm | PNC 925010 | <input type="checkbox"/> | | | |

Front

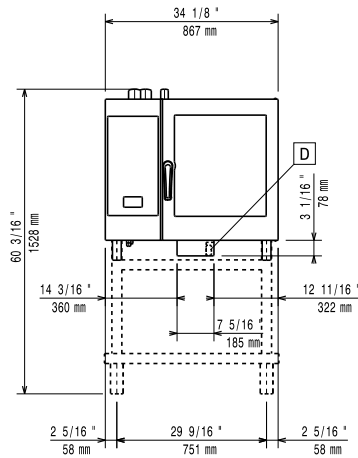

Side

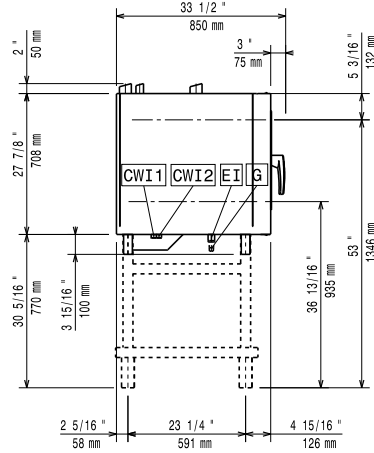

- C-WI-1** = Cold Water inlet 1
- C-WI-2** = Cold Water Inlet 2
- D** = Drain
- DO** = Overflow drain pipe
- EI** = Electrical inlet (power)
- G** = Gas connection

Top

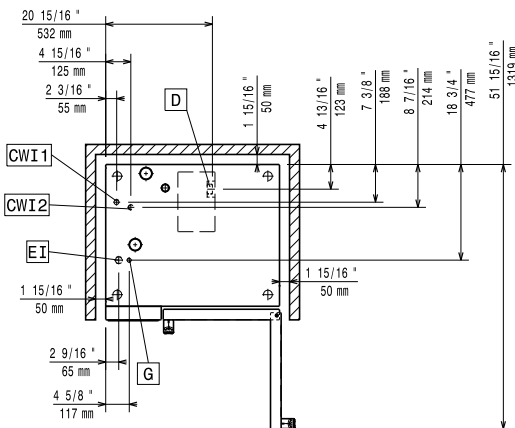

Electric

Supply voltage: 218670 (ZCOG61K2U0) 230-240 V/1 ph/50 Hz
Electrical power, default: 1.1 kW
Electrical power max.: 1.1 kW
Circuit breaker required

Gas

Gas Power: 13 kW
Standard gas delivery: Natural Gas G20
ISO 7/1 gas connection diameter: 1/2" MNPT

LPG:

Total thermal load: 44317 BTU (13 kW)

Water:

Water inlet "FCW" connection: 3/4"
Pressure, bar min/max: 1-6 bar
Drain "D": 50mm
Max inlet water supply temperature: 30 °C
Chlorides: <10 ppm
Conductivity: >50 µS/cm
Electrolux Professional recommends the use of treated water, based on testing of specific water conditions.
 Please refer to user manual for detailed water quality information.

Installation:

Clearance: Clearance: 5 cm rear and right hand sides.
Suggested clearance for service access: 50 cm left hand side.

Capacity:

GN: 6 - 1/1 Gastronorm
Max load capacity: 30 kg

Key Information:

Door hinges:
External dimensions, Width: 867 mm
External dimensions, Depth: 775 mm
External dimensions, Height: 808 mm
Net weight: 122.5 kg
Shipping weight: 139.5 kg
Shipping volume: 0.84 m³