

WD-6 DUPLUS DUPLUS ERGONOMIC PASSTHROUGH DISHWASHER

STANDARD FEATURES:

- Washes up to 50 baskets per hour
- Only 1 litre per cycle water consumption
- 45 litre wash tank volume
- Double final rinse with DUPLUS technology
- Unique hood designed for steam to escape at the back of machine
- Simple program selection – 3 levels of wash cycle for varying types of soiled product
- Auto Start function
- Electronic control panel with event log recording for improved diagnostics and rapid troubleshooting
- Automatic hood
- Automatic cleaning program
- Self-draining wash arms for optimum wash results
- 0.9kW wash pump with 9kW booster heater
- Includes drying agent/rinse aid injector
- Break tank with booster pump included
- Anti-clogging filter at front of machine
- Fixed basket conveyor designed for improved washing results and cleaning
- Smooth internal surfaces for easy cleaning
- Stainless steel construction
- Corner or in-line installation
- Supplied with 3 high quality dish racks for cups and plates
- Drain pump
- Detergent and rinse aid pumps for liquid detergent

Upgrades and options are available, please contact Moffat for more details

TECHNICAL INFORMATION:

Dimensions

Width: 600mm
Depth: 657mm
Height: 1430mm

Water

Water temperature: 5-70°C
Hot water connection: R1/2" Direct
Pressure: 20kPa
Flow: 10 litres per min
Water quality (Hardness): 2-7odH

Waste

Drain hose connection point

Electrical

3P+N+E 400-415V 50/60Hz
9.9kW 16A Cordset supplied

Refer operator manual for complete installation instructions

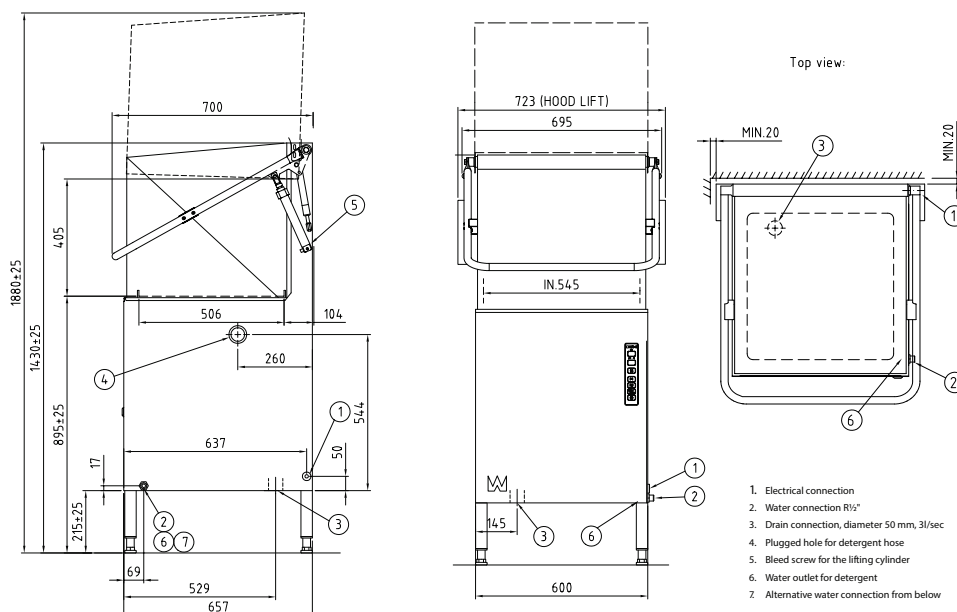

Australia

moffat.com.au

Moffat Pty Limited
740 Springvale Road
Mulgrave
Victoria 3170
Australia
Telephone +613-9518 3888
Facsimile +613-9518 3833
vsales@moffat.com.au

New Zealand

moffat.co.nz

Moffat Limited
45 Illinois Drive
Izone Business Hub
Rolleston 7675
New Zealand
Telephone +64 3-983 6600
Facsimile +64 3-983 6660
sales@moffat.co.nz

In line with policy to continually develop and improve its products, Moffat Limited reserves the right to change specifications and design without notice.