

Technical data sheet for

## GAS RANGE ELECTRIC STATIC OVEN 900mm

RN8610GE, RN8613GE, RN8616GE, RN8619GE



RN8610GE

- Heavy-duty construction
- 28 MJ/hr open burners
- Flame failure standard
- Pilot burners optional
- 300mm, 600mm, and 900mm griddle plate options
- Optional simmer plates
- GN 2/1 6.5kW electric static oven
- Drop down door
- Stainless steel exterior
- Easy clean
- Easy service
- Fully modular
- Low back models (RNL) available

### Overall Construction

- Galvanized steel chassis
- Welded hob with 1.5mm 304 stainless steel bull nose
- Splashback and hob sides 1.2mm 304 stainless steel
- Front panels and oven sides 0.9mm 304 stainless steel
- 150mm legs in 63mm dia. heavy-duty 1.2mm 304 stainless steel with adjustable feet

### COOKTOP

- Cast iron 28MJ/hr open burners with forged brass cap
- Vitreous enamelled cast iron potstands
- Vitreous enamelled open burner spill covers
- Cast iron simmer plates (optional extra)
- 12mm thick mild steel griddle plates
- 2.5mm 304 stainless steel griddle splash guards
- Vitreous enamelled spill trays
- Aluminised steel internal construction

Griddle sections are standard on RH side. Available on LH side or centre to order or by conversion.

### OVEN

- Fully welded and vitreous enamelled oven liner
- GN 2/1 capacity with 4 position racking
- Heavy-duty easy remove heavy wire chrome rack supports
- Cast iron even heat oven sole plate
- 6.5kW heating elements
- Welded frame drop down door with heavy-duty spring hinge system
- 0.9mm 304 stainless steel door outer
- 1.0mm press formed vitreous enamelled door inner
- 50mm high density fibreglass insulated
- Stay cool stainless steel door handle with cast metal handle mounts
- Supplied with two chrome wire oven racks

### Controls

- Large easy use control knob - heat resistant reinforced
- Easy view control settings on knob

### COOKTOP

- Variable high to low controls to open burners
- Open burners flame failure standard with pilot burners optional
- Variable high to low controls to griddles
- Griddles standard with pilot, flame failure and piezo ignition

### OVEN

- Separate temperature and top heat power regulation controls
- 50-320°C thermostatic control
- Lo-Hi top heat control
- Indicator lights for power and heating

### Cleaning and Servicing

- All models with easy clean stainless steel external finish
- Lift off burners heads and vitreous enamelled burner spill covers
- Vitreous enamelled spill trays under open burner and griddle sections
- Removable oven racking and sole plate
- Easy clean vitreous enamel oven and door inner
- Door hinge spring adjustable on unit (door outer removed)
- Door disengages for lift off removal and increased service access
- All parts front accessible from installed position
- Access to all parts from front of unit

Technical data sheet for

## GAS RANGE ELECTRIC STATIC OVEN 900mm

### Specifications

#### Burners

Open Burners 28MJ/hr dual flame ring with simmer rate  
Griddle Burners 20MJ/hr per 300mm section

#### Oven Elements

4.5kW bottom heat element  
2.0kW top heat element

#### Gas power

RN8610GE 168 MJ/hr, 46.6kW  
RN8613GE 132 MJ/hr, 36.6kW  
RN8616GE 96 MJ/hr, 26.6kW  
RN8619GE 60 MJ/hr, 16.6kW

#### Electrical requirements

6.5kW

#### 1 phase connection:

230-240Vac, 50/60Hz, 1P+N+E, 27A

#### 3 phase connection:

400-415Vac, 50/60Hz, 3P+N+E

L1 9.4A

L2 9.4A

L3 8.3A

#### Griddle Plate

300mm Griddle cooking surface  
292mm x 475mm, 1387cm<sup>2</sup>  
600mm Griddle cooking surface  
592mm x 475mm, 2812cm<sup>2</sup>  
900mm Griddle cooking surface  
892mm x 475mm, 4237cm<sup>2</sup>

#### Oven Dimensions

Width 665mm  
Depth 590mm  
Height 385mm  
Rack size 660mm x 540mm  
Rack positions 4

#### Gas connection

R 3/4 (BSP) male  
130mm from RH side, 32mm from rear, and 655mm from floor

All units supplied with Natural and LP gas regulator

#### Electrical connection

23mm from RH side, 484mm from rear, and 150mm from floor

#### DIMENSIONS

Width 900mm  
Depth 805mm  
Height 915mm  
Incl. splashback 1130mm  
Incl. low back 970mm

#### NETT WEIGHT

220kg

#### PACKING DATA

1.03m<sup>3</sup>, 285kg  
Width 945mm  
Depth 870mm  
Height 1255mm

#### GAS TYPES

Available in Natural gas and LP gas  
Please specify when ordering  
Units supplied complete with gas type conversion kits  
Other gas types on request

#### OPTIONS AT EXTRA COST

Simmer plates (replaces Potstand)  
Ribbed griddle plates  
Joining caps  
Castors  
Plinth mounting

RN8610GE, RN8613GE, RN8616GE, RN8619GE

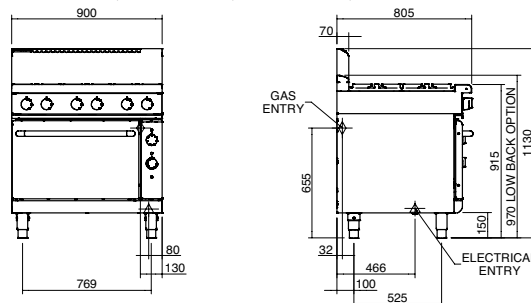

moffat.com.au  
moffat.co.nz

Australia  
moffat.com.au

#### Moffat Pty Limited

Victoria/Tasmania  
740 Springvale Road  
Mulgrave, Victoria 3170  
Telephone +613-9518 3888  
Facsimile +613-9518 3833  
vsales@moffat.com.au

New South Wales  
Telephone +612-8833 4111  
nswsales@moffat.com.au

South Australia  
Telephone +613-9518 3888  
vsales@moffat.com.au

Queensland  
Telephone +617-3630 8600  
qldsales@moffat.com.au

Western Australia  
Telephone +618-9413 2400  
wasales@moffat.com.au

#### New Zealand

moffat.co.nz

#### Moffat Limited

Rolleston  
45 Illinois Drive  
Izone Business Hub  
Rolleston 7675  
Telephone +64 3-983 6600  
Facsimile +64 3-983 6660  
sales@moffat.co.nz

Auckland  
Telephone +64 9-574 3150  
sales@moffat.co.nz



ISO9001  
Quality  
Management  
Standard



Cert. No. 6892

In line with policy to continually develop and improve its products, Moffat Limited reserves the right to change specifications and design without notice.

© Copyright Moffat Ltd  
AN.W8.08/19