

Classe 5 USB Tall - RC1G C5EVO BLK

RANCILIO CLASSE 5 USB TALL 1 GROUP

INDUSTRY KITCHENS

www.industrykitchens.com.au 1800 611 058



STANDARD FEATURES

- Tall deck accommodates tall cups up to 145mm in height includes step for espresso cups
- Single hot water tap with manual operation for full control
- Ergonomic portafilter holder up to 21g capacity, comfortable for all-day operation
- C-Lever – quarter turn steam tap features two positions: purge (down) or fully open (up)
- Hydro hub – integrated manifold for precise water delivery and distribution
- Multifunction onboard computer and USB port for simple programming and data transfer
- Water pump pressure control gauge that keeps you in control
- Built-in volumetric rotary vane water pump for simple and safe installation
- Steam boiler pressure control with mechanical pressure stat
- Automated cleaning programme simplifies your daily clean

OVERALL CONSTRUCTION

- Hand rolled copper steam boiler - 4 litre capacity
- Brushed stainless steel front and rear panels
- Anthracite black ABS nylon side panels
- Adjustable feet with optional extensions
- Backflow valve on the boiler and steam tap

CONTROLS

- Soft-touch keypads with 4 programmable drink dosing pre-sets for easy espresso preparation
- White LED backlights easy to read keypad buttons
- One manual steam wand for frothing and steaming milk

CLEANING AND MAINTENANCE

- Stainless steel drip tray - dishwasher safe
- Easy Clean manages the cleaning process of group heads to perform automatically
- Genuine cleaning products sold separately

INCLUDES

- 1 x Single group handle
- 1 x Single filter basket – 16g
- 1 x Double group handle
- 1 x Double filter basket – 21g
- 1 x Rubber blind filter disc
- 1 x Group head cleaning brush
- User manual / Warranty card

MATCHING PRODUCTS



CLASSE 5 USB
TALL 2 GROUP COMPACT



CLASSE 5 USB
TALL 2 GROUP



CLASSE 5 USB
TALL 3 GROUP



CLASSE 7 USB
TALL 2 GROUP



CLASSE 7 USB
TALL 2 GROUP iSTEAM



CLASSE 7 USB
TALL 3 GROUP



KYRO EVO

Classe 5 USB Tall - RC1G C5EVO BLK

RANCILIO CLASSE 5 USB TALL 1 GROUP

TECHNICAL INFORMATION

Dimensions

Width:	410mm
Depth:	539mm
Height:	519mm
Nett weight:	37kg
Boiler Capacity:	4 litres

ELECTRICAL

Power requirements: 240V, 1P+N+E,
50/60Hz, 10A cordset fitted
Boiler Power: 2.05kW



WATER CONNECTIONS AND DRAINS

- 40mm PVC drain and waste trap - 300mm upstand
- Fixed water supply connection
- Mains cold water 3/8" BSP male thread connection
- Flow pressure: 200kPa -500kPa, min 4L/min

RANCILIO WATER SPECIFICATION

Optimum Parameter	Measurement Range
	Never more than 50 PPM more than to Total Hardness
TDS <135	
Carbonate Hardness 50 ppm	40-90 ppm
Total Hardness 85 ppm	50-100 ppm
pH (ideal) 7	6.5 – 8.5
Chlorides Cl -	< 30 ppm

INSTALLATION CLEARANCE

- Allow 152.4mm / 6" clearance on all sides of the machine.
- Allow 609mm x 127mm / 24" x 5" for in-line filter. Filter can be mounted behind the machine or under the counter.
- Allow a minimum of 3" (762 mm) clear space under filter to facilitate filter change.
- All services to be within 1m of machine placement
- Always refer to installation manual



Australia

www.moffat.com.au

New Zealand

www.moffat.co.nz

Australia

Moffat Pty Limited

Victoria/Tasmania
740 Springvale Road
Mulgrave, Victoria 3170
Telephone +61 3-9518 3888
Facsimile +61 3-9518 3833
vsales@moffat.com.au

New South Wales

Telephone +61 2-8833 4111
nswsales@moffat.com.au

South Australia

Telephone +61 3-9518 3888
vsales@moffat.com.au

Queensland

Telephone +61 7-3630 8600
qldsales@moffat.com.au

Western Australia

Telephone +61 8-9413 2400
wasales@moffat.com.au

New Zealand

Moffat Limited

Christchurch
45 Illinois Drive
Izone Business Hub
Rolleston 7675
Telephone +64 3-983 6600
Facsimile +64 3-983 6660
sales@moffat.co.nz

Auckland

Telephone +64 9-574 3150
sales@moffat.co.nz



In line with policy to continually develop and improve its products, Moffat Limited reserves the right to change specifications and design without notice.

© Copyright Moffat Ltd
AN.RAN.2301

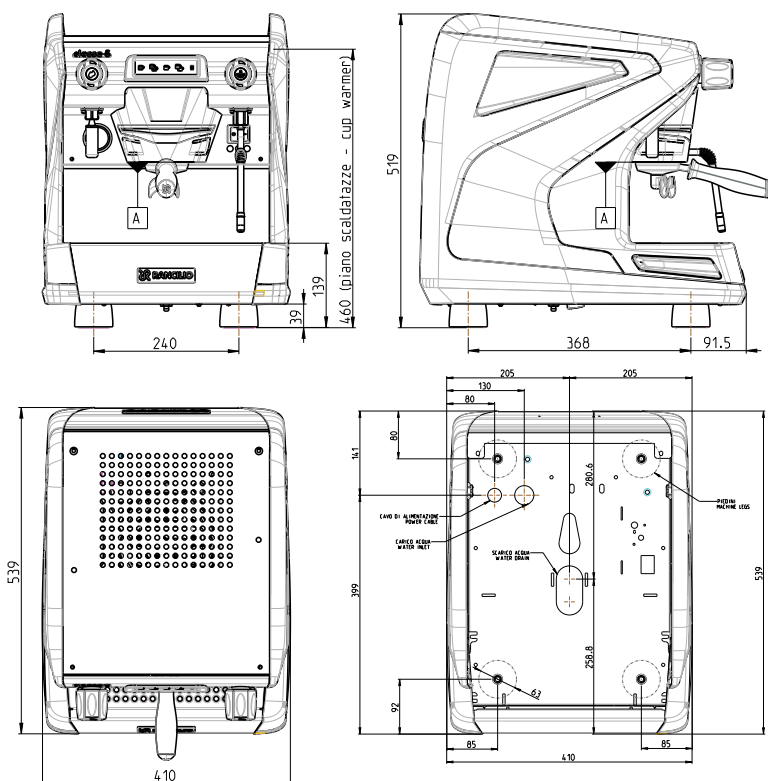

an Ali Group Company



The Spirit of Excellence