

MX1STS7-C Roll-in Blast Chiller only

Remote condensing unit version

Standard Features

- Free standing – roll in trolley unit
- 7" ergonomic touch screen with large keys for ease of use
- User friendly operation with easy to use functions:
 - Hard or soft chill mode
 - Easy switch to probe or timer mode
 - Self Adaptive intelligent chilling mode
- Auxiliary functions: ice cream hardening, ventilated drying, multiple timers, customisable multiple phases, raw fish sanitation
- 40 program cycles with favourites key – shortcuts to last 9 programs used
- Pre-chilling cycle key to maximise efficiency
- Automatic hold mode after each cycle
- Manual defrosting with automatic control of time
- 3 point core temperature probe
- Timer mode or continuous run
- Integrated door latch to aerate cabinet when not in use
- Automatic fan stop when opening the door
- USB connection
- External and internal finish made of 304 stainless steel
- Supplied with 20mm insulated stainless steel floor and ramp
- Heated door frame to reduce condensation
- Injected polyurethane foam insulation - 80mm thick
- Supplied assembled

Please refer to Moffat price list for options and accessories

Technical data

Capacity	1 x 1/1GN trolley (trolley not included)
External dimensions	W 980mm x D 1030mm x H 2170mm
Usable internal dimensions	W 760mm x D 620mm x H 1885mm
Load capacity	80kg*
Electrical connections	1P+N+E, 230-240V, 50/60Hz, 20A, 2.7kW
Waste	Provide for a water runoff & trap to the selected waste point (B)
Door configuration	Must be stated at time of order
Nett weight	200kg
Remote condensing unit version (remote condensing unit not included)	
Remote condensing unit requirements - Refrigerant type R452A	
Condensing capacity upright Blast Chiller 3.3kW / 5.6kW / 8.1kW for the respective evaporation temperatures of -20/-10/0°C	
Remote condensing unit with pump down control	
Ambient temperature requirement +15°C — +43°C	

* Note – Load capacities may vary depending on the thermal conductivity of the food being chilled, the thickness of product and container used

Australia
moffat.com.au

New Zealand
moffat.co.nz

Moffat Pty Limited
740 Springvale Road
Mulgrave
Victoria 3170
Australia
Telephone +613-9518 3888
Facsimile +613-9518 3833
vsales@moffat.com.au

Moffat Limited
45 Illinois Drive
Izone Business Hub
Rolleston 7675
New Zealand
Telephone +64 3-983 6600
Facsimile +64 3-983 6660
sales@moffat.co.nz



Dimensions

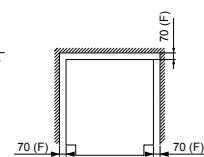
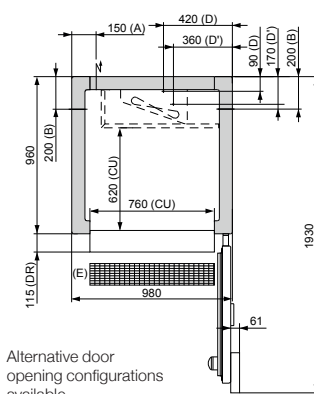
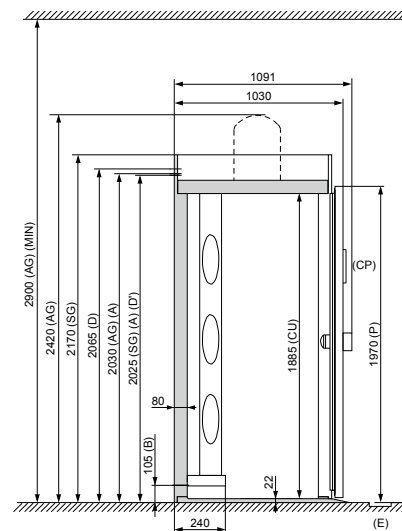

- (A) Electrical power supply
- (B) Pre-drilling for de-icing water runoff
- (AG) With air-cooled housed unit
- (MIN) Minimum headroom
- (SG) Without housed unit
- (D) Liquid Line 3/8"
- (D') Suction line 1 1/8"
- (CP) Control panel
- (E) Duct
- (F) Distance from wall
- (CU) Useful
- (P) Door height compared with the floor
- (DR) Ramp proud
- (SG) Overall height

Alternative door opening configurations available

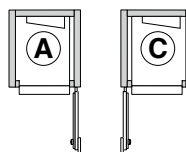

Disclaimer: All unit capacities are based on subjective testing. Moffat accepts no liability for production values. In line with policy to continually develop and improve its products, Moffat Limited reserves the right to change specifications and design without notice.

© Copyright Moffat Ltd
AN-FRI-S-2101

