

GAS COOKTOPS 600mm

G514D-B, G514D-CB, G514D-LS, G514C-B, G514C-CB, G514C-LS, G514B-B, G514B-CB, G514B-LS

- Heavy-duty construction
- 28 MJ/hr open burners
- Flame failure standard
- Pilot burners optional
- 300mm griddle plate options
- Optional simmer plates
- 3 models of base unit
- Rear rollers
- Stainless steel exterior
- Easy clean
- Easy service
- Fully modular



G514D-LS

Overall Construction

Cooktop

- Welded hob with 1.5mm 304 stainless steel bull nose
- Side panels 1.2mm 304 stainless steel
- Splashback 1.2mm 304 stainless steel
- Vitreous enamelled control panel
- Aluminised steel internal construction
- Cast iron 28MJ/hr open burners with forged brass cap
- Vitreous enamelled cast iron potstands
- Vitreous enamelled open burner spill covers
- Cast iron simmer plates (optional extra)
- 12mm thick mild steel griddle plate
- 2.5mm 304 stainless steel griddle splash guards
- Stainless steel spill trays

Griddle sections are standard on RH side. Available on LH side to order or by conversion.

Bench mount (supplied as -B model)

- Four 63mm dia. heavy-duty 1.2mm 304 stainless steel bench legs with adjustable feet
- Adjustable height 80mm – 105mm

Cabinet base (supplied as -CB model)

- Fully modular for match suite finish
- Double skin 0.9mm 304 stainless steel interior and exterior
- Optional GN 1/1 4 position racking kit
- 63mm dia. heavy-duty 1.2mm 304 stainless steel legs with two adjustable feet at front and two rollers at rear

Leg stand (supplied as -LS model)

- Fully modular for matched suite finish
- Framed top for connection to Cooktop

- 63mm dia. heavy-duty 1.2mm 304 stainless steel legs with two adjustable feet at front and two rollers at rear
- Fully modular framed stand shelf with 0.9mm 304 stainless steel finish
- Suitable for rear or through shelf gas connection to Cooktop
- Quick assembly design

Controls

- Variable high to low controls to open burners
- Open burners flame failure standard with pilot burners optional
- Variable high to low controls to griddles
- Griddles standard with pilot, flame failure and piezo ignition
- Large easy use control knob - heat resistant reinforced
- Easy view control settings on knob

Cleaning and Servicing

- All models with easy clean stainless steel external finish
- Lift off burner heads and vitreous enamelled burner spill covers
- Stainless steel spill trays under open burner and griddle sections
- Access to all parts from front of unit

GAS COOKTOPS 600mm

G514D-B, G514D-CB, G514D-LS, G514C-B, G514C-CB, G514C-LS, G514B-B, G514B-CB, G514B-LS

Specifications

Burners

Open Burners 28MJ/hr dual flame ring with simmer rate

Griddle Burners 20MJ/hr

Gas power

G514D 112 MJ/hr, 31kW

G514C 76 MJ/hr, 21kW

G514B 40 MJ/hr, 11kW

Griddle Plate

300mm Griddle cooking surface

292mm x 475mm, 1387cm²

600mm Griddle cooking surface

592mm x 475mm, 2812cm²

Gas connection

R 3/4 (BSP) male

All units supplied with Natural and LP gas regulator

Dimensions

Bench models

Width 600mm

Depth 812mm

Height 315mm

Incl. splashback 485mm

All models (excluding Bench model)

Width 600mm

Depth 812mm

Height 915mm

Incl. splashback 1085mm

Nett weight

Bench and Leg Stand models

80kg

Cabinet Base models

80kg

Packing data

Bench and Leg Stand models

0.37m³, 116kg

Width 645mm

Depth 870mm

Height 665mm

Cabinet Base models

0.70m³, 116kg

Width 645mm

Depth 870mm

Height 1255mm

Gas types

Available in Natural gas and LP gas, please specify when ordering

Units supplied complete with gas type conversion kits

Other gas types on request

Options

Adjustable feet at rear

Simmer plates (replaces Potstand)

Ribbed griddle plates

Joining caps

Castors

G514-B

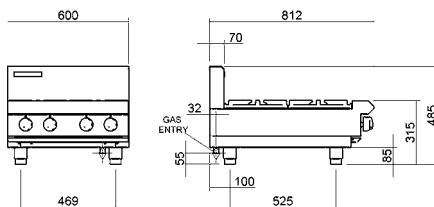

G514-LS

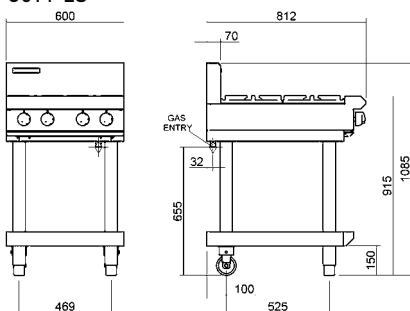

G514-CB

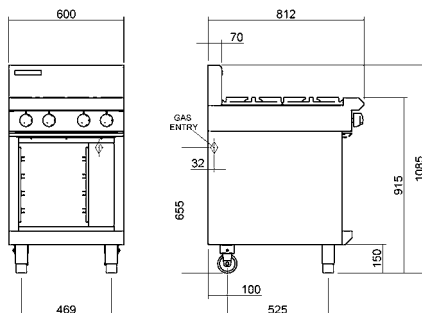

PLAN

G514D

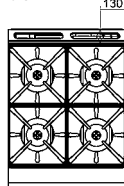

G514C

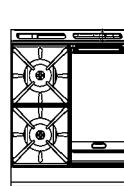

G514B

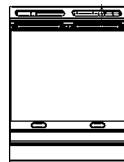

moffat.com.au

moffat.co.nz

Australia

moffat.com.au

Moffat Pty Limited

Victoria/Tasmania
740 Springvale Road
Mulgrave, Victoria 3170
Telephone +613-9518 3888
Facsimile +613-9518 3833
vsales@moffat.com.au

New South Wales
Telephone +612-8833 4111
nswsales@moffat.com.au

South Australia
Telephone +613-9518 3888
vsales@moffat.com.au

Queensland
Telephone +617-3630 8600
qldsales@moffat.com.au

Western Australia
Telephone +618-9413 2400
wasales@moffat.com.au

New Zealand

moffat.co.nz

Moffat Limited

Rolleston
45 Illinois Drive
Izone Business Hub
Rolleston 7675
Telephone +64 3-983 6600
Facsimile +64 3-983 6660
sales@moffat.co.nz

Auckland
Telephone +64 9-574 3150
sales@moffat.co.nz

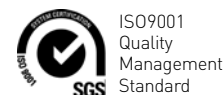

Cert. No. 6902

In line with policy to continually develop and improve its products, Moffat Limited reserves the right to change specifications and design without notice.

© Copyright Moffat Ltd
AN.BSE.01.19/1620